



Stock Lifters



Order no: 2.5502.00.1004.01000

2 · 19481 · 2004 · 1

09/2004



Order no	Stroke	l min.	l
2478.10.xxxxx*.025	25	121	146
050	50	146	196
080	80	176	256
100	100	196	296
125	125	224	349
150	150	246	396

* spring strengths available as standard:
50, 100, 150, 200, 250 and 320 daN.
Other spring strengths available to order.

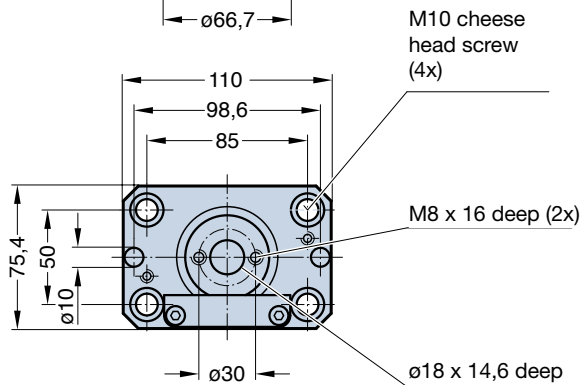
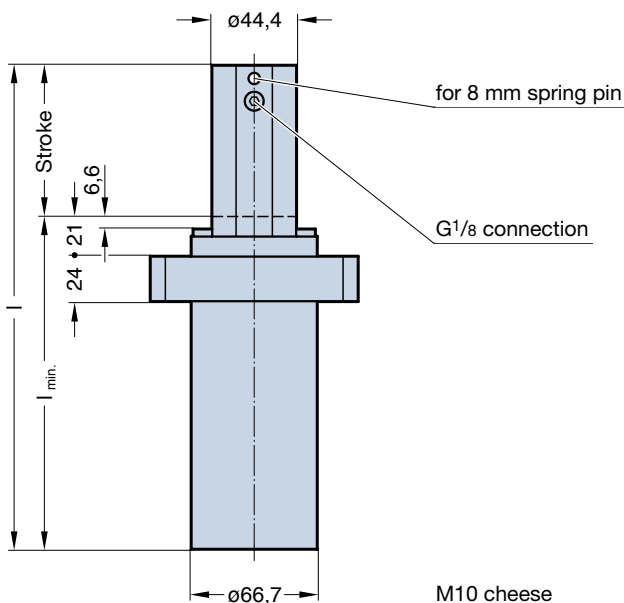

Installation example:

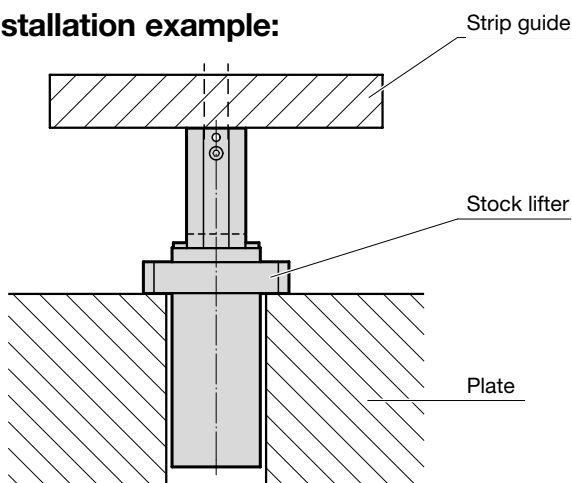

FIBRO Stock Lifters

- saves space and costs
- no additional guide or anti-rotation element required
- unaffected by side loads and dirt
- internal stop
- variable initial force setting from 45 daN to 320 daN
- direct mounting component lifter
- maintenance interval 2,000,000 strokes

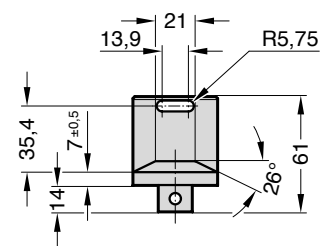

optional fixing adapter
2478.10.00320.01 enables side
fixing

Technical Informations:

- Pressure medium: Nitrogen N₂
- max. filling pressure: 180 bar
- min. filling pressure: 25 bar
- Working temperature: 0°C to +80°C
- Temperature related force increase: +/-0,3% / °C
- Strokes / minute: ca. 80 - 100
- Piston speed: max. 0,8 m/s
- Spare parts kit: 2478.10.00320

