

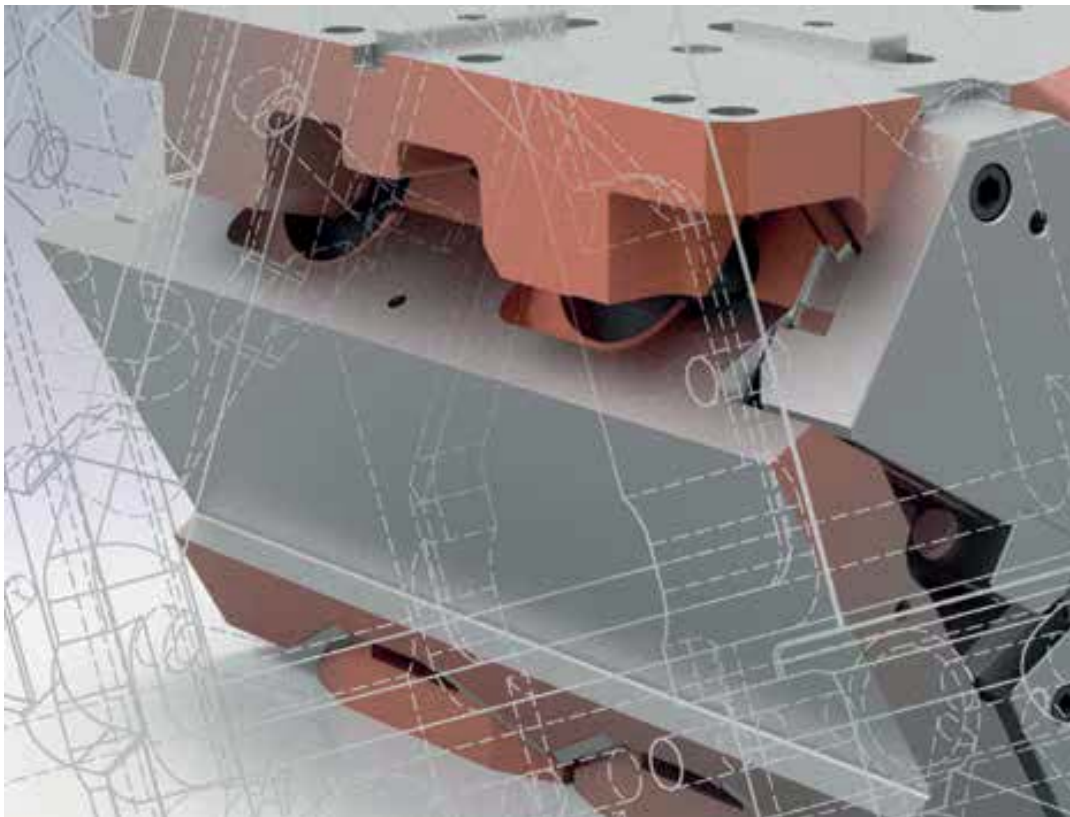

CAM UNITS



INTRODUCTION AND TABLE OF CONTENTS

ENGINEERING

2016.24. AERIAL CAM FCC BAK

DAIMLER, VOLVO,
VOLKSWAGEN GROUP

2016.25. AERIAL CAM FCC BAK

DAIMLER, VOLVO,
VOLKSWAGEN GROUP

2016.207. AERIAL CAM ECO LINE

2016.208. AERIAL CAM ECO LINE

CUSTOMER-SPECIFIC SERVICES

APPENDIX

EMERGENCY SITUATION / CONTACTS

FIBRO STANDARD PARTS YOUR PRODUCTION PARTNER

As a leading provider for Standard Parts for the tool & die industry, FIBRO offers a unique range of high precision products. With over a million different items, of which 40,000 are constantly in stock and available at short notice, FIBRO Standard Parts is a guaranteed one-stop shop for tool manufacturers around the world.

FIBRO exceeds our customers high quality expectations by following the most robust manufacturing processes ensuring that the tight tolerance and accuracy requirements of our products are delivered.

The wide range of services we offer gives you multiple ways to access support from us: for example in direct contact via support with the appropriate product selection and design, by delivering all the necessary CAD data and seamless workflows in dispatch.

Profit from the combination of companies operating on the international stage, and specialist firms rooted in their specific regions.



around 600
employees worldwide



production plants in
Germany, Italy, India
and China



45 agencies around
the world



a quality management system
in line with DIN EN ISO 9001



FIBRO branch offices in
France, Poland, the USA,
India, Singapore and Korea



an environmental
management system in line
with DIN EN ISO 14001

INNOVATION FROM TRADITION

The Standard Parts Division operates from the facilities in Hassmersheim, India, and China. Here, a large range of standard parts are manufactured, stored, and shipped to customers worldwide.

The product range is tailored to customers in the tool, mold, machine, and system engineering industries.

They include steel die sets, guide elements, oilless guide elements and precision components such as punches and matrixes, special steel compression springs, gas springs, forming materials, metal bonding agents, moulding resins, peripheral equipment for pressing and tool making, tool slides with cam or roller slides and hydraulic cam systems.

VERTRETUNGEN · REPRESENTATIVES · REPRESENTATIONS · RAPPRESENTANTES ·

DEUTSCHLAND

Außendienst Andreas Otto

Immenweg 3
16356 Ahrensfelde OT Eiche
T +49 30 423 97 15
M +49 170 739 00 64
a.otto@fibro.de

PLZ 10000-19000

Walter Ruff GmbH

Heerenholz 9 28307 · Bremen
T +49 421 438 78-0
F +49 421 438 78-22
mail@praeziruff.de · www.praeziruff.de

PLZ 20000-29000, 49000

Außendienst Stephan Hoffmann

Unter den Linden 22
38667 Bad Harzburg
M +49 171 971 90 05
s.hoffmann@fibro.de

PLZ 30000-31000, 37000-39000

Außendienst Daniel Kolakowski

Auf der Strotheide 50 · 32051 Herford
M +49 170 576 00 09
d.kolakowski@fibro.de

PLZ 32000-34000, 48000-49000

Außendienst Ralf Feldmann

Wiesenstraße 23b · 58339 Breckerfeld
M +49 151 12 59 01 59
r.feldmann@fibro.de

**PLZ 35000-36000, 57000, 60000-61000,
65000**

Außendienst Lars Jahncke

Locher Straße 44 · 42719 Solingen
T +49 212 25 43-462 · F -390
M +49 170 7637125
l.jahncke@fibro.de

PLZ 42000, 44000-46000, 58000-59000

Außendienst Hartwig Hennemann

Staubenthaler Höhe 79
42369 Wuppertal
T +49 202 283 17 56
F +49 202 759 55 80
M +49 175 29 659 30
h.hennemann@fibro.de

PLZ 40000-42000, 47000, 50000-53000,

Außendienst Oliver Koop

Burgstraße 14
66780 Rehlingen-Siersburg
T +49 6835 923 28 10
F +49 6835 608 59 09
M +49 175 438 53 81
o.koop@fibro.de

PLZ 54000-56000, 66000

Außendienst Markus Rössl

Johann-Strauß-Straße 16/1
74906 Bad Rappenau
T +49 7264 20 64-17 · F -18
M +49 160 97 25 23 93
m.roessl@fibro.de

**PLZ 63000-64000, 67000-69000,
76000-77000**

Außendienst Manfred Wagner

Breslauer Straße 57 · 74372 Sersheim
T +49 7042 3-50 86 · F -748 20
M +49 170 563 52 30
m.wagner@fibro.de

PLZ 70000-73000, 88000-89000

Außendienst Matthias Ehrenfried

Steigerwaldstraße 25
74172 Neckarsulm
T +49 7132 34 56 90
F +49 7132 98 94 82
M +49 171 864 95 52
m.ehrenfried@fibro.de

PLZ 71000, 74000-75000, 97000

Außendienst Matthias Jörg

In der Krautbündt 44
77656 Offenburg-Zunsweile
M +49 151 21 28 25 00
m.joerg@fibro.de

PLZ 72000, 77000-79000, 88000

Jugard + Künstler GmbH

Landsberger Straße 289
80687 München
T +49 89 546 15 60
F +49 89 580 27 96
muc@jugard-kuenstner.de
www.jugard-kuenstner.de

PLZ 80000-89000

Jugard + Künstler GmbH

Weidentalstraße 45
90518 Altdorf bei Nürnberg
T +49 9187 936 69-0
F +49 9187 936 69-90
nbg@jugard-kuenstner.de
www.jugard-kuenstner.de

PLZ 90000-97000

HELD Werkzeugmaschinen Präzisionswerkzeuge GmbH

Fasaneninsel 1 · 07548 Gera
T +49 365 824 91 0
F +49 365 824 91 11
info@held-wzm.de
www.held-wzm.de

PLZ 01000-09000, 98000-99000

REPRESENTACIONES · PRZEDSTAWICIELSTWA · ZASTOUPENÍ · MÜMESSILLER · 代表处

INTERNATIONAL

AR ARCINCO Industrial Ltda.

Rua Oneda, 935 - Planalto
CEP 09895-280 - São Bernardo do Campo
- SP
T +55-11-3463.8855
F +55-11-4390.9155
arcinco@arcinco.com.br
www.arcinco.com.br

AT Rath & Co. Ges. m.b.H.

Teiritzstrasse 3 · 2100 Korneuburg
T +43 2262 608 0 · F +43 2262 608 60
office@rath-co.at · www.rath-co.at

AU Bruderer Presses Australia Pty. Ltd.

92 Trafalgar Street
Annandale, NSW 2038
T +61 419 400 995
F +61 296 864 809
Brudsyd@tpgi.com.au

BA Oro-Tech trgovina d.o.o.

Ulica borcev 1/b · SI-2000 Maribor
T +386 2 426 08 43
F +386 2 426 08 44
oro-tech.trgovina@siol.net

BE Schiltz s.a.

Rue Nestor Martin 315 · 1082 Bruxelles
T +32 2 464 4830 · F +32 2 464 4839
info@schiltz.be · www.schiltz-norms.be

BG Bavaria 2002 EOOD

Patriarh Evtimii 10
5100 Gorna Orjachoviza
T +359 618 64158 · F +359 618 64960
bavaria2002@gorna.net
www.bavaria2002.hit.bg

BR ARCINCO Industrial Ltda.

Rua Oneda, 935 - Planalto
CEP 09895-280 - São Bernardo do Campo
- SP
T +55-11-3463.8855
F +55-11-4390.9155
arcinco@arcinco.com.br
www.arcinco.com.br

CA FIBRO Inc.

139 Harrison Ave. · Rockford, IL 61104
T +1 815 229 1300
F +1 815 229 1303
info@fibroinc.com · www.fibro.com

CH FIBRO GmbH · 74855 Hassmersheim

Angebote: ac5.normalien@fibro.de
T +49 6266 73 439
F +49 6266 9205 670
Bestellungen: vc5.normalien@fibro.de
T +49 6266 73 468
F +49 6266 9205 671

CL Bermat S.A.

Coyancura 2283, Of. 601
Casilla 9781 · Santiago
T +56 2 231 88 77 · F +56 2 231 42 94
bermat@bermat.cl · www.bermat.cl

CN FIBRO (Shanghai)

Precision Products Co., Ltd.

1st Floor, Building 3, No. 253, Ai Du Road
Pilot Free Trade Zone, Shanghai 200131
T +86 21 6083 1596
F +86 21 6083 1599
info@fibro.cn · www.fibro.com

Jilin Province Feibo Tooling

Standard Parts Co., Ltd.

Add: Room303, No. 5470, Xi'an Avenue,
Luyuan District, Changchun City,
Jilin Province
T +86 431 8120 3792
F +86 431 8120 3792
feibomuju@sina.cn · www.fibro.com

Shenzhen Poleda Investment Co.,Ltd.

Add: 4/F, SED Technology Tower,
No.1 Keji Road, Hi-tech Industrial Park,
Nanshan District, Shenzhen
T +86 755 2398 5026/2398 5029
F +86 755 2398 5596
anson@poleda.cn · www.fibro.com

CY Militos Trading Ltd.

P.O.B. 27297 · 1643 Nicosia
T +357 22 75 12 56
F +357 22 75 22 11
militos@cytanet.com.cy

CZ Gore, s.r.o.

Košínova 3090/29a
61200 Brno - Kralovo Pole
T +42 541 219 607
F +42 541 219 606
obchod@gore.cz · www.gore.cz

DK EBI A/S

Naverland 29 St. Th · 2600 Glostrup
T +45 4497 8111 · F +45 4468 0626
ebi@ebi.dk · www.ebi.dk

DZ Pneumacoupe Blida Boufarik

86 Bld. Menad Mohamed
Boufarik, 09400 Blida
T +213 347 5655 · F +213 347 5655
pneumacoupe@yahoo.fr

EE CLE Baltic Oü

Sära street 10 · Peetri village
Rae county · 75312 Estonia
T +372 780 3530 · F +372 668 8679
roland.rebane@clegroup.com ·
www.clebaltic.com

EG Smeco

68, Abdel Rahman El Raffei St.
11351-Heliopolis West, Cairo
T +20 2 620 06 71 · F +20 2 620 06 74
r.metwally@tedata.net.eg

ES Daunert Máquinas-Herramientas, S. A.

c/. Tirso de Molina s/n Esquina
c/. Albert Einstein
Polígono Industrial Almeda
08940 Cornellá de Llobregat · Barcelona
T +34 93 475 1480
F +34 93 377 6464
info@daunert.com · www.daunert.com

FI CLE

Trollbergintie 10 · 10650 Tammisaari
T +358 2075 19-600
F +358 2075 19-619
info@cle.fi · www.cle.fi

VERTRETUNGEN · REPRESENTATIVES · REPRESENTATIONS · RAPPRESENTANTES ·

INTERNATIONAL

FR FIBRO France Sarl

26, avenue de l'Europe
67300 Schiltigheim
T +33 3 90 20 40 40
F +33 3 88 81 08 29
info@fibro.fr · www.fibro.com

GB Bruderer UK Ltd.

Unit H, Cradock Road
Luton · Bedfordshire LU4 0JF
T +44 1582 563 400
F +44 1582 493 993
mail@bruderer.co.uk
www.bruderer-presses.com

GR Konstantinos Koutseris & Co. - MEK

Pyloy 100 · 10441 Athen
T +30 210 5220557
F +30 210 5221208
info@mek.com.gr · www.mek.com.gr

HK FIBRO (Shanghai)

Precision Products Co., Ltd.

1st Floor, Building 3, No. 253, Ai Du Road
Pilot Free Trade Zone, Shanghai 200131
T +86 21 6083 1596
F +86 21 6083 1599
info@fibro.cn · www.fibro.com

HR WML Robert Bednjanec

Vlaska 76 · 10000 Zagreb
T +385 984 16005
robert.bednjanec@net.hr

HU Rath & Co. Ges. m.b.H.

Teiritzstraße 3 · AT-2100 Korneuburg
T +43 2 262 608 0
F +43 2 262 608 60
office@rath-co.at · www.rath-co.at

ID FIBRO Asia Pte. Ltd.

9, Changi South Street 3, #07-04
Singapore 486361
T +65 65 43 99 63 · F +65 65 43 99 62
info@fibro-asia.com · www.fibro.com

IE Bruderer UK Ltd.

Unit H, Cradock Road
Luton · Bedfordshire LU4 0JF
T +44 1582 563 400
F +44 1582 493 993
mail@bruderer.co.uk
www.bruderer-presses.com

IL A. J. Englander 1980 Ltd.

13 Harehev Street · Tel Aviv 67771
T +972 3 537 36 36
F +972 3 537 33 25
info@englander.co.il · www.englander.co.il

IN FIBRO INDIA

PRECISION PRODUCTS PVT. LTD.

Plot No: A-55, Phase II, Chakan MIDC
Taluka Khed, Pune - 410 501
T +91-2135 67 09 03
M +91-98810 00273
info@fibro-india.com · www.fibro.com

IT Millutensil S.R.L.

Corso Buenos Aires, 92 · 20124 Milano
T +39 02 2940 4390
F +39 02 204 6677
info@millutensil.com
www.millutensil.com

KR FIBRO Korea Co. Ltd.

203-603, Bucheon Technopark
Ssangyong 3 · 397, Seokcheon-ro, Ojeong-
gu, Bucheon-si, Gyeonggi-do
T +82 32 624 0630
F +82 32 624 0631
fibro_korea@fibro.kr · www.fibro.com

LI FIBRO GmbH · 74855 Hassmersheim

Angebote: ac5.normalien@fibro.de
T +49 6266 73-439
F +49 6266 9205 670
Bestellungen: vc5.normalien@fibro.de
T +49 6266 73-468
F +49 6266 9205 671

LT Cle Baltic Oü

Pramones gatve 94-7
11115 Vilnius, Lithuania
T +370 663 56309 · F +370 520 40914
info@clebaltic.com · www.clebaltic.com

LV Cle Baltic Oü

Starta iela 6b · 1026 Riga, Latvia
T +371 671 39991 · F +371 671 39992
info@clebaltic.com · www.clebaltic.com

MA Chiba Industrie

Lot 59 Zone Industrielle · Mohammedia
T +212 523 31 40 16/17/19
F +212 523 30 39 85
h.hind@chibaindustrie.com

MX FIBRO Inc.

139 Harrison Ave. · Rockford, IL 61104
T +1 815 229 1300
F +1 815 229 1303
info@fibroinc.com · www.fibro.com

MY FIBRO Asia Pte. Ltd.

9, Changi South Street 3, #07-04
Singapore 486361
T +65 65 43 99 63 · F +65 65 43 99 62
info@fibro-asia.com · www.fibro.com

NL Jeveka B.V.

Platinaweg 4 · 1362 JL Almere Poort
T +31 36 303 2000
info@jeveka.com · www.jeveka.com

NZ APS Tooling Ltd.

17A Spring Street
Onehunga, Auckland, 1061
T +64 9 579 2208 · F +64 9 579 2207
info@apstools.co.nz

PE Ing. E. Brammertz S.c.r.l.

Av. José Pardo 182 · OF. 905
Apartado 0173 · Miraflores, Lima 18
T +51 1 445 81 78 · F +51 1 445 19 31
braming@terra.com.pe

PL Doradca Techniczny Marcin Piętko

Roczyny, ul. Bielska 8 · 34-120 Andrychow
T +48 33 813 72 13
M +48 605 987 284
m.pietka@fibro.de · www.fibro.com

Doradca Techniczny Piotr Kaszuba

ul. Chopina 12/1 · 56-400 Oleśnica
T +48 71 398 53 08
F +48 71 398 53 08
M +48 609 987 285
p.kaszuba@fibro.de · www.fibro.com

REPRESENTACIONES · PRZEDSTAWICIELSTWA · ZASTOUPENÍ · MÜMESSILLER · 代表处

INTERNATIONAL

PT Ferrometal Lda.

Estrada Manuel Correia Lopes
Parque Industrial Progresso, Armazém 1
Polima
2785-001 S. Domingos de Rana
T +351 214 447 160
F +351 214 447 169
ferrometal@ferrometal.pt

RO Reprezentant Vanzari

Daniel Andrei Sibisan

Str. Zizinului nr. 8, ap. 21
Brasov, 500414
T +40 744 44 05 83
F +40 368 78 00 08
d.sibisan@fibro.de · www.fibro.com

RS Andrija Tesic, Dipl. Ing.

Partisanska 12/a-II · 11090 Beograd
T +381 11 2338 362
F +381 11 2338 362
atesic@verat.net

RU CL Engineering & Co. Ltd.

ul. Sofyiskaya 66 · 192289 S. Petersburg
T +7 812 575 1592
F +7 812 324 7388
info@cleru.ru · www.cleru.ru

RU 000 VTF Instrumsnab

ul. Topolinaya 9A · 445047 Togliatti
T +7 8482681424 · F +7 8482681452
office@instrumsnab.ru
www.instrumsnab.ru

SA Abdul Rahman I. Fallatah Br. Est.

Old Makkah Road - Kilo 3
Dar Al Oloum Street
P. O. Box 31403 · Jeddah 21497
T +966 12 681 13 91
F +966 12 645 85 39
fibro.sa@gmail.com · www.al-rasha.com

SE Lideco AB

Verkstadsvägen 4 · 51463 Dalstorp
T +46 321 53 03 50 · F +46 321 603 77
info@lideco.se · www.lideco.se

SG FIBRO Asia Pte. Ltd.

9, Changi South Street 3, #07-04
Singapore 486361
T +65 65 43 99 63 · F +65 65 43 99 62
info@fibro-asia.com · www.fibro.com

SI Oro-Tech trgovina d.o.o.

Ulica borcevc 1/b · SI-2000 Maribor
T +386 2 426 08 43
F +386 2 426 08 44
oro-tech.trgovina@siol.net

SK Technicky konzultant

Vladimir Tanecká

CSA 89/8 · 96223 Ocova
M +421 905 32 94 56
v.tanecka@fibro.de · www.fibro.com

TH FIBRO Asia Pte. Ltd.

9, Changi South Street 3, #07-04
Singapore 486361
T +65 65 43 99 63
F +65 65 43 99 62
info@fibro-asia.com · www.fibro.com

TR Ender Kesici ve Teknik Takımlar

Sanayi Ticaret A.S.

Tersane Caddesi No. 105
34420 Karaköy/Istanbul
T +90 212 253 2600
F +90 212 254 5791
info@enderltd.com · www.enderltd.com

TW SunNan Enterprises Co. Ltd.

2F, No. 7, Alley 6, Lane 235
Pao-Chiao Road
Hsin-Tien City · Taipei
T +886 22917 6454
F +886 22911 0398
sun-ss@umail.hinet.net

US FIBRO Inc.

139 Harrison Ave. · Rockford, IL 61104
T +1 (815) 229-1300
F +1 (815) 229-1303
info@fibroinc.com · www.fibro.com

ZA Herrmann & Herrmann Pty. Ltd.

9, Mpande Street · Sebenza
Edenvale 1609
T +27 11 828 01 00
F +27 11 828 60 21
hermstools@mweb.co.za
www.hermstools.com



Experience and expertise
you can rely on
FIBRO Quality Assurance



Experience and expertise you can rely on FIBRO Quality Assurance

FIBRO is renowned for its quality world-wide. This high quality is achieved through our dedication and commitment to Quality Assurance.

FIBRO testing starts on the raw material and continues right through production to the completed product. The test facilities themselves are also subject to stringent continuous testing. Only by setting itself such stringent standards can a company support its customers long term in safety, cost-effectiveness and quality.

Tests during production

Precision shape and contour testing equipment is used directly in production. This ensures early confirmation of the quality of the product.

The shape testing equipment tests for qualities such as roundness, concentricity, straightness and rectangularity.

FIBRO state of the art technology provides 3D visualisation of concentricity, coaxiality and cylindricity.

Materials testing - raw materials to specification

The FIBRO laboratories carry out microscopic investigation of the raw materials, including enlargement to 2,500 times natural size.

Spectral analysis determines whether the material is correct in terms of chemical composition.

Hardening – hardness testing

All the process parameters in the hardening process in our own hardening shop are recorded and documented.

Hardness testing is used to monitor the results of the hardening process on every batch.

Final tests

For precision at micro level if certain basic requirements have to be met. It goes without saying that the temperature of the measuring room at FIBRO is kept at 20°C. Here the fine precision FIBRO products are measured after production before being released to the customer.

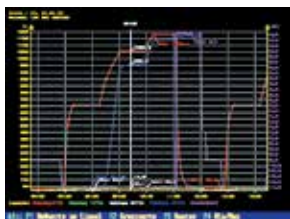
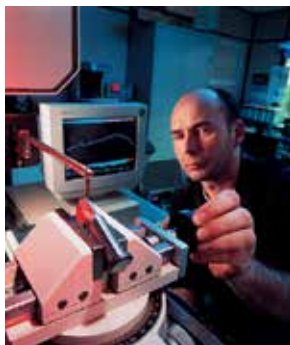
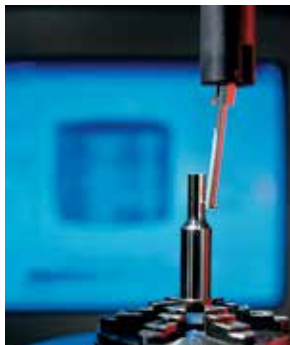

FIBRO – CAM UNIT CONFIGURATOR

FIBRO offers a comprehensive cam unit portfolio for various requirements. The FIBRO - Cam unit configurator on our Internet site will assist you with the selection of the matching cam unit for your application.

The configuration of your cam unit is done in four steps:

1. Angle
2. Cam unit type
3. Width of working surface (min.)
4. Height of working surface (min.)

After this, an initial hitlist with max. 10 matches will be displayed. Further restrictions can be used to narrow down the selection list:

5. Cam unit working stroke (min.)
6. Cam unit working force (min.)
7. Retraction force (min.)
8. Life time

Link to the cam unit configurator:
<http://keilnormschieber.fibro.de/>



Product groups

[Standard Parts Webshop](#)

Webshop instructions

[CAD data via FIBRO](#)

[PART Community](#)

[Cam slide unit configuration assistant](#)

[Gas spring configuration wizard](#)

Contact person

[Sales Management](#)

Downloads

[» Close configurator](#)
[» Reset](#)

Cam slide unit configuration assistant
to select the cam slide units appropriate for you

Print

1. Angle

5 ▾

2. Slide type

Aerial cam ▾

3. Width of working surface min.

60 ▾

4. Height of working surface min.

75 ▾

5. Slide working stroke min.

21 ▾

6. Slide working force min. [kN]

1700 ▾

7. Spring return force min. [N]

1700 ▾

8. Service life

1,000,000 ▾

Your result list

Item	Detail view
2016.24.006.05.2000.00	Detail view
2016.207.05.070.021.2	Detail view
2016.23.05.075.035.2A	Detail view
2016.23.05.075.035.2B	Detail view
2016.207.05.080.035.2	Detail view
2016.24.008.05.1000.00	Detail view
2016.24.011.05.1000.00	Detail view
2016.23.05.150.035.2A	Detail view
2016.23.05.150.035.2B	Detail view
2016.24.015.05.1000.00	Detail view

[Open contact form](#)

CONTENT NUMERICALLY LISTED BY ORDER NUMBER

Order number	Width [mm]	Aerial/ die mounted cam	Page
2016.11.	52 – 400	DMC	Request catalogue 2.2911.
2016.12.	65 – 150	DMC	Request catalogue 2.2911.
2016.14.	52 – 400	DMC	Request catalogue 2.2911.
2016.207.	70 – 400	AEC	219
2016.208.	500 – 1000	AEC	259
2016.21.	65 – 200	AEC	Request catalogue 2.2911.
2016.22.	65 – 200	AEC	Request catalogue 2.2911.
2016.23.	50 – 300	AEC	Request catalogue 2.2911.
2016.24.	60 – 600	AEC	53
2016.25.	700 – 1050	AEC	175

CONTENT BY OEM APPROVAL

OEM	Order number	Width [mm]	Aerial/ die mounted cam	Page
BMW	---			---
Daimler				
	2016.12	65 - 150	DMC	Request catalogue 2.2911.
	2016.23.	50 - 300	AEC	Request catalogue 2.2911.
	2016.24.	60 - 600	AEC	53
	2016.25.	700 - 1050	AEC	175
Ford	---			---
Opel	---			---
PSA				
	2016.23.	50 - 300	AEC	Request catalogue 2.2911.
Renault				
	2016.12.	65 - 150	DMC	Request catalogue 2.2911.
	2016.14.	52 - 400	DMC	Request catalogue 2.2911.
	2016.22.	65 - 200	AEC	Request catalogue 2.2911.
	2016.23.	50 - 300	AEC	Request catalogue 2.2911.
Volvo				
	2016.11.	52 - 400	DMC	Request catalogue 2.2911.
	2016.12.	65 - 150	DMC	Request catalogue 2.2911.
	2016.14.	52 - 400	DMC	Request catalogue 2.2911.
	2016.21.	65 - 200	AEC	Request catalogue 2.2911.
	2016.22.	65 - 200	AEC	Request catalogue 2.2911.
	2016.23.	50 - 300	AEC	Request catalogue 2.2911.
	2016.24.	60 - 600	AEC	53
	2016.25.	700 - 1050	AEC	175
Volkswagen Group with corporate brands				
	2016.12.	65 - 150	DMC	Request catalogue 2.2911.
	2016.24.	60 - 600	AEC	53
	2016.25.	700 - 1050	AEC	175

Processing status: 17.08.2016

Are you missing an OEM in this listing?

Ask us for the latest release list or check our website

<http://www.fibro.de/de/normalien/produktgruppen/k-schieber.html>.

CONTENT BY TYPE

	Order number	Width [mm]	Page
Aerial cam unit	2016.207.	70 - 400	219
	2016.208.	500 - 1000	259
	2016.21.	65 - 200	Request catalogue 2.2911.
	2016.22.	65 - 200	Request catalogue 2.2911.
	2016.23.	50 - 300	Request catalogue 2.2911.
	2016.24.	60 - 600	53
	2016.25.	700 - 1050	175
Die mounted cam unit	2016.11.	52 - 400	Request catalogue 2.2911.
	2016.12.	65 - 150	Request catalogue 2.2911.
	2016.14.	52 - 400	Request catalogue 2.2911.

OVERVIEW SPECIFICATIONS

	Sliding pair	Features	Guaranteed number of strokes / lifetime	Working angle	Angle Increments (step size)	Width [mm]
2016.11. DIE MOUNT CAM STANDARD			Request catalogue 2.2911.!			
	Sliding planes: Cast / Cast with solid lubricant	unpopulated with compression spring	300,000	0°	--	52 – 400
2016.12. HORIZONTAL BAK STANDARD			Request catalogue 2.2911.!			
	Sliding planes: Hardened steel / bronze with solid lubricant	Fully equipped, shouldered guide bars, gas springs correspond to the NAAMS standard	1,000,000	0°	--	65 – 150
2016.14. HORIZONTAL			Request catalogue 2.2911.!			
	Sliding planes: Hardened steel / bronze with solid lubricant	Partly populated with compression spring	600,000	0°	--	52 – 400
2016.207. AERIAL CAM ECO LINE						
	Sliding planes: Hardened steel / bronze with solid lubricant	Fully equipped Guide bars Gas spring	1,000,000	0° – 60°	5°	70 – 400
2016.208. AERIAL CAM ECO LINE						
	Sliding planes: Hardened steel / bronze with solid lubricant	Fully equipped, Guide bars, gas spring	1,000,000	0° – 60°	10°	500 – 1000
2016.21. AERIAL CAM STANDARD			Request catalogue 2.2911.!			
	Sliding planes: Cast / Cast with solid lubricant	unpopulated with screw compression spring	300,000	0° – 70°	10°	65 – 200

OVERVIEW SPECIFICATIONS

	Sliding pair	Features	Guaranteed number of strokes / lifetime	Working angle	Angle Increments (step size)	Width [mm]
2016.22. AERIAL CAM			Request catalogue 2.2911.!			
	Sliding planes: Hardened steel / bronze with solid lubricant	Fully equipped, shouldered Guide bars, prismatic guide, Gas spring	1,000,000	0° – 70°	10°	65 – 200
2016.23. AERIAL CAM KBV1			Request catalogue 2.2911.!			
	Sliding planes: Hardened steel / bronze with solid lubricant	Fully equipped, shouldered Guide bars, gas springs correspond to the NAAMS standard	1,000,000	0° – 60°	5°	50 – 300
2016.24. AERIAL CAM FCC			Request catalogue 2.2911.!			
	Sliding planes: Hardened steel / bronze with solid lubricant	Fully equipped, shouldered Guide bars; sliding guide as double prismatic guide; gas spring, fulfils the BAK contract specification	1,000,000	0° – 75°	5°	60 – 600
2016.25. AERIAL CAM FCC			Request catalogue 2.2911.!			
	Sliding planes: Hardened steel / bronze with solid lubricant	Fully equipped, shouldered Guide bars, gas spring, fulfils the BAK contract specification	1,000,000	0° – 75°	5°	700 – 1050
2016.34. SLOPED			Request catalogue 2.2911.!			
	Sliding planes: Hardened steel / bronze with solid lubricant	Partly populated with compression spring	600,000	10° – 20°	10°	65 – 150

INTRODUCTION AND TABLE OF CONTENTS

ENGINEERING

2016.24. AERIAL CAM FCC BAK

DAIMLER, VOLVO,
VOLKSWAGEN GROUP

2016.25. AERIAL CAM FCC BAK

DAIMLER, VOLVO,
VOLKSWAGEN GROUP

2016.207. AERIAL CAM ECO LINE

2016.208. AERIAL CAM ECO LINE

CUSTOMER-SPECIFIC SERVICES

APPENDIX

EMERGENCY SITUATION / CONTACTS



DESIGN, CONSTRUCTION

ENGINEERING

The FIBRO cam unit program offers matching system solutions for the widest range of applications. From the use in progressive punching tools with the smallest dimensions up to the demanding use in large tools. From the use in tools with small piece numbers up to premium applications in the manufacture of bodywork parts with the highest requirements in terms of precision, lifetime and process force transmission, our cam unit program offers the matching solution to your application. The fault-free operation is guaranteed by FIBRO over the guaranteed, nominal lifetime. The design of the cam units, in the course of the tool construction, is indispensable in this regard. Operating conditions of the tool, as well as the expected environmental influences, must be taken into account to the best extent possible. Using a precise and conscientious design, it is possible to achieve a lifetime which extends far beyond the guaranteed stroke rate.

The desired lifetime can only be achieved by using the cam units as intended. An overloading of the cam units will reduce the number of strokes of the cam unit and can, in the extreme case, lead to the immediate failure of the cam unit during the initial strokes.

The operational reliability of FIBRO cam units is demonstrated by the guaranteed number of strokes. The size of the working force, the position of the center of the force on the working surface and the sequence of the introduction of the force, all have an effect on the system. All performance specifications were calculated using factors known to us at the time of printing. Changed operation conditions can influence the lifetime of the cam unit and must be taken into account separately in consultation with the operator.

FIBRO supports you competently throughout the entire process chain: Starting with the selection of a suitable cam unit for your application, to the correct design, up to the delivery of the cam unit to the assembly, FIBRO is by your side when you have questions. After the completion of the engineering and assembly phase, FIBRO's after-sales support also provides you with professional support for your needs. Take advantage of our experience as a standard system supplier for toolmaking and customise your tools with our products to your specific applications in the most optimal way.

Content overview chapter “ENGINEERING”

Definition of terms	20
Legend / parameter directory	22
Design tool connection	23
Cam unit design	26
Proof of lifetime	33
Retraction and resetting force	34
Calculation examples	35
Load-optimising measures	44
Protrusion box	50

ENGINEERING

DEFINITION OF TERMS

Aerial cam unit (I)

Die mounted cam unit (II)

Installed state,
Depicted 100 mm in front of bottom dead center

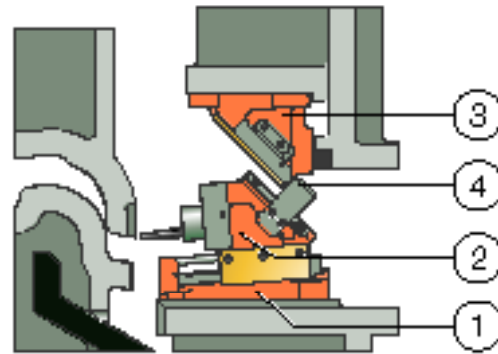
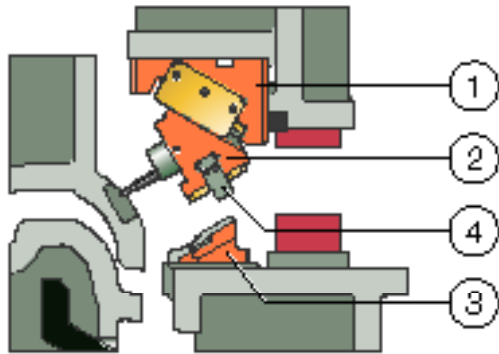

Cam unit mounted in the upper die:
Lifts with upper die during the course of the press cycle.

Cam unit mounted in the lower die:
Remains seating on the lower die during the course of the press cycle.

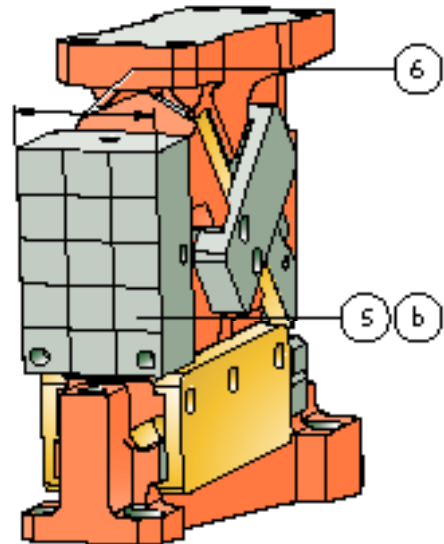
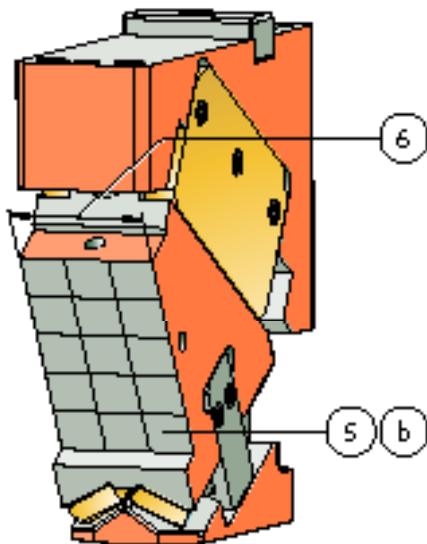

Cam diagram (A)

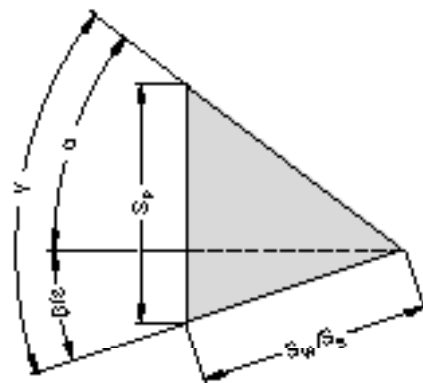
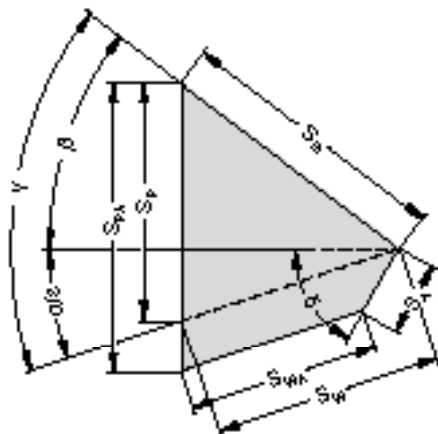

ENGINEERING

DEFINITION OF TERMS

(I)	Aerial cam unit	Assembly cam base / cam slider is mounted in the upper die, the driver in the lower die. Aerial cams are preferably utilised to increase press cycle times.
(II)	Die mounted cam unit	Assembly cam base / cam slider is mounted in the lower die, the driver in the upper die. Die mounted cam units improve the tool dynamics, since the moved mass is reduced in the upper die.
(1)	Cam base	Assembly for receiving the traveling slide body.
(2)	Cam slider	Assembly with the working surface for accommodating the tool-specific components. The cam slider assembly is mounted in the cam base so that it travels linearly.
(3)	Cam driver	Component or assembly which drives the slider body in the course of the press movement.
(4)	Positive return	Constructional device on the cam unit, which retracts the slide body mechanically during the upwards stroke of the press into the initial position.
no figure	Pre-acceleration	Constructional device on the cam unit, which influences the acceleration and braking behaviour of the cam slider in the press stroke. Version as plate or roll pre-acceleration possible.
(5)	Working surface	Surface on the cam slider for accommodating the tool-specific components.
(6)	Working width	Width of working surface
no figure	Maximum permissible working force	Maximum permissible force acting perpendicular to the working surface, with which the cam unit achieves the nominally guaranteed lifetime.
(b)	Force diagram	Specifies the maximum permissible working force when the centre of the force is located in different sectors on the working surface.
no figure	Stripper force	The force required by the parameters of the working process, which is necessary to return the tools to the initial position (tool / process-condition) after reaching the presses bottom dead center.
no figure	Retraction force	Constructionally related force of the cam unit, which returns it to the starting position after reaching the presses bottom dead center.
no figure	Return force	Force which is necessary in order to return the cam slider in the cam base back to the initial position without the action of a process-related stripper force.
no figure	Spring force	Constructionally related nominal force of the spring component used in the cam unit
(A)	Cam diagram	Represents the angle and distance ratios of the cam unit.
(ε)	Cam angle	Operating direction of the cam unit - angle of the cam unit working direction measured to the horizontal.
(α)	Driver angle	Angle of the driver gliding surface measured to the horizontal.
(β)	Base angle	Angle of the cam base gliding surface measured to the horizontal.
(γ)	Included angle	Angle of the sliding surfaces on the cam slider between driver and base.
(δ)	Pre-acceleration angle	Angle of the pre-acceleration gliding surface measured to the horizontal.
(S_w)	Cam stroke	Usable stroke in the working direction of the cam unit (representation aerial cam unit with and without pre-acceleration).
(S_s)	Spring stroke	Stroke of the spring in the cam unit.
(S_p)	Press stroke	Distance in the press direction required to close the cam unit completely.
(S_A)	Pre-acceleration stroke	Stroke which the cam unit travels when a pre-acceleration mechanism is used in the direction of the latter.

ENGINEERING

LEGEND / PARAMETER DIRECTORY

W_T	Cutting work	[Nm]	S_P	Press stroke	[mm]
B	Width	[mm]	S_{PA}	Press stroke with pre-acceleration	[mm]
C_A	Centre of the force of the stripper		S_S	Spring stroke	[mm]
C_B	Centre of working force		S_W	Cam unit stroke	[mm]
C_F	Centre of force		S_{WA}	Cam unit stroke with pre-acceleration	[mm]
C_n	Centre of mass n		t	Time	[s]
D	Diagonal dimension	[mm]	u	Protrusion	[mm]
F	Force	[kN]	u_s	Protrusion to side	[mm]
F_A	Stripper force	[kN]	u_f	Protrusion to front	[mm]
F_B	Operating force	[kN]	B_W	Working width	[mm]
F_{hn}	Horizontal force n	[kN]	x_n	Distance n x-direction	[mm]
F_P	Force for punching	[kN]	y_n	Distance n y-direction	[mm]
F_{pp}	Return force	[kN]	α	Driver angle	[°]
F_R	Retraction force	[kN]	β	Cam base angle	[°]
F_S	Spring force	[kN]	γ	Included angle	[°]
F_T	Cutting force	[kN]	δ	Pre-acceleration angle	[°]
F_{vn}	Vertical force n	[kN]	ε	Cam unit angle	[°]
F_W	Working force	[kN]	τ_T	Shear strength	[N/mm ²]
H	Installation height	[mm]	x_{CA}	Centre of mass of the stripper in x-direction	[mm]
H_1	Distance reference point / support top	[mm]	y_{CA}	Centre of mass of the stripper in y-direction	[mm]
H_n	Height shoulder n	[mm]	x_{Ctotal}	Centre of mass in x-direction, total	[mm]
H_W	Height of the working surface	[mm]	y_{Ctotal}	Centre of mass in y-direction, total	[mm]
K	Cutting contour				
l	Cutting length	[mm]			
l_n	Length contour element n	[mm]			
L	Length	[mm]			
L_1	Distance reference point / stop top	[mm]			
L_2	Clamping surface top	[mm]			
L_3	Distance reference point / stop bottom	[mm]			
L_4	Clamping surface bottom	[mm]			
L_5	Distance reference point to the top edge Working surface	[mm]			
n	Counter				
P_n	Punch counter n				
R_m	Tensile strength	[N/mm ²]			
s	Sheet metal thickness	[mm]			
S	Stroke	[mm]			
S_A	Pre-acceleration stroke	[mm]			

ENGINEERING

DESIGN TOOL CONNECTION

The size of the maximum force transferable by the cam unit is significantly influenced by the type of installation chosen. A technically correct selection of the installation type must be considered analogue to the cam unit design.

The working force can be transmitted via the shoulder of the cam base on FIBRO cam units, alternatively via concealed fitting wedges on the cam base support. The shouldered installation allows maximum load values to be transferred, while a compact mounting space can be realized by installing via the concealed seating wedges. The reduced load values must be observed when installing via the feather keys.

The manufacture of the cam unit interface in the tool can be optimised by means of simple constructional solutions and cost-effectively, without loss of performance.

Force transmission via shoulder

The maximum power values of the cam unit are achieved by the shouldering of the cam base in the nominal shoulder height (see catalogue specifications). It is not necessary to shoulder the die over the entire height of the cam base.

In the following, three possible versions of the shouldering of the cam base in the die are shown, the designs 2 + 3 thereof are preferred since production is optimised.

1. Shouldering over entire cam base height

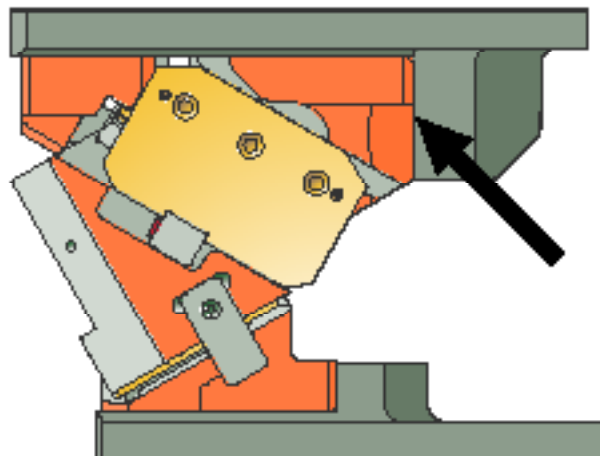

Figure 1: Cam base completely shouldered

ENGINEERING

DESIGN TOOL CONNECTION

- Shouldering via cast shoulder in the upper area of the cam base, lower area exposed

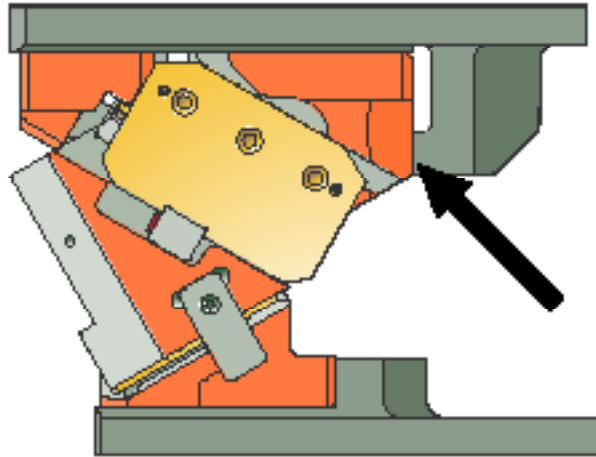

Figure 2: Cam base shouldered at top

- Shouldering via inserted feather key between cam base and die casting in the upper area of the cam base, lower area exposed

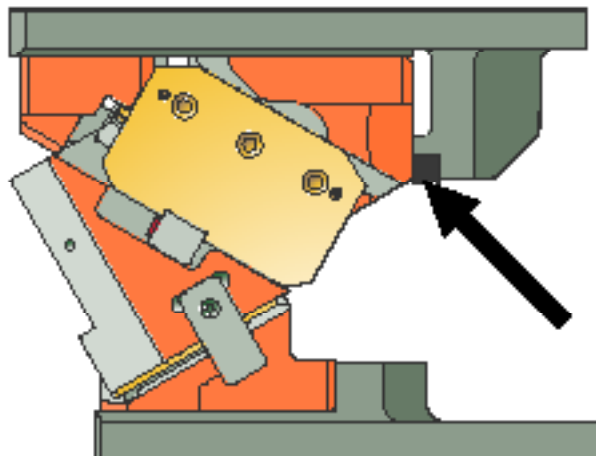

Figure 3: Cam base shouldered at top with key

ENGINEERING

DESIGN TOOL CONNECTION

Force transmission via feather key

In the case of lower requirements on the transmission of force, the cam unit can be installed in the tool by means of bracing via the key so that it is optimised to the installation space. For the mechanical machining of the feather key groove, in this case a distance from the groove geometry to the possible interference geometries in the die cast of at least 140 mm must be observed in order to avoid a collision of the milling spindle.

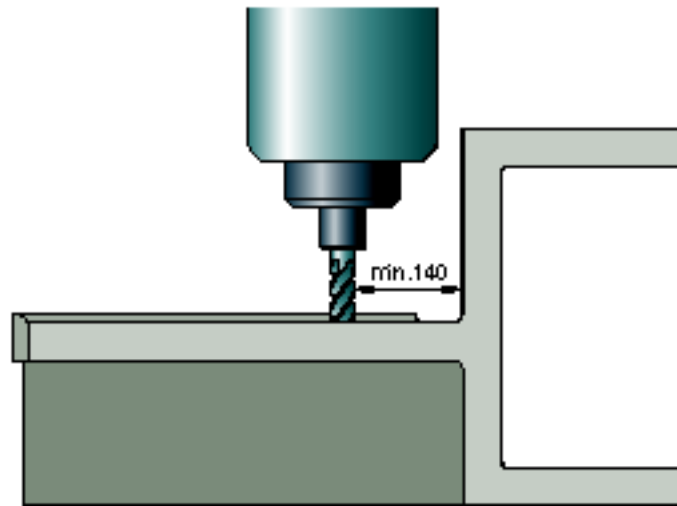

Figure 4: Milling spindle clearance

FIBRO cam units must be fitted with head cap screws having strength class 8.8 or higher.

ENGINEERING

CAM UNIT DESIGN

The operating reliability is demonstrated independently of the operating mode as follows:

1. Evaluation of the calculated operating force
2. Evaluation of the arithmetical centre of force and formation of the substitute force
3. Comparison of the substitute force with permissible force

The operating force is generated by the tools mounted on the cam during the engagement in the sheet metal. When determining the operating forces, the following operating modes are distinguished:

- a) **Cutting**
- b) **Punching**
- c) **Forming**
- d) **Operations with additional stripper**

a) Cutting

During cutting, the operating force is created by overcoming the shear strength of the machined sheet metal part.

The force is calculated using the formula:

$$F_s = l \times s \times \tau_T \quad [1]$$

Cutting length [l] and sheet thickness [s] are taken from the method plan, the shear strength [τ] from material tables. If there are no values for the shear strength, this can be approximately determined from the tensile strength. For ductile materials, this amounts to between 60 and 90% of the tensile strength.

In general, the maximum value of the possible characteristic range of the sheet material must be used as a basis for the calculation because the steel grades are produced and delivered within the specified range. Thus, the characteristic values of the processed sheets can assume the highest permissible characteristic values and thus also the highest possible loads on the tool components can be applied.

For evaluating the cam unit stability, the centre of force applied by the cutting is determined and compared with the force diagram of the desired cam unit. The centre of force of the cutting is determined by means of the centre of mass of the cutting line. For this purpose, complex, free-shaped sections can be dissected into a sufficiently precisely segmented substitute contour with known segment focal points (see Fig. 5)

ENGINEERING

CAM UNIT DESIGN

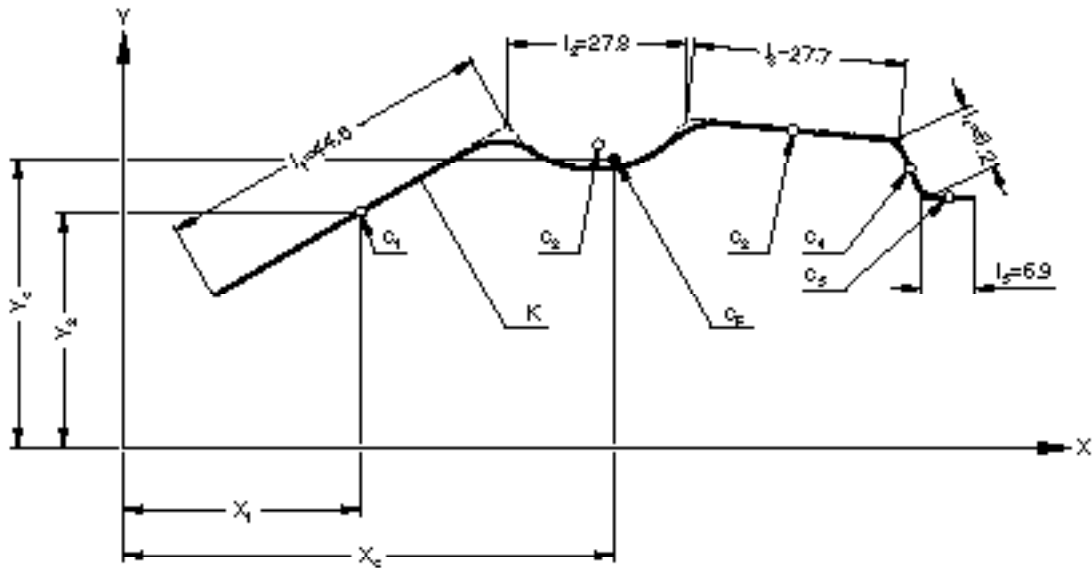

Figure 5: Cutting contour original and approximated

The total centre of force is determined from the individual segments of the line:

x value:

$$x_c = (x_1 \times l_1 + x_2 \times l_2 + x_n \times l_n) / (l_1 + l_2 + l_3) \quad [2]$$

y value:

$$y_c = (y_1 \times l_1 + y_2 \times l_2 + y_n \times l_n) / (l_1 + l_2 + l_3) \quad [3]$$

The following boundary conditions apply to the calculation model:

In this determination of the centre of force, a uniform trim steel engagement is assumed. A non-uniform trim steel engagement determines both the change in the cutting force F_T as well as the centre of the force C_F over the cutting line t_T .

Force-reducing measures such as, for example, the targeted manipulation of the cutting line are not taken into account in this consideration. The modification of the strength values by a cold work hardening of the material in preliminary forming operations is likewise not taken into account in this consideration. It applies in particular to modern, high-strength materials for vehicle structural components (e.g. in dual phase steels) and depends on the material as well as on the degree of metal forming. Cold work hardening effects must be taken into account in the individual case in the design of the cam unit. If a stripper is used on the cam unit, the loading by the stripper must be taken into account accordingly (see section d).

ENGINEERING

CAM UNIT DESIGN

b) Punching

Punching is a special form of cutting. The determination of the operating force thus follows a similar scheme, although some important particulars have to be considered.

The determination of the force is performed analogous to the calculation of the force during cutting. In the case of punching operations, several punches are often arranged on a cam unit. In this case, the force introduced by each punch must be determined as well as the sum of all individual forces.

$$F_{Pn} = I_n \times s \times T_T \quad [4]$$

$$F_{Ptotal} = F_{P1} + F_{P2} + F_{Pn} \quad [5]$$

As a second step, the determination of the centre of the force is carried out analogously to the design during cutting. In contrast to simple cutting, the position of each individual punch and the position of centre of mass of the sum of the individual cells must be examined during punching and compared with the force diagram. This is necessary, since during punching onto a mould surface, each punch engages with a very high probability at a different point in time, and the load in the cam unit is also introduced in a steplike manner.

The centres of the force are calculated as follows:

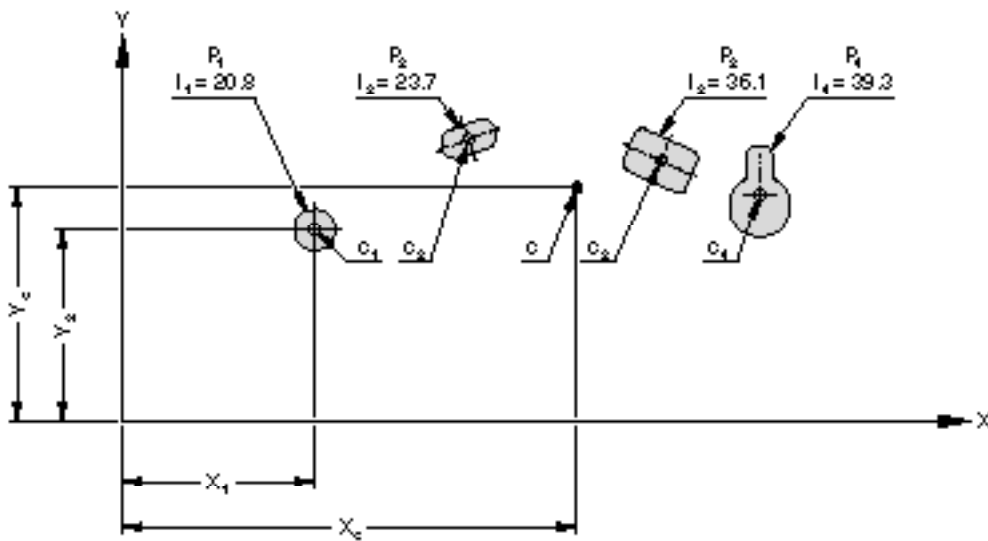

Figure 6: Hole sample

ENGINEERING

CAM UNIT DESIGN

P ₁ (round hole)	>	centre of force in the centre
P ₂ (slot)	>	centre of force in the centre
P ₃ (square hole)	>	centre of force in the centre
P ₄ (shaped hole)	>	determination of the centre by calculating the line centre

In the determination of the total centre of the force of a punching field, the individual cutting lengths of each punch are replaced by the punching forces. The total centre point of the punch field can thus be determined from the individual centre positions:

x value:

$$x_C = (x_1 \times F_{P1} + x_2 \times F_{P2} + x_n \times F_{Pn}) / (F_{P1} + F_{P2} + F_{Pn}) \quad [6]$$

y value:

$$y_C = (y_1 \times F_{P1} + y_2 \times F_{P2} + y_n \times F_{Pn}) / (F_{P1} + F_{P2} + F_{Pn}) \quad [7]$$

Boundary conditions of this calculation model:

In the consideration, a uniform punch engagement of each individual punch is assumed, which is the exception due to the component shape. Tilt and bending of the mould surfaces cause a delayed plunging of the punches. The cutting force reduction by these geometric effects is not taken into account in this calculation model.

The load is changed by the use of a stripper. This must be taken into account in the cam design (see section d)

c) Forming

The term "forming" includes all operations that cause a ductile, permanent form change of the component. The following work operations belong to the forming operating mode:

- Chamfering
- Adjustment
- Postforming
- Drawing

The force required for moulding depends on the shape and the material characteristics. Forming operations on vehicle components are usually complex due to the free form of the components and produce a multi-axial state of stress. The determination of the forces required for this purpose is only possible with difficulty or only with a disproportionate effort. The moulding forces occurring can usually be determined by a drawing simulation. Hard die spotting ("drive to final pressure" / "run against block") with the cam unit is to be avoided if possible. By insufficient coordination of this operation, forces can be introduced into the cam, which exceed the permissible maximum of the allowed operating load by a multiple. Thereby, an immediate failure of the cam unit is possible.

ENGINEERING

CAM UNIT DESIGN

d) Operations with additional stripper

An additional force is introduced into the cam by the use of a stripper resp. cam pad. It is to be taken into account accordingly.

Strippers are used as a stripper plate or as an elastomer / pop-on stripper. The calculation of the centre of force of both variants differs.

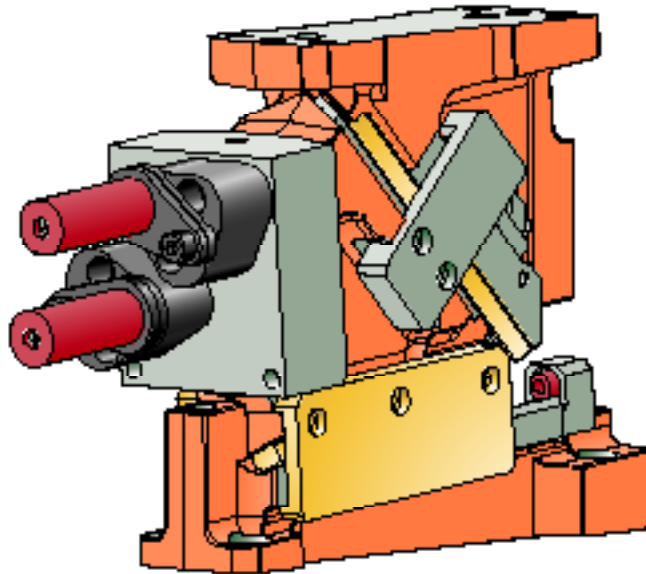

Figure 7: Cam unit with elastomer stripper

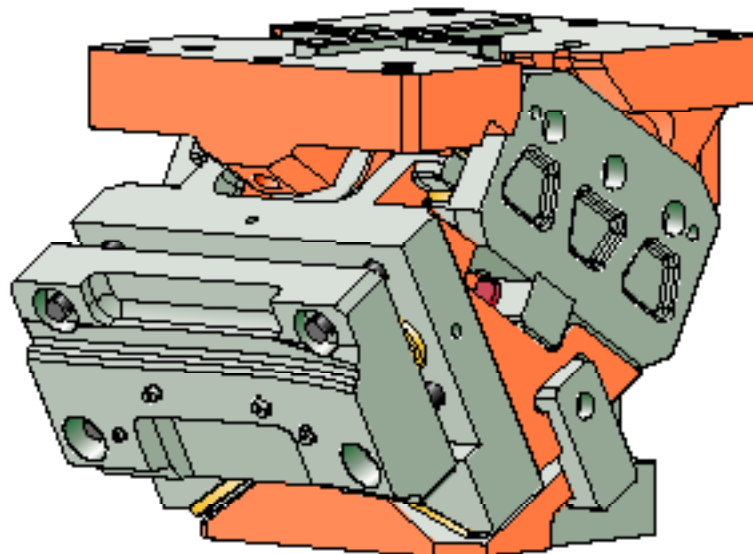

Figure 8: Cam unit with stripper plate

ENGINEERING

CAM UNIT DESIGN

d.1) Elastomer-/Pop-on stripper

Elastomer / Pop-on strippers are extremely compact stripper units, which are directly attached to the supporting plate of a punch. By this arrangement, the centre of mass of an elastomer / pop-on stripper element is centred on the centre axis of the punch.

The total operating force corresponds to the sum of the cutting and stripping force. The centre of mass is then calculated analogous to punching.

d.2) Stripper plate

The centre of the force produced by the stripper plates, in contrast to elastomer / pop-on strippers, is not coincident with the centre of mass force of the working operation. If working with a stripping plate, both the total centre of force of the working operation + stripper plate as well as the centre of force of the stripper plate alone must be compared with the permissible operating force of the cam. This is due to the fact that the load of the stripper plate continues to be present after the fall of the operating force, for example, after punching through the sheet, until the stripper springs are released while opening the die.

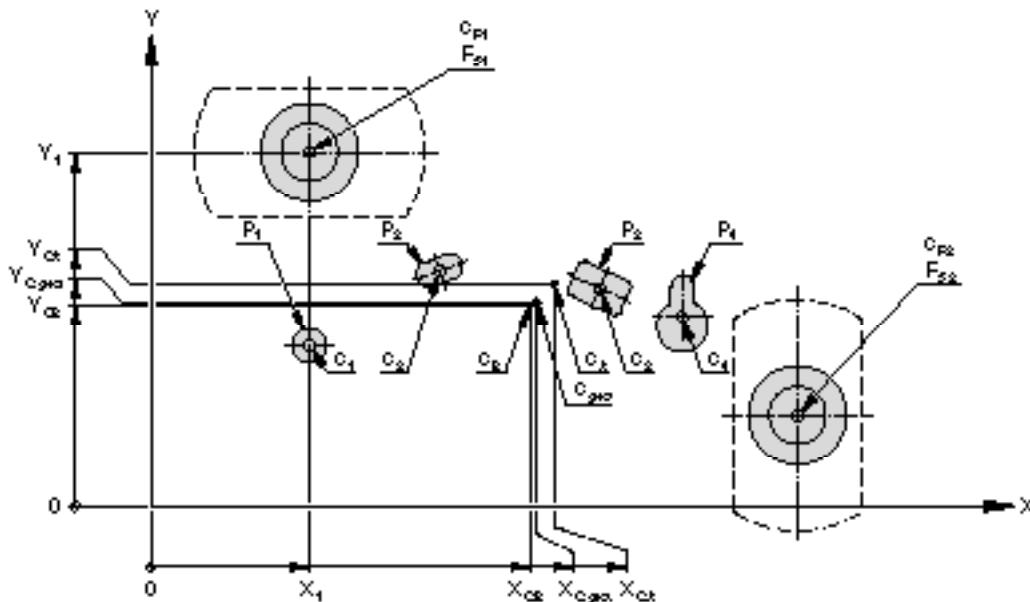

Figure 9: Hole pattern with gas spring

ENGINEERING

CAM UNIT DESIGN

Centre of force of the elastomer / pop-on stripper:

x value:

$$x_{CA} = (x_1 \times F_{S1} + x_2 \times F_{S2} + x_n \times F_{Sn}) / (F_{S1} + F_{S2} + F_{Sn}) \quad [8]$$

y value:

$$y_{CA} = (y_1 \times F_{S1} + y_2 \times F_{S2} + y_n \times F_{Sn}) / (F_{S1} + F_{S2} + F_{Sn}) \quad [9]$$

Total centre of operating force and stripper force:

x value:

$$x_{Ctotal} = (x_{CA} \times \text{Sum } F_S + x_{CB} \times F_B) / (\text{Sum } F_S + F_B) \quad [10]$$

y value:

$$y_{Ctotal} = (y_{CA} \times \text{Sum } F_S + y_{CB} \times F_B) / (\text{Sum } F_S + F_B) \quad [11]$$

ENGINEERING

PROOF OF LIFETIME

The lifetime test is carried out by comparing the existing operating force with the maximum operating force permitted for the guaranteed lifetime. This results in the statement whether or not the cam unit with the introduced force reaches the guaranteed lifetime.

Cutting

The calculated operating force in the determined centre of the force is compared with the permissible operating force from the force diagram of the desired cam unit. The cam unit maintains the guaranteed lifetime if

$$F_B \leq F_{zul} \quad [12]$$

Punching

When punching, each individual punch P_n must be compared with its centre of mass C_n , as well as the sum of all punches with the total centre of the force point, with the force diagram of the desired cam unit. The cam unit maintains the guaranteed lifetime if

$$F_{Bn} \leq F_{zul} \quad [13]$$

and

$$F_{Btotal} \leq F_{zul} \quad [14]$$

Forming

The operating force determined from the drawing simulation and applied at the centre of the force point is compared with the permissible operating force from the corresponding force diagram. The cam unit maintains the guaranteed lifetime if

$$F_B \leq F_{zul} \quad [15]$$

Stripper with cam stripper plate

When a cam stripper plate is used, the sum of the operating force + stripping force, with its associated centre of the force point, as well as the stripping load alone, must be compared with its centre of the force point with the force diagram. The cam unit maintains the guaranteed lifetime if

$$F_A + F_B \leq F_{zul} \quad [16]$$

and

$$F_A \leq F_{zul} \quad [17]$$

General instructions

- The force specifications of the individual force diagram sectors must never be added.
- The substitute force with the corresponding centre of the force point must always be formed in accordance with the preceding descriptions and these must be compared with the force diagram.
- The specifications in the force diagram correspond to the punctually introduced substitute loads and are not surface pressure specifications!

General notes on permissible operating force

As a matter of principle, the transverse loads acting on the cam unit are to be absorbed by design measures in the tool. Uncompensated transverse loads can have a massively negative effect on the cam unit lifetime.

ENGINEERING

RETRACTION AND RETURN FORCE

Determined by the tension conditions and resulting elastic deformations in the machined sheet metal, cutting and forming components stick after the machining process when the bottom dead centre is reached. Accordingly, a stripping force is required to pull the tools out of the sheet into the initial position. For the design of tools, an approximate calculation of the stripping forces, based on experience values, is sufficiently accurate. The stripping force is calculated as a percentage of the working force.

For cutting operations, this amounts to:

$$F_A = 0.07 \times F_T \quad \text{[valid for open cutting contours]} \quad [18]$$

$$F_A = 0.10 \times F_T \quad \text{[valid for closed cutting contours]} \quad [19]$$

In the case of forming operations, the stripping forces vary to a greater degree. When determining the stripping forces during forming operations, the instructions of the tool manufacturers or operators must be observed.

Cam units have a system-related retraction capability. This can be used to overcome the necessary stripping force. If the retraction capacity of the cam unit is higher than the necessary stripping force, no tool-specific actions need to be taken to return the die components to the initial position. In this case, the cam unit can work directly through the main pad of the die.

$$F_R > F_A \quad [20]$$

If the retraction capacity of the cam unit is less than the tool- or process-specific stripping force, then constructional measures need to be provided, such as the use of a cam stripper.

$$F_R < F_A \quad [21]$$

The retraction force specifications of all FIBRO cam units refer to the working direction of the cam unit, thus, a conversion is not necessary.

If an aerial cam unit remains in its bottom dead centre after the working operation, considerable damage to the cam unit and die is to be expected due to collision of die components while opening it.

In contrast, if a die mounted cam remains in its bottom dead centre after the working operation, then no profound damage is to be expected in the event that the cam does not operate through the main pad. As a rule, the die mechanism in this case is not able to remove the blank out of the die, which stops the movement of the machine by means of the mechanisation sensor system.

If the die components of a die mounted cam also operate through the main pad, similar damage to the cam and die as in the case of an aerial cam unit is to be expected.

Please note that for this reason, the mechanical retraction clamps must not be removed without consulting with FIBRO.

ENGINEERING

CALCULATION EXAMPLES

The design for die construction is illustrated by the following three examples.

1. Cutting

a) by main pad

Process parameters:

Cam unit angle 40°

greatest width of the cutting line on cam 278 mm

Cutting contour see figure

Length $l = 305.9$ mm

Sheet metal thickness $s = 0.7$ mm

Material DX51D+Z; max. tensile strength $R_m = 270 \dots 500$ N/mm²

open cutting line: Stripping force 7% of cutting force

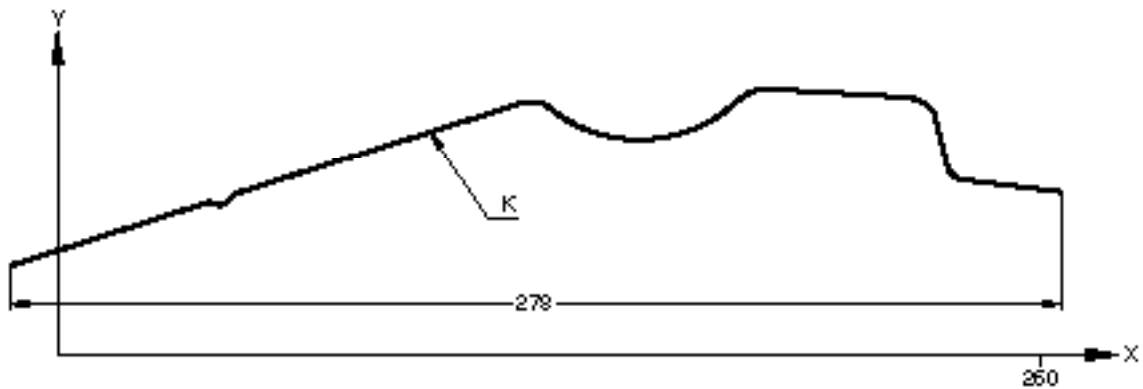

Figure 10: Cutting contour

Determination cutting force F_T (= Operating load F_B)

$$F_T = l \times s \times \delta_T = l \times s \times R_m \times 0.8$$

$$F_T = 305,9 \text{ mm} \times 0.7 \text{ mm} \times 500 \text{ N/mm}^2 \times 0.8$$

$$F_T = 85.7 \text{ kN}$$

Determination stripping force F_A

$$F_A = F_T \times 0.07$$

$$F_A = 85.7 \text{ kN} \times 0.07$$

$$F_A = 6 \text{ kN}$$

ENGINEERING

CALCULATION EXAMPLES

Determination of centre of the force C_F

The cutting contour is segmented into the replacement cutting contour, compare figure. The mass centres of the individual segments of the replacement cutting contour are known.

For the calculation of the total centre of the force, the zero point of the coordinate system is assumed to be $x + 12.5 / y - 23.5$ measured from the left outermost corner of the cutting contour. The lengths, as well as single centre of mass values of the individual contours are as follows (graphically determined values):

No.	Type	Length contour element (mm)	x_C (mm)	y_C (mm)
1	Line	146.7	57.4	45.7
2	Arc	62.8	155.6	61.1
3	Line	48	207.1	69.1
4	Line	21.8	233.7	57
5	Line	29.4	250.9	44.7

The position of the total centre of the force is calculated from the values of the individual segments:

$$x_C = (x_1 \times l_1 + x_2 \times l_2 + x_3 \times l_3 + x_4 \times l_4 + x_5 \times l_5) / (l_1 + l_2 + l_3 + l_4 + l_5)$$

$$x_C = (57.4 \text{ mm} \times 146.7 \text{ mm} + 155.6 \text{ mm} \times 62.8 \text{ mm} + 207.1 \text{ mm} \times 48 \text{ mm} + 233.7 \text{ mm} \times 21.8 \text{ mm} + 250.9 \text{ mm} \times 29.4 \text{ mm}) / (146.7 \text{ mm} + 62.8 \text{ mm} + 48 \text{ mm} + 21.8 \text{ mm} + 29.4 \text{ mm})$$

$$x_C = 131.5 \text{ mm}$$

$$y_C = (y_1 \times l_1 + y_2 \times l_2 + y_3 \times l_3 + y_4 \times l_4 + y_5 \times l_5) / (l_1 + l_2 + l_3 + l_4 + l_5)$$

$$y_C = (45.7 \text{ mm} \times 146.7 \text{ mm} + 61.1 \text{ mm} \times 62.8 \text{ mm} + 69.1 \text{ mm} \times 48 \text{ mm} + 57 \text{ mm} \times 21.8 \text{ mm} + 44.7 \text{ mm} \times 29.4 \text{ mm}) / (146.7 \text{ mm} + 62.8 \text{ mm} + 48 \text{ mm} + 21.8 \text{ mm} + 29.4 \text{ mm})$$

$$y_C = 53.2 \text{ mm}$$

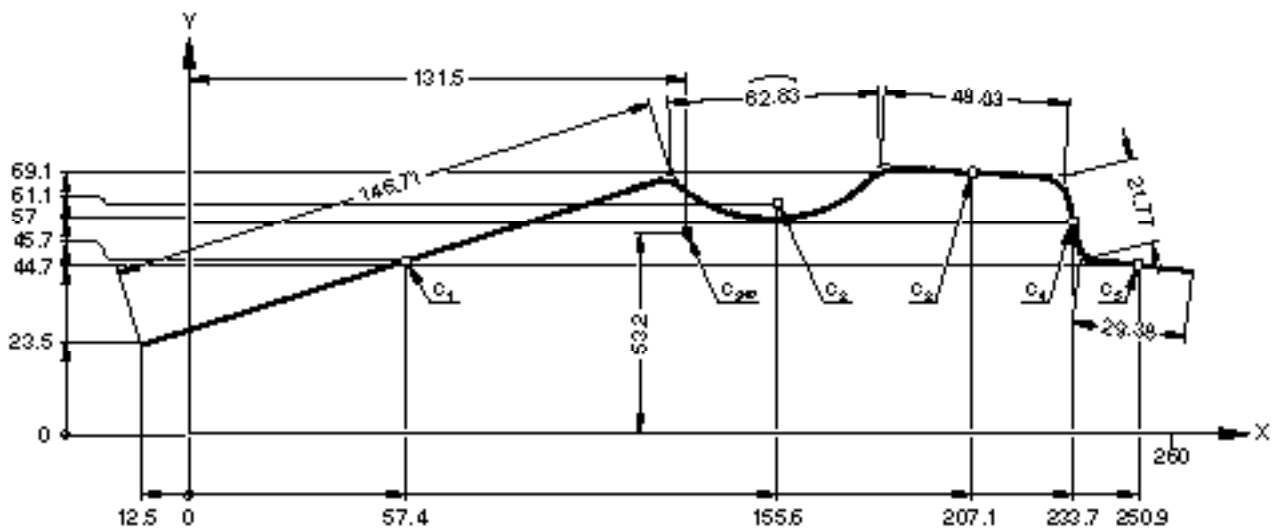

Figure 11: Cutting contour approximated

ENGINEERING CALCULATION EXAMPLES

The determined force values are compared with the performance data of the selected cam unit. For this work operation, an aerial cam unit of the 2016.24. series with a working width of 260 mm is to be used. The cam unit has the following performance data:

- max. working force (shouldered installation): 737 kN
- max. working force (installation with feather key): 359 kN
- Retraction force: 36.4 kN

The total centre of force of the cam cut is on the quadrant of the force diagram with 737 kN permissible load (shouldered) or 320 kN permissible load (installed with feather key). The cam unit can therefore be installed with the given cutting contour and the applied process parameters both with the force relief via a shoulder on the rear side of the cam base as well as via the feather key inserted into the cam base supporting surface in the die:

$$F_T < F_{\text{permissible feather key}} < F_{\text{permissible shoulder}}$$

$$85.7 \text{ kN} < 320 \text{ kN} < 737 \text{ kN}$$

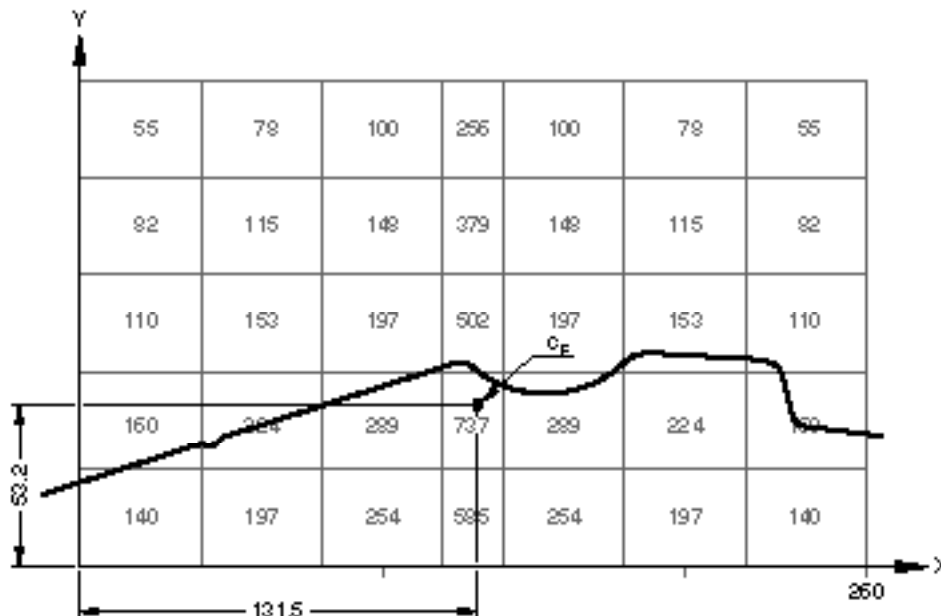

Figure 12: Cutting contour with force diagram

No further actions have to be taken to move the cam unit back in the initial position when the press is opened – the retraction force of the cam unit is higher than the process-induced stripping force:

$$F_R > F_A$$

$$33.6 \text{ kN} > 6 \text{ kN}$$

ENGINEERING

CALCULATION EXAMPLES

2. Punching

a) by main pad

Process parameters: Cam unit angle 15°
 largest distance between punch centres is 72.6 mm
 Punch contours, see figure
 Contour lengths and individual centres of the force, see table
 Sheet metal thickness $s = 1.5 \text{ mm}$
 Material D750MS /+Z; max. tensile strength $R_m = 1,000 \dots 1,200 \text{ N/mm}^2$
 closed cutting line: Stripping force 10% of cutting force

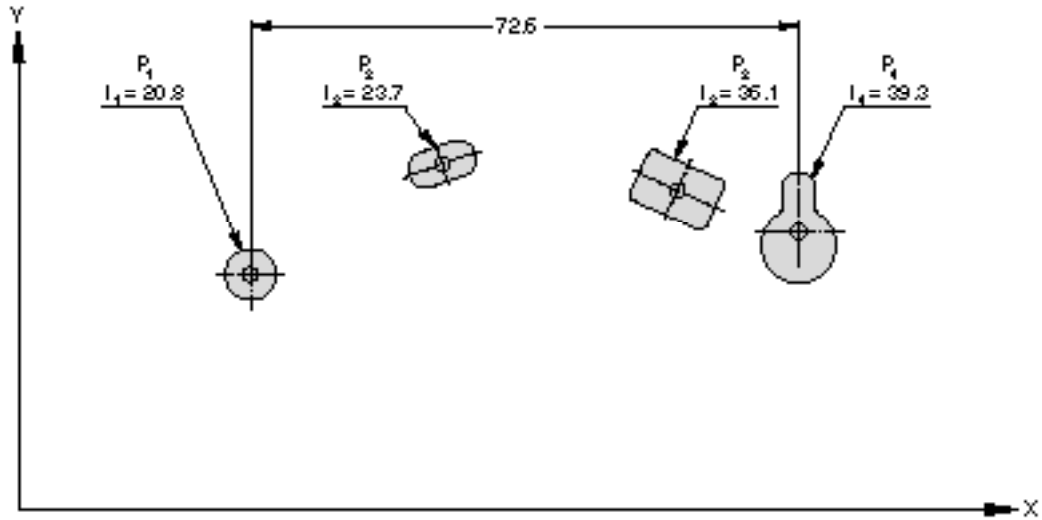

Figure 13: Hole pattern with size estimation

Determination cutting force during punching F_{Pn} (= Operating force F_B)

$$F_p = l \times s \times \delta T = l \times s \times R_m \times 0.8$$

Punch P_1 :

$$F_{P1} = 20.9 \text{ mm} \times 1.5 \text{ mm} \times 1,200 \text{ N/mm}^2 \times 0.8$$

$$F_{P1} = 30.1 \text{ kN}$$

Punch P_2 :

$$F_{P2} = 23.8 \text{ mm} \times 1.5 \text{ mm} \times 1,200 \text{ N/mm}^2 \times 0.8$$

$$F_{P2} = 34.3 \text{ kN}$$

Punch P_3 :

$$F_{P3} = 36.1 \text{ mm} \times 1.5 \text{ mm} \times 1,200 \text{ N/mm}^2 \times 0.8$$

$$F_{P3} = 52 \text{ kN}$$

Punch P_4 :

$$F_{P4} = 39.3 \text{ mm} \times 1.5 \text{ mm} \times 1,200 \text{ N/mm}^2 \times 0.8$$

$$F_{P4} = 56.6 \text{ kN}$$

ENGINEERING

CALCULATION EXAMPLES

Total cutting force F_{Ptotal} during punching:

$$F_{Ptotal} = F_{P1} + F_{P2} + F_{P3} + F_{P4}$$

$$F_{Ptotal} = 30.1 \text{ kN} + 34.3 \text{ kN} + 52 \text{ kN} + 56.6 \text{ kN}$$

$$F_{Ptotal} = 173 \text{ kN}$$

Determination stripping force F_A

$$F_A = F_{Ptotal} \times 0.1$$

$$F_A = 173 \text{ N} \times 0.1$$

$$F_A = 17.3 \text{ kN}$$

Determination of the total centre of the force

The centres of the force of the individual punches are known. For the calculation of the total centre of the force, the zero point of the coordinate system is assumed to be $x + -26.6 / y - 31.2$ measured from the centrepoint of the punch P_1 . The positions of the individual centre of the force values result from the method plan as follows (graphically determined values):

No.	Type	Length (mm)	x_C (mm)	y_C (mm)
P_1	Round hole	20.8	26.6	31.2
P_2	Slot	23.7	51.8	45.9
P_3	Square hole	36.1	83.2	42.5
P_4	Keyhole	39.3	99.3	36.1

The position of the total centre of the force is calculated from the values of the individual punches:

$$x_C = (x_1 \times F_{P1} + x_2 \times F_{P2} + x_3 \times F_{P3} + x_4 \times F_{P4}) / (F_{P1} + F_{P2} + F_{P3} + F_{P4})$$

$$x_C = (26.6 \text{ mm} \times 30.1 \text{ kN} + 51.8 \text{ mm} \times 34.3 \text{ kN} + 83.2 \text{ mm} \times 52 \text{ kN} + 99.3 \text{ mm} \times 56.6 \text{ kN}) / (30.1 \text{ kN} + 34.3 \text{ kN} + 52 \text{ kN} + 56.6 \text{ kN})$$

$$x_C = 72.4 \text{ mm}$$

$$y_C = (y_1 \times F_{P1} + y_2 \times F_{P2} + y_3 \times F_{P3} + y_4 \times F_{P4}) / (F_{P1} + F_{P2} + F_{P3} + F_{P4})$$

$$y_C = (31.2 \text{ mm} \times 30.1 \text{ kN} + 45.9 \text{ mm} \times 34.3 \text{ kN} + 42.5 \text{ mm} \times 52 \text{ kN} + 36.1 \text{ mm} \times 56.6 \text{ kN}) / (30.1 \text{ kN} + 34.3 \text{ kN} + 52 \text{ kN} + 56.6 \text{ kN})$$

$$y_C = 39.1 \text{ mm}$$

ENGINEERING CALCULATION EXAMPLES

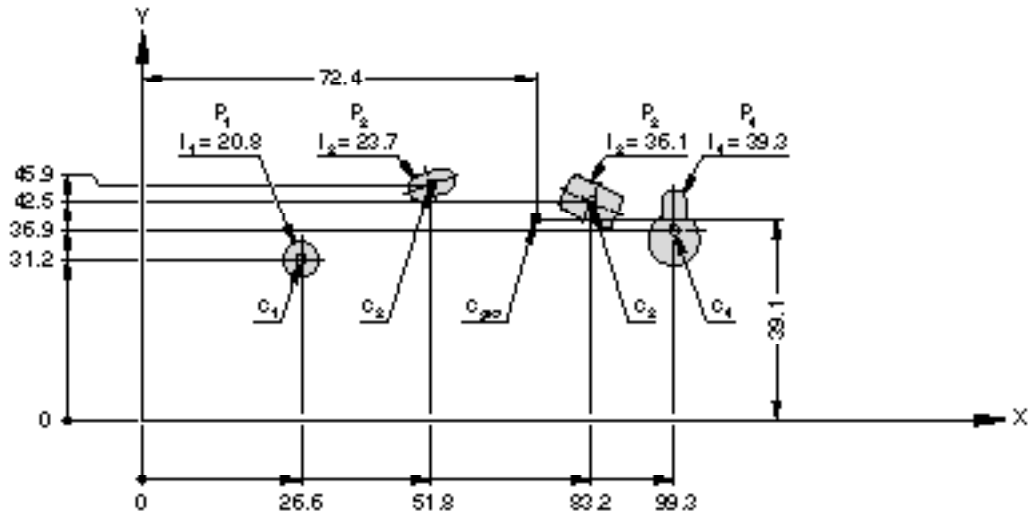

Figure 14: Hole pattern with individual centre of mass

The determined force values are compared with the performance data of the selected cam unit. For this work operation, preferably, a compact aerial cam unit of the 2016.24. series is to be used.

Due to the maximum distance of about 72.6 mm of the centre of mass of the holes, an attempt is made to use a cam unit with a width of 110 mm and a multi-punch retainer plate.

The selected cam unit has the following performance data:
 max. working force (shouldered installation): 372 kN
 max. working force (installation with feather key): 93 kN
 Retraction force: 5.8 kN

The total centre of the force of the hole pattern is on the quadrant of the force diagram with 372 kN permissible load (shouldered) or 80 kN permissible load (installed with feather key). Therefore, the process forces on the cam should absolutely be absorbed by a shoulder on the back of the cam base for the given hole pattern and its process parameters:

$$F_{\text{permissible feather key}} < F_P < F_{\text{permissible shoulder}}$$

$$80 \text{ kN} < 173 \text{ kN} < 372 \text{ kN}$$

The individual centres of the force of each punch lie on quadrants of the force diagram in each case with a higher permissible load than the present operating force. A stepped punching caused by the partial shape thus does not cause any unacceptable overloads on the cam unit. In the following, only the forces with the force diagrams installation type "shouldered" are compared:

Punch P₁:
30.1 kN < 91 kN

Punch P₂:
34.3 kN < 164 kN

Punch P₃:
52 kN < 164 kN

Punch P₄:
56.6 kN < 164 kN

ENGINEERING CALCULATION EXAMPLES

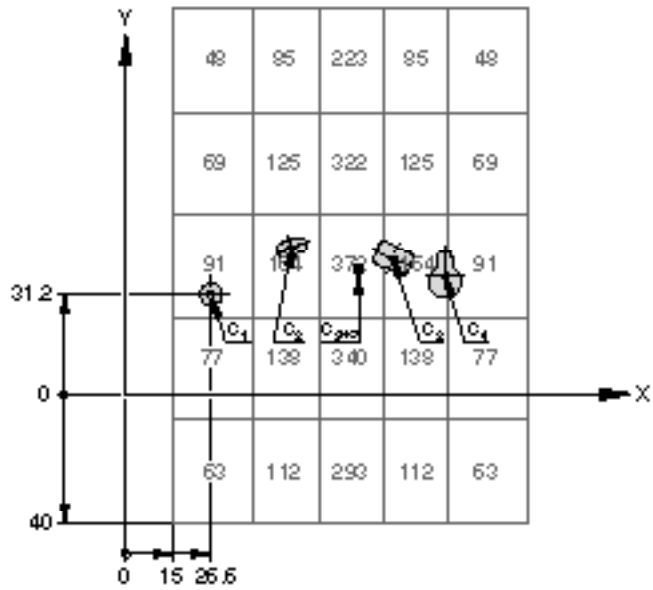

Figure 15: Hole pattern with force diagram

The constructional retraction force of the cam is not sufficient to move the slider back into the initial position while the press opens; the return force of the cam is less than the process-induced stripping force:

$$F_R < F_A$$

$$5 \text{ kN} < 17.3 \text{ kN}$$

Die specific actions must be taken in order to ensure that the slider can be returned. In this case, a cam stripper is used.

b) with gas-spring-operated cam stripper

The cam from point a) is equipped with a gas-spring-operated cam stripper to increase the retraction force. It has to be operated by two or three compact gas springs of the POWERLINE series. According to the design, approx. 12 kN retraction force is missing for a smooth process. Springs of the POWERLINE series with a cylinder diameter of 38 mm have an initial force of 5 kN. For the present case, three springs are thus required for the actuation of the cam pad. The springs are mounted using a square mounting flange. The additional installation space required for this is to be taken into account when selecting the cam unit. As a result of the flange dimensions, the width of the slider working surface must be at least 147 mm. Accordingly, the next largest cam unit width is selected with 150 mm. With approx. 8 kN, this cam unit has a greater retraction capacity than the originally selected cam unit with a width of 110 mm. With this cam unit and the selected gas springs, two pieces are sufficient to actuate the cam stripper. In order to be able to accommodate the guide, retaining and safety elements on the cam unit work surface, to obtain a good distribution of the force introduction, and to realise a compact overall space, the springs are arranged diagonally on the working surface (compare illustration).

ENGINEERING

CALCULATION EXAMPLES

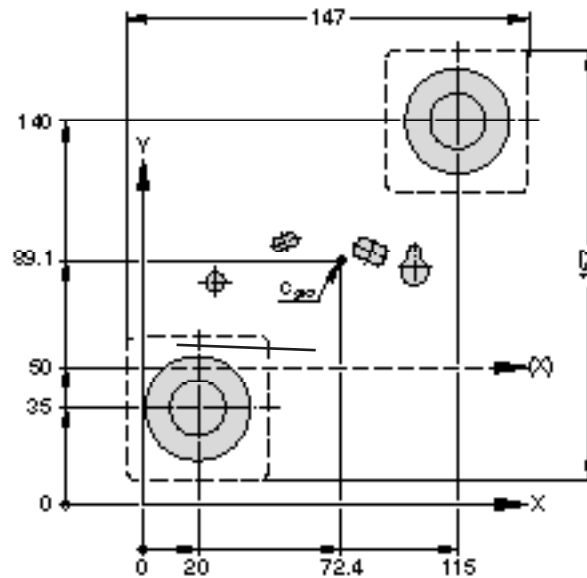

Figure 16: Hole pattern with stripper plate

Determination of the centre of the force of the stripper plate.

Shifted by 50 mm in the y-direction for the calculation, the original reference system:

$$x_{CA} = (x_1 \times F_{S1} + x_2 \times F_{S2}) / (F_{S1} + F_{S2})$$

$$x_{CA} = (20 \text{ mm} \times 5 \text{ kN} + 115 \text{ mm} \times 5 \text{ kN}) / (5 \text{ kN} + 5 \text{ kN})$$

$$x_{CA} = 67.5 \text{ mm}$$

$$y_{CA} = (y_1 \times F_{S1} + y_2 \times F_{S2}) / (F_{S1} + F_{S2})$$

$$y_{CA} = (35 \text{ mm} \times 5 \text{ kN} + 140 \text{ mm} \times 5 \text{ kN}) / (5 \text{ kN} + 5 \text{ kN})$$

$$y_{CA} = 87.5 \text{ mm}$$

Determination of the total centre of the force hole pattern + stripper plate

$$x_{Ctotal} = (x_{CA} \times \sum F_S + x_{CB} \times F_B) / (\sum F_S + F_B)$$

$$x_{Ctotal} = (67.5 \text{ mm} \times 10 \text{ kN} + 72.4 \text{ mm} \times 173 \text{ kN}) / (10 \text{ kN} + 173 \text{ kN})$$

$$x_{Ctotal} = 72.1 \text{ mm}$$

$$y_{Ctotal} = (y_{CA} \times \sum F_S + y_{CB} \times F_B) / (\sum F_S + F_B)$$

$$y_{Ctotal} = (87.5 \text{ mm} \times 10 \text{ kN} + 89.1 \text{ mm} \times 173 \text{ kN}) / (10 \text{ kN} + 173 \text{ kN})$$

$$y_{Ctotal} = 89.0 \text{ mm}$$

The additional cam stripper does not cause any unacceptable operating states. Both the force of each punch, the total force of all punches with their centre of the force, the force of the cam stripper with its centre of the force as well as the total force of all the forces acting with the total centre of the force lie within the permissible forces of the respective quadrant of the cam diagram. The cam must be installed shouldered in the die.

ENGINEERING CALCULATION EXAMPLES

$$\Sigma F_S < F_{\text{permissible feather key}} < F_{\text{permissible shoulder}}$$

$$10 \text{ kN} < 110 \text{ kN} < 439 \text{ kN}$$

$$F_{\text{permissible feather key}} < F_{\text{total}} < F_{\text{permissible shoulder}}$$

$$110 \text{ kN} < 183 \text{ kN} < 439 \text{ kN}$$

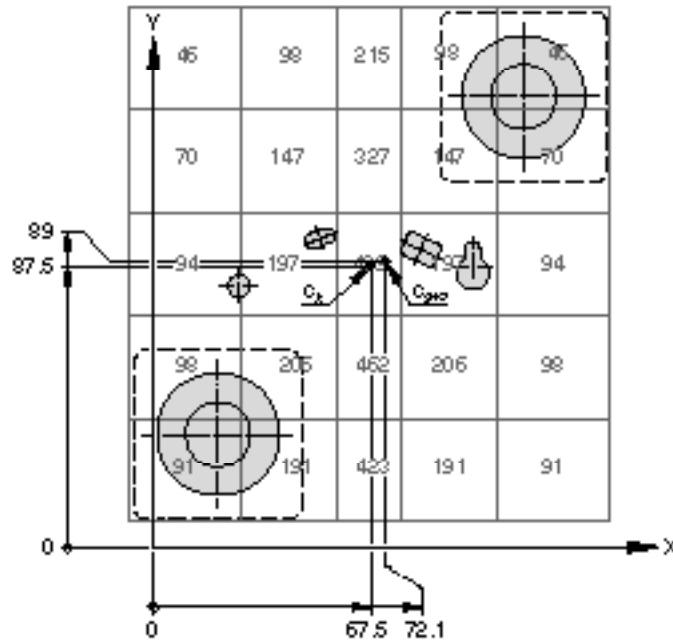

Figure 17: Hole pattern with stripper plate and force diagram

The sum of the retraction force of the cam and stripper is sufficient to move the cam back into the initial position while the press opens:

$$F_R > F_A$$

$$18 \text{ kN} > 17.3 \text{ kN}$$

ENGINEERING

LOAD-OPTIMISING MEASURES

Constructive actions can reduce or compensate operating and secondary loads (e.g. transverse forces). These actions may have effects on the quality of the press part or the manufacturing process. Therefore they have to be coordinated with the operator of the die.

a) Modified trim steel geometry

In the case of a simultaneous trim steel engagement over the entire cutting length, the cutting work is performed over the path of the sheet thickness. The cutting work is calculated from:

$$W_T = F_T \times t$$

If the trim steel geometry is designed in the form of a shear, a roof or a wave, the working path is extended analogous to the selected trim steel shape. The performed cutting work W_T remains unchanged in its size, therefore the necessary cutting force F_T becomes lower.

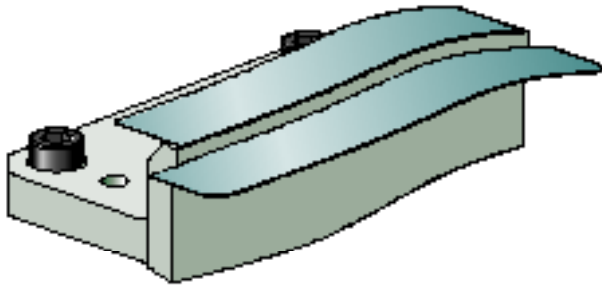

Figure 18: Trim steel with parallel grinding

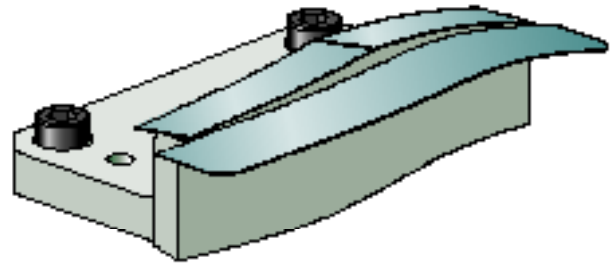

Figure 19: Trim steel with top grinding

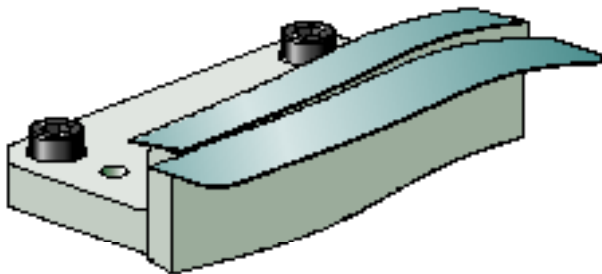

Figure 20: Trim steel with scissors grinding

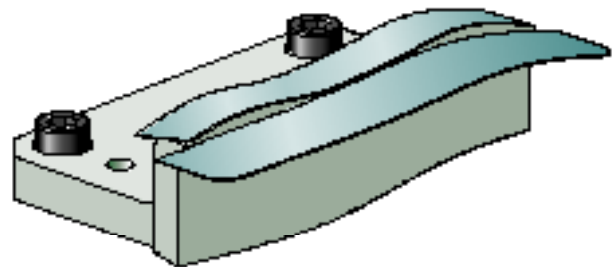

Figure 21: Trim steel with wave grinding

The cutting force can be reduced up to 50% by means of a cutting force reducing design. Due to the geometrically altered design of the trim steels the centre of the force may also vary during the cutting process. A quantitative statement about the centre of the force progression is difficult to determine with trim steels shaped in this way. Due to cam load it's recommended to design the force-optimised trim steels symmetric.

For aluminium press parts, these cutting force reducing actions are not recommended. They can cause uncontrollable, inadmissible process fluctuations here.

ENGINEERING

LOAD-OPTIMISING MEASURES

b) Absorption of transverse forces

Transverse forces cause additional loads on the cam unit components. They add up vectorially to the operating force in the cam direction and thus have a significant influence on the cam unit lifetime. Therefore transverse forces must be compensated by constructive measures in the die in order to prevent system overload. The absorption of the transverse force is preferably performed parallel to the working engagement at the same height.

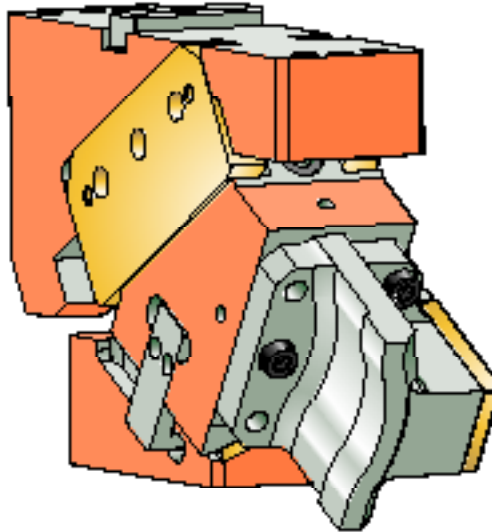

Figure 22: Absorption of transverse force

A simple description of the relationship between the transverse force and the lifetime is not possible since the permissible transverse force depends on the direction of action and the magnitude of the operating force.

C) Dimensioning of the protrusion

Large tool protrusions over the work surface have an influence on the working result, the system load and the lifetime of the cam unit due to geometric and static effects:

- high weight load on cam unit system due to large tool fittings on the work surface
- Multiplication of the effect by transverse forces due to lever mechanisms
- noticeably faster influence on the work result by lever effect through possible changes in the clearance
- changed damping behaviour

In general, you should therefore endeavour to achieve the smallest possible protrusion in the working area. Standard punching lengths (including retainer plate) + approx. 50 mm can be assumed as a guide.

Overhangs in front of the working surface, which go beyond this guideline, are also possible, but must be checked and evaluated in the course of the die design. FIBRO is pleased to advise and support you.

ENGINEERING

LOAD-OPTIMISING MEASURES

d) Application of compensatory forces

In the case of eccentric operating forces, the total force distribution can be positively influenced by introducing compensating forces. Appropriately dimensioned springs are arranged on the work surface for this purpose, which act against the lower die or against the mounted main pad. Through the use of compensating forces, the total force as well as the total centre of the force change. Accordingly, compensating elements must be taken into account during the course of the cam unit design.

Compensation elements behave analogously to slider strippers. Their force continues to be applied after the end of the working process, for example, after cutting through the sheet metal. The centre of the force of the compensating forces must therefore also be compared with the permissible cam forces in order to make a sound statement about the applied cam force possible (solution path, see chapter "Cam stripper").

Example:

The following values are known for one application case:

Process parameters	cam unit:	2016.24.150.015.1000.0
	Working width:	150 mm
	Angle:	15°
	Cutting length l_1 :	42.7 mm
	Cutting length l_2 :	54.5 mm
	Punch contours + possible arrangement,	see figure
	Sheet metal thickness:	1,2 mm
	Tensile strength:	1,000 N/mm ²

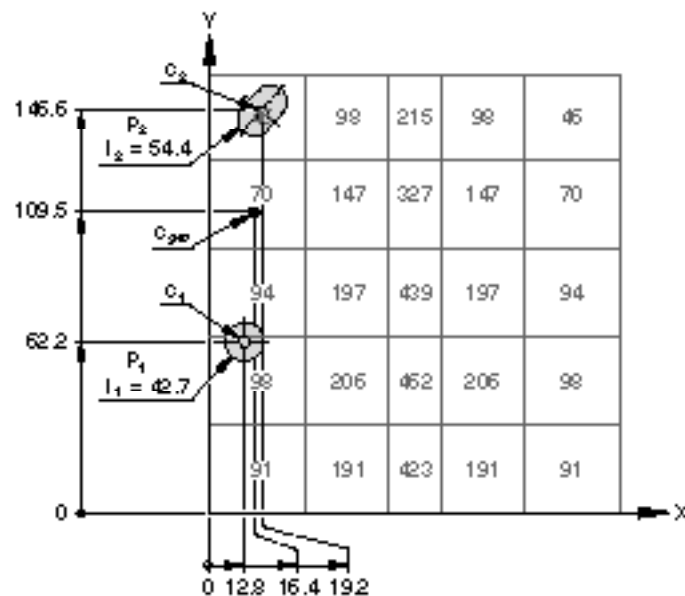

Figure 23: Eccentric hole pattern

ENGINEERING

LOAD-OPTIMISING MEASURES

The forces and centres of the force are as follows:

$$\begin{aligned}
 F_{P_1} &= 41.0 \text{ kN} / x_{C_1} = 12.8 \text{ mm} / y_{C_1} = 62.2 \text{ mm} \\
 F_{P_2} &= 52.2 \text{ kN} / x_{C_2} = 19.2 \text{ mm} / y_{C_2} = 146.6 \text{ mm} \\
 F_{P_{\text{total}}} &= 93.2 \text{ kN} / x_{C_{\text{total}}} = 16.4 \text{ mm} / y_{C_{\text{total}}} = 109.5 \text{ mm}
 \end{aligned}$$

The forces of the cam unit are absorbed by means of a solid cast shoulder on the back of the cam base. Accordingly, the proof of lifetime results after comparison of the forces with the cam load diagram:

$$F_{P_1} < F_{\text{zul}} \quad 41 \text{ kN} < 98 \text{ kN} \quad \rightarrow \text{Loading by punch } P_1 \text{ permissible}$$

$$F_{P_2} > F_{\text{zul}} \quad 52.2 \text{ kN} > 46 \text{ kN} \quad \rightarrow \text{Loading by punch } P_2 \text{ not permissible}$$

$$F_{P_{\text{total}}} > F_{\text{zul}} \quad 93.2 \text{ kN} > 70 \text{ kN} \quad \rightarrow \text{Loading by load sum not permissible}$$

Corresponding to the calculation results, constructive countermeasures must be provided in order to avoid overloading and thus a reduced lifetime of the cam unit. The centre of the force of the punch P2 as well as the total centre of the force must be moved further towards the middle of the cam unit. For this purpose, a compensating spring is to be provided on the working surface of the cam which acts against the main pad of the die:

Selected spring: FIBRO 2487.12.02400.016 (POWERLINE)
 Spring nominal force: 24 kN
 Mounting position x/y: 105 mm / 62.2 mm

By means of this additional spring, the total centre of the force point of the punch P2 and of the spring is shifted to the following coordinates:

$$F_{\text{Compensation}} = 72,6 \text{ kN} / x_{\text{Compensation}} = 46,2 \text{ mm} / y_{\text{Compensation}} = 120 \text{ mm}$$

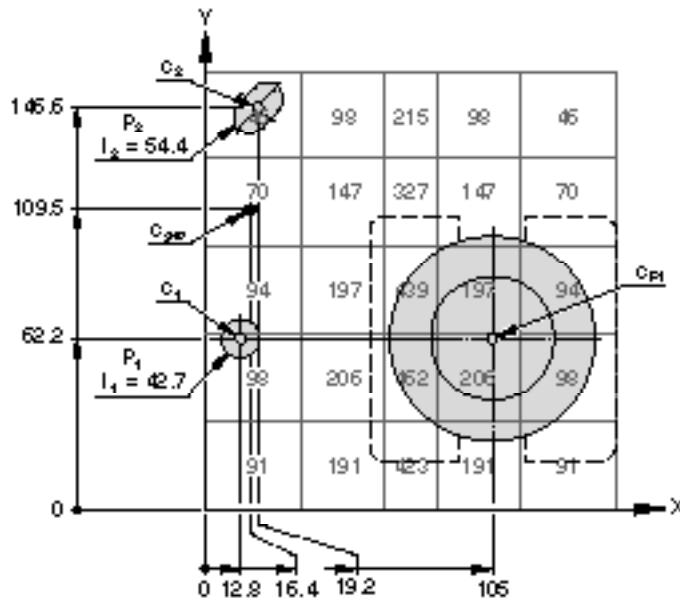

Figure 24: Eccentric hole pattern with compensation spring

ENGINEERING

LOAD-OPTIMISING MEASURES

With this arrangement, the proof of lifetime no longer produces inadmissible operating conditions:

$$F_{\text{Compensation}} < F_{\text{permissible}}$$

76.2 kN < 147 kN -> Loading by punch P₂ permissible

$$F_{S1} < F_{\text{permissible}}$$

24 kN < 206 kN -> The loading of the compensation spring after the end of the cutting process is permissible.

The solution must be coordinated with the die operator.

ENGINEERING

PROTRUSION BOX

Lateral protrusions beyond the cam unit work surface should generally be avoided - a wider cam unit is the better choice in these application cases. If a lateral protrusion can not be avoided for certain reasons, the following aspects must be ensured to guarantee the desired lifetime:

1. The total working force must not exceed the maximum permissible working force of the cam unit.
2. Asymmetrically arranged elements on the cam unit cause a shift of the centre of the force. The position of the centre of the force must be taken into account and adjusted with the permissible values according to the force diagram.
3. In the case of multiple hole operations on free-form surfaces, it is generally assumed that the hole punches enter the sheet at different times. Punches arranged eccentrically or in the protrusion of the cam work surface require a particularly precise design.

The tool length on cam units also has a significant influence on the system load and the working result of the cam unit. Long protrusions should be avoided whenever possible due to a weaker bending stiffness of the tools and a large lever effect.

ENGINEERING

PROTRUSION BOX

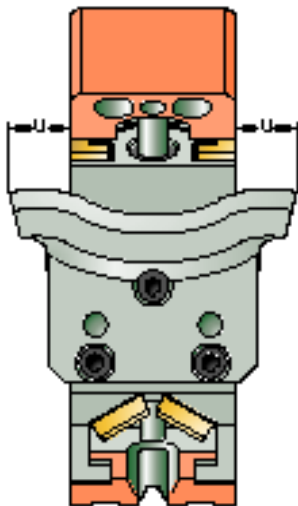
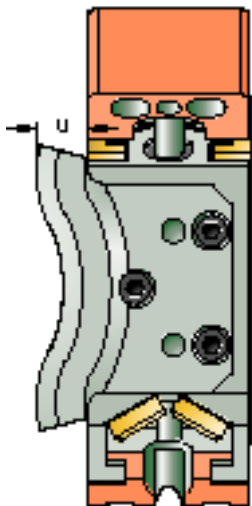
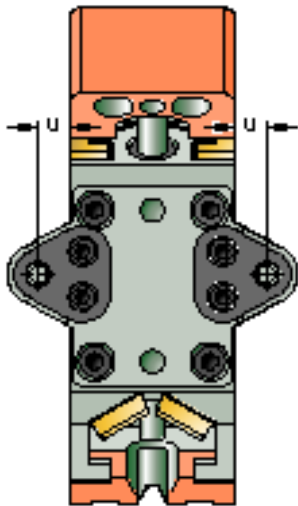
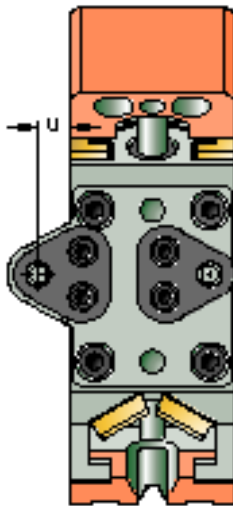
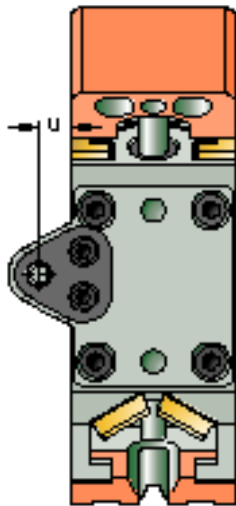
	unrestricted or partially permissible	not permitted
Cutting + forming	 <p>Figure 25: Trim steel, Protrusion centric</p>	 <p>Figure 27: Trim steel, Protrusion one-sided vertical</p>
Punching*	 <p>Figure 28: Hole pattern, Protrusion centric</p>	 <p>Figure 29: Hole pattern, Protrusion one-sided</p>
		 <p>Figure 30: Punch, Protrusion one-sided</p>
* Observe engagement point in time of the punches		

INTRODUCTION AND TABLE OF CONTENTS

ENGINEERING

2016.24. AERIAL FCC BAK

DAIMLER, VOLVO,
VOLKSWAGEN GROUP

2016.25. AERIAL FCC BAK

DAIMLER, VOLVO,
VOLKSWAGEN GROUP

2016.207. AERIAL ECO LINE

2016.208. AERIAL ECO LINE

CUSTOMER-SPECIFIC SERVICES

APPENDIX

EMERGENCY SITUATION / CONTACTS



AERIAL FCC 2016.24.



AERIAL FCC 2016.24.

The FIBRO cam unit FCC 2016.24. features compact dimensions, high forces in the working and return strokes as well as excellent precision, even after a high number of cycles.

All sliding elements are shouldered. The gas spring can be replaced, without having to remove the cam. Due to its design, the FIBRO cam unit series FCC meets the minimum maintenance requirements. The FIBRO cam unit FCC can be designed ex works with customer-specific tool-specific machining, which meets even the highest requirements of modern diemaking processes.

The FIBRO cam units FCC 2016.24. meet the requirements of the BAK product specification as well as the NAAMS.

Design features:

- Double prism guide
- Sliding surfaces hardened steel / bronze with solid lubricant
- Gas spring
- Positive locking connections

FIBRO cam units FCC 2016.24. are available in the widths from 60 to 600 mm and in the angular variants 0° to 75° (gradation 5°).

Order number	Width [mm]	Performance class [kN]*	Page
2016.24.006.□□.2000.00	60	125	57
2016.24.008.□□.1000.00	85	225	67
2016.24.011.□□.1000.00	110	350	77
2016.24.015.□□.1000.00	150	425	87
2016.24.018.□□.1000.00	180	500	97
2016.24.022.□□.1000.00	220	600	107
2016.24.026.□□.1000.00	260	650	117
2016.24.033.□□.2000.00	330	1000	127
2016.24.040.□□.2000.00	400	1050	137
2016.24.050.□□.2000.00	500	1150	147
2016.24.060.□□.2000.00	600	1200	157

* For exact power values, please refer to the force diagrams of the corresponding cam units

Ordering example:

FIBRO cam unit FCC, aerial, width 85 mm = 2016.24.008.□□.1000.00

Cam unit angle $\alpha = 50^\circ$ = 50.

Order number = 2016.24.008. 50. 1000.00



AERIAL FCC 2016.24.006.

Working width: 60 mm
Performance class: 125 kN

AERIAL FCC
2016.24.006.
 SIZE TABLE

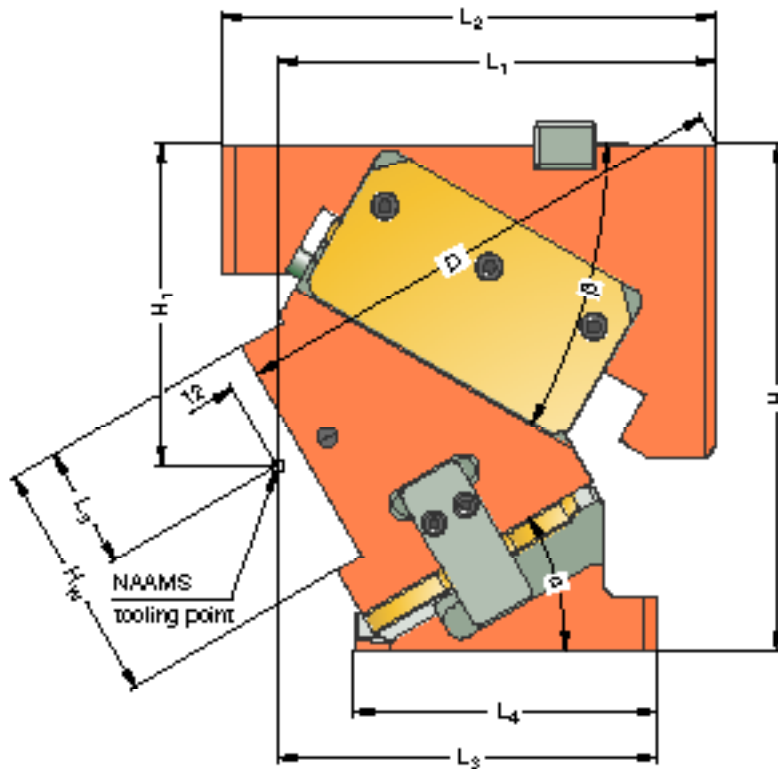
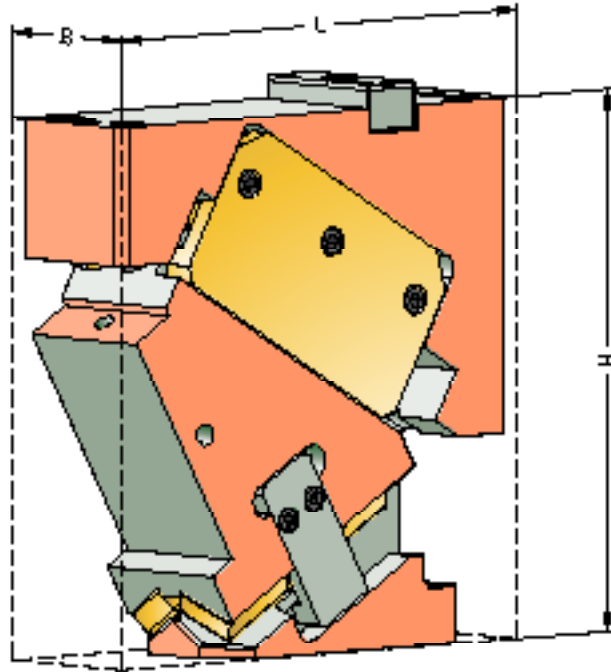

AERIAL FCC

2016.24.006.

SIZE TABLE

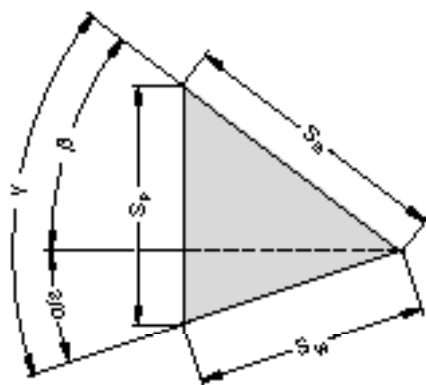

Order number	L [mm]	B [mm]	H [mm]	H ₁ [mm]	H _w [mm]	L ₁ [mm]	L ₂ [mm]	L ₃ [mm]	L ₄ [mm]	L ₅ [mm]	D [mm]	α [°]	β [°]	S _w * [mm]	S _s [mm]	S _p * [mm]
2016.24.006.00.2000.00	205	60	210	105.00	100	187.00	205	162.00	155	50	175.00	0	50	19.3	30	23.0
2016.24.006.05.2000.00	205	60	210	108.23	100	186.86	205	161.86	150	50	183.58	5	45	21.3	30	23.1
2016.24.006.10.2000.00	205	60	210	111.43	100	186.44	205	161.44	145	50	190.95	10	45	21.5	30	25.0
2016.24.006.15.2000.00	205	60	210	124.58	100	185.74	205	160.74	140	60	199.65	15	40	23.8	30	25.4
2016.24.006.20.2000.00	205	60	210	127.66	100	184.77	205	159.77	140	50	205.29	20	40	24.5	30	27.6
2016.24.006.25.2000.00	205	60	210	130.64	100	183.53	205	158.53	125	50	209.55	25	35	27.1	30	28.7
2016.24.006.30.2000.00	205	60	210	133.50	100	182.04	205	157.04	125	50	212.40	30	30	30.0	30	30.0
2016.24.006.35.2000.00	205	60	210	136.22	100	180.31	205	155.31	115	50	213.83	35	30	31.7	30	33.2
2016.24.006.40.2000.00	220	60	210	138.78	100	178.34	220	168.34	110	45	213.83	40	25	35.5	30	35.5
2016.24.006.45.2000.00	235	60	210	141.16	100	206.16	235	166.16	105	40	233.60	45	25	38.5	30	39.9
2016.24.006.50.2000.00	220	60	210	148.34	100	188.78	220	178.78	105	40	222.99	50	20	43.9	30	43.9
2016.24.006.55.2000.00	220	60	210	150.31	100	186.22	220	176.22	105	40	217.94	55	20	49.1	30	50.5
2016.24.006.60.2000.00	220	60	210	152.04	100	183.50	220	173.50	92	30	211.42	60	15	58.0	30	58.0
2016.24.006.65.2000.00	220	60	210	153.53	100	180.64	220	170.64	85	30	203.49	65	15	68.6	30	69.9
2016.24.006.70.2000.00	220	60	210	174.77	100	162.66	220	152.66	85	50	207.86	70	15	70.6	25	72.8
2016.24.006.75.2000.00	235	60	210	175.74	100	159.58	235	149.58	80	50	199.05	75	10	76.1	20	77.0

* Values rounded

Mounting cam base:

Hexagon socket head cap screws DIN EN ISO 4762
Dowel pins DIN EN ISO 8735

4x M12 / Strength class min. 8.8
2x Ø10

Mounting cam driver :

Hexagon socket head cap screws DIN EN ISO 4762
Dowel pins DIN EN ISO 8735

3x M10 / Strength class min. 8.8
2x Ø10

AERIAL FCC
2016.24.006.
EXPLODED VIEW

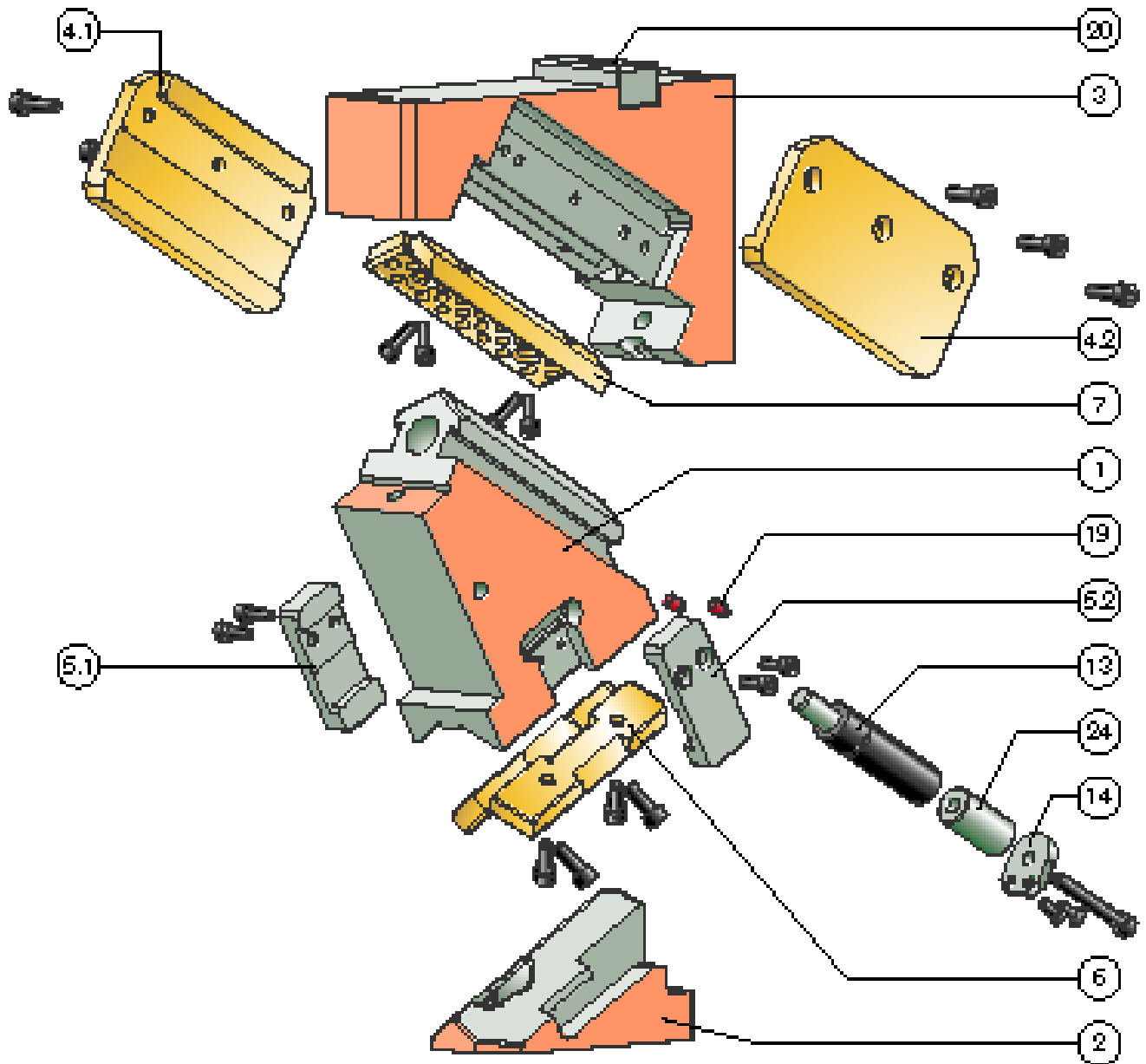

AERIAL FCC

2016.24.006.

PARTS LIST

Position	Piece	Designation	Material	spare part
1	1	Slider	1.7225	--
2	1	Cam driver	1.7225	--
2.1				
2.2				
3	1	Cam base	1.7225	--
4.1	1	Clamp, left	Bronze with solid lubricant	x
4.2	1	Clamp, right	Bronze with solid lubricant	x
5.1	1	Positive return, left	1.7225	x
5.2	1	Positive return, right	1.7225	x
6	2	Sliding plate	Bronze with solid lubricant	x
7	2	Sliding plate	Bronze with solid lubricant	x
8				
9				
10				
11				
12				
13	1	Gas spring	2487.12.00170.□□□	x
14	1	Stop plate	1.7225	x
15				
16.1				
16.2				
17				
18 (not shown)	1	Lockout system		x
19	2	Damping element	Elastomer	x
20	1	Feather key (T-nut)		x
21				
22				
23				
24	1	Spacer	1.1191	x

For inquiries or when ordering spare parts (x), we require the following data:

- ▶ Cam unit order no.
- ▶ Cam unit serial no.
- ▶ Item number / Designation / Spare part

AERIAL FCC

2016.24.006.

SYSTEM AND SURROUNDING FORCES

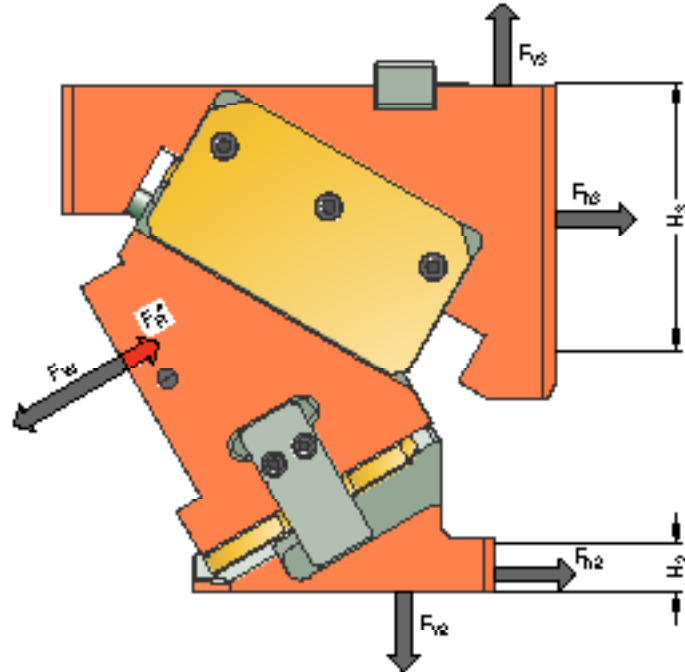

Order number	α [°]	F_W [kN]	F_R^* [kN]	F_{h2} [kN]	F_{v2} [kN]	F_{h3} [kN]	F_{v3} [kN]	H_2 [mm]	H_3 [mm]
2016.24.006.00.2000.00	0	136	2.6	0	114	136	114	22	150
2016.24.006.05.2000.00	5	137	2.7	10	115	126	126	22	140
2016.24.006.10.2000.00	10	138	2.9	17	95	119	119	22	140
2016.24.006.15.2000.00	15	139	3.0	25	94	109	130	22	130
2016.24.006.20.2000.00	20	140	3.3	28	76	104	124	22	120
2016.24.006.25.2000.00	25	141	3.4	34	74	93	133	22	120
2016.24.006.30.2000.00	30	142	3.4	41	71	82	142	22	110
2016.24.006.35.2000.00	35	143	3.9	38	55	79	137	22	110
2016.24.006.40.2000.00	40	143	4.0	43	51	67	143	40	100
2016.24.006.45.2000.00	45	143	4.7	37	37	64	138	22	100
2016.24.006.50.2000.00	50	142	4.8	40	33	52	142	22	90
2016.24.006.55.2000.00	55	142	6.0	31	22	50	138	22	90
2016.24.006.60.2000.00	60	142	6.0	33	19	38	142	22	80
2016.24.006.65.2000.00	65	142	8.2	23	11	37	139	22	80
2016.24.006.70.2000.00	70	141	12.0	12	4	37	137	70	70
2016.24.006.75.2000.00	75	141	11.4	12	3	25	139	70	70

* Retraction force values correspond to the spring-generated retraction force at the working point

The forces F_{h2} , F_{v2} as well as F_{h3} , F_{v3} act on the tool environment at maximum working force F_W .

AERIAL FCC

2016.24.006.

FORCE DIAGRAM

shouldered

		Width 60 mm		
		20	20	20
Height 100 mm	0°	20	20	20
	20	21	82	21
	20	28	109	28
	20	34	136	34
	20	27	109	27
	20	21	76	21

Support with feather key

		Width 60 mm		
		20	20	20
Height 100 mm	0°	20	20	20
	20	15	34	15
	20	20	35	20
	20	25	35	25
	20	20	35	20
	20	15	34	15

		Width 60 mm		
		20	20	20
Height 100 mm	5°	20	20	20
	20	23	84	23
	20	30	111	30
	20	37	137	37
	20	30	110	30
	20	23	83	23

		Width 60 mm		
		20	20	20
Height 100 mm	5°	20	20	20
	20	18	37	18
	20	22	40	22
	20	27	40	27
	20	22	40	22
	20	18	34	18

		Width 60 mm		
		20	20	20
Height 100 mm	10°	20	20	20
	20	25	85	25
	20	32	112	32
	20	40	138	40
	20	32	111	32
	20	25	84	25

		Width 60 mm		
		20	20	20
Height 100 mm	10°	20	20	20
	20	20	39	20
	20	22	41	22
	20	27	41	27
	20	22	41	22
	20	20	39	20

		Width 60 mm		
		20	20	20
Height 100 mm	15°	20	20	20
	20	27	87	27
	20	35	113	35
	20	43	139	43
	20	35	113	35
	20	27	85	27

		Width 60 mm		
		20	20	20
Height 100 mm	15°	20	20	20
	20	18	43	18
	20	24	45	24
	20	28	45	28
	20	24	45	24
	20	20	43	20

		Width 60 mm		
		20	20	20
Height 100 mm	20°	20	20	20
	20	29	88	29
	20	37	114	37
	20	46	140	46
	20	37	114	37
	20	29	87	29

		Width 60 mm		
		20	20	20
Height 100 mm	20°	20	20	20
	20	20	43	20
	20	25	50	25
	20	32	50	32
	20	26	50	26
	20	21	50	21

		Width 60 mm		
		20	20	20
Height 100 mm	25°	20	20	20
	20	31	90	31
	20	40	116	40
	20	49	141	49
	20	40	115	40
	20	31	88	31

		Width 60 mm		
		20	20	20
Height 100 mm	25°	20	20	20
	20	15	25	15
	20	23	55	23
	20	23	55	23
	20	23	55	23
	20	18	53	18

AERIAL FCC

2016.24.006.

FORCE DIAGRAM

shouldered

		Width 60 mm		
		20	20	20
Height 100 mm	20	33	91	33
	20	42	117	42
	20	52	142	52
	20	42	116	42
	20	33	89	33
	20			

Support with feather key

		Width 60 mm		
		20	20	20
Height 100 mm	20	20	60	20
	20	27	60	27
	20	30	62	30
	20	28	62	28
	20	24	60	24
	20			

35°

		Width 60 mm		
		20	20	20
Height 100 mm	20	35	93	35
	20	45	118	45
	20	54	143	54
	20	45	117	45
	20	35	91	35
	20			

35°

		Width 60 mm		
		20	20	20
Height 100 mm	20	16	60	16
	20	18	63	18
	20	20	64	20
	20	19	64	19
	20	17	61	17
	20			

40°

		Width 60 mm		
		20	20	20
Height 100 mm	20	34	89	34
	20	45	116	45
	20	56	143	56
	20	46	117	46
	20	35	91	35
	20			

40°

		Width 60 mm		
		20	20	20
Height 100 mm	20	15	54	15
	20	19	77	19
	20	19	77	19
	20	19	77	19
	20	17	69	17
	20			

45°

		Width 60 mm		
		20	20	20
Height 100 mm	20	33	84	33
	20	45	113	45
	20	57	143	57
	20	47	117	47
	20	36	90	36
	20			

45°

		Width 60 mm		
		20	20	20
Height 100 mm	20	10	27	10
	20	12	76	12
	20	13	80	13
	20	13	81	13
	20	12	67	12
	20			

50°

		Width 60 mm		
		20	20	20
Height 100 mm	20	32	80	32
	20	45	111	45
	20	58	142	58
	20	48	116	48
	20	37	90	37
	20			

50°

		Width 60 mm		
		20	20	20
Height 100 mm	20	14	32	14
	20	16	82	16
	20	16	95	16
	20	17	86	17
	20	15	66	15
	20			

55°

		Width 60 mm		
		20	20	20
Height 100 mm	20	31	75	31
	20	45	109	45
	20	60	142	60
	20	49	116	49
	20	37	90	37
	20			

55°

		Width 60 mm		
		20	20	20
Height 100 mm	20	10	13	10
	20	12	56	12
	20	13	105	13
	20	14	99	14
	20	13	76	13
	20			

AERIAL FCC

2016.24.006.

FORCE DIAGRAM

shouldered

		Width 60 mm		
		20	20	20
Height 100 mm	20	30	71	30
	20	45	106	45
	20	61	142	61
	20	50	115	50
	20	38	89	38

Support with feather key

		Width 60 mm		
		20	20	20
Height 100 mm	20	10	60	10
	20	12	91	12
	20	13	121	13
	20	14	98	14
	20	13	76	13

65°

		Width 60 mm		
		20	20	20
Height 100 mm	20	29	67	29
	20	45	104	45
	20	62	142	62
	20	51	115	51
	20	39	89	39

65°

		Width 60 mm		
		20	20	20
Height 100 mm	20	10	16	10
	20	12	50	12
	20	12	115	12
	20	12	110	12
	20	12	80	12

70°

		Width 60 mm		
		20	20	20
Height 100 mm	20	28	62	28
	20	46	102	46
	20	64	141	64
	20	52	115	52
	20	40	88	40

70°

		Width 60 mm		
		20	20	20
Height 100 mm	20	10	16	10
	20	12	45	12
	20	12	120	12
	20	12	115	12
	20	12	88	12

75°

		Width 60 mm		
		20	20	20
Height 100 mm	20	27	58	27
	20	46	100	46
	20	65	141	65
	20	53	114	53
	20	40	88	40

75°

		Width 60 mm		
		20	20	20
Height 100 mm	20	10	16	10
	20	12	38	12
	20	12	128	12
	20	12	114	12
	20	12	88	12

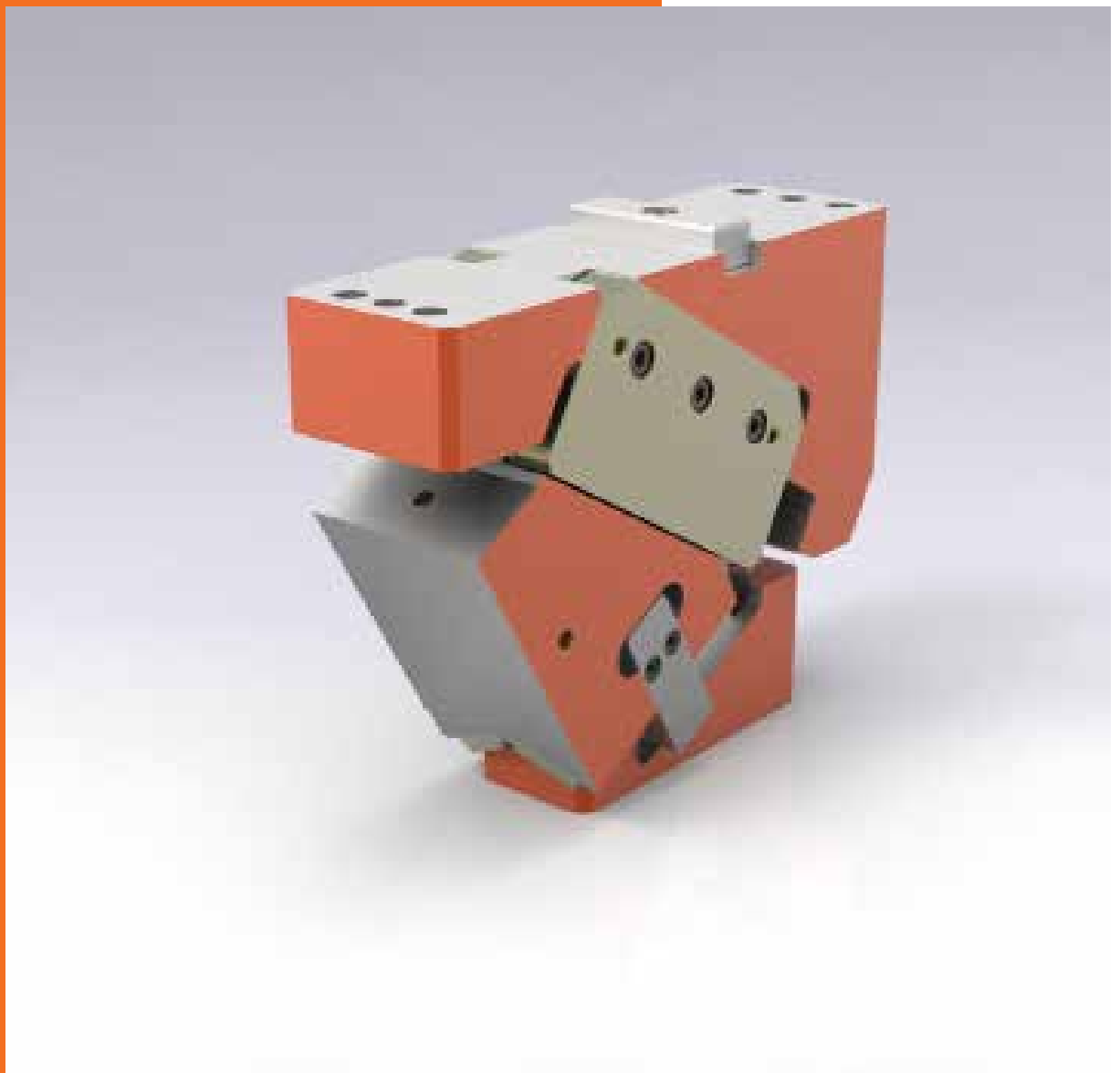

AERIAL FCC 2016.24.008.

Working width: 85 mm
Performance class: 225 kN

AERIAL FCC
2016.24.008.
 SIZE TABLE

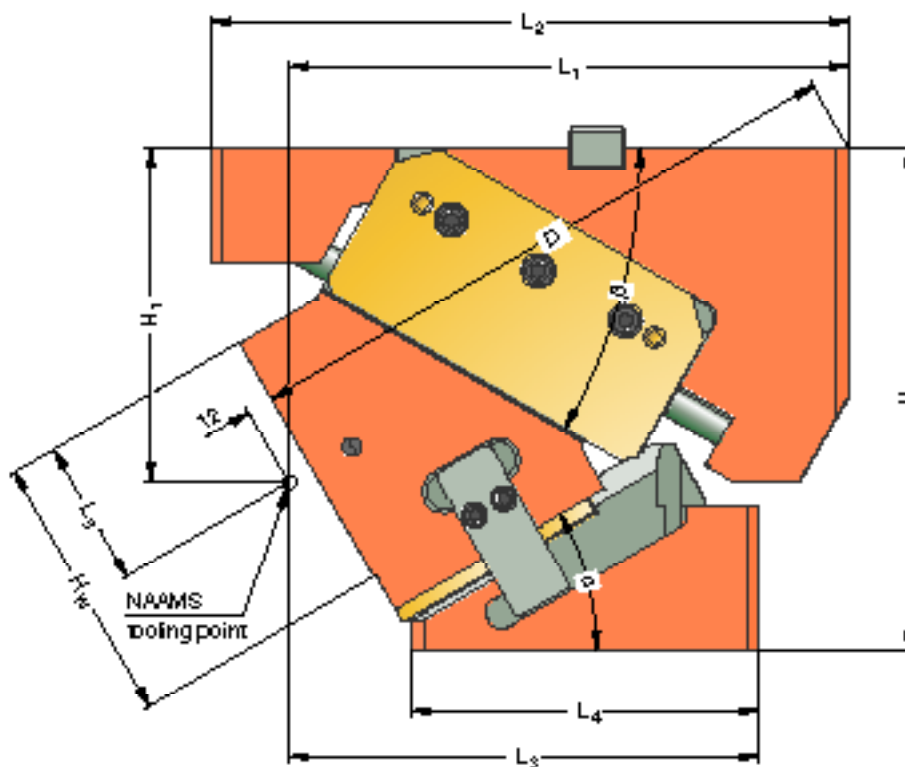
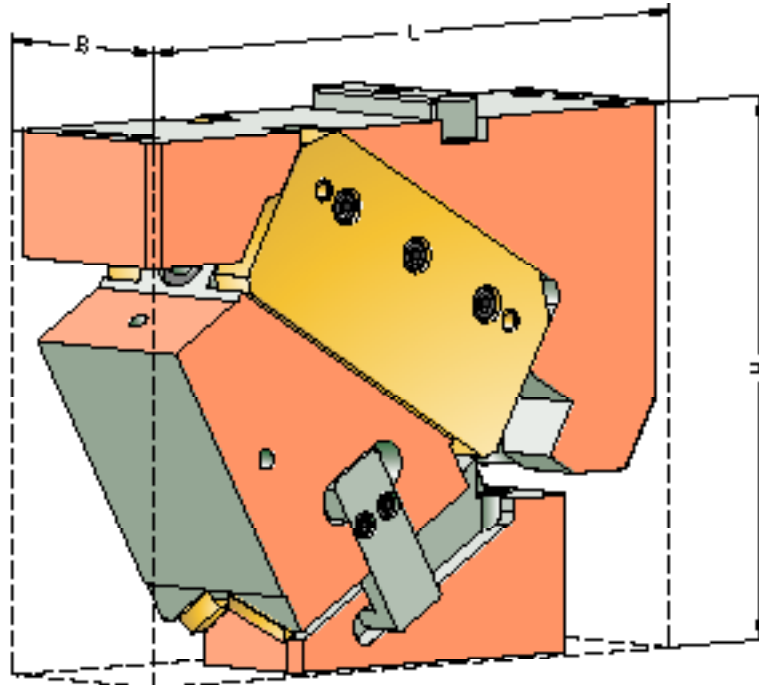

AERIAL FCC

2016.24.008.

SIZE TABLE

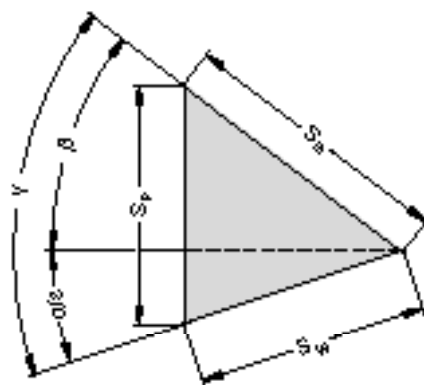

Order number	L [mm]	B [mm]	H [mm]	H ₁ [mm]	H _w [mm]	L ₁ [mm]	L ₂ [mm]	L ₃ [mm]	L ₄ [mm]	L ₅ [mm]	D [mm]	α [°]	β [°]	S _w * [mm]	S _s [mm]	S _p * [mm]
2016.24.008.00.1000.00	255	85	225	120	120	250	255	195	175	60	238.00	0	50	30.9	48	36.8
2016.24.008.05.1000.00	255	85	225	125	120	250	255	195	170	60	247.94	5	45	34.1	48	36.9
2016.24.008.10.1000.00	255	85	225	130	120	250	255	195	160	55	256.78	10	45	34.5	48	39.9
2016.24.008.15.1000.00	255	85	225	135	120	250	255	195	155	55	264.42	15	40	38.1	48	40.7
2016.24.008.20.1000.00	259	85	225	140	120	250	255	195	155	60	270.81	20	35	41.8	48	41.8
2016.24.008.25.1000.00	285	85	225	145	120	250	285	210	155	55	275.86	25	35	43.4	48	45.9
2016.24.008.30.1000.00	285	85	225	150	120	250	285	210	155	65	279.51	30	30	48.0	48	48.0
2016.24.008.35.1000.00	285	85	225	155	120	250	285	210	155	65	281.69	35	30	50.7	48	53.1
2016.24.008.40.1000.00	285	85	225	160	120	250	285	210	155	65	282.36	40	25	56.8	48	56.8
2016.24.008.45.1000.00	265	85	225	165	120	215	265	215	150	55	256.70	45	25	42.3	33	43.9
2016.24.008.50.1000.00	265	85	225	170	120	215	265	215	135	52	256.43	50	20	48.2	33	48.2
2016.24.008.55.1000.00	265	85	225	175	120	215	265	215	135	67	254.67	55	20	54.1	33	55.6
2016.24.008.60.1000.00	267	85	225	180	120	215	265	215	135	67	251.39	60	15	63.8	33	63.8
2016.24.008.65.1000.00	265	85	225	180	120	215	265	215	126	52	242.00	65	15	75.4	33	76.9
2016.24.008.70.1000.00	275	85	225	195	120	190	275	185	109	67	236.22	70	10	95.0	33	95.0
2016.24.008.75.1000.00	275	85	225	210	120	190	275	185	109	67	240.02	75	10	95.1	25	96.2

* Values rounded

Fastening cam base:

Hexagon socket head cap screws DIN EN ISO 4762
Dowel pins DIN EN ISO 8735

4x M12 / Strength class min. 8.8
2x Ø12

Fastening cam driver :

Hexagon socket head cap screws DIN EN ISO 4762
Dowel pins DIN EN ISO 8735

3x M12 / Strength class min. 8.8
2x Ø12

AERIAL FCC
2016.24.008.
EXPLODED VIEW

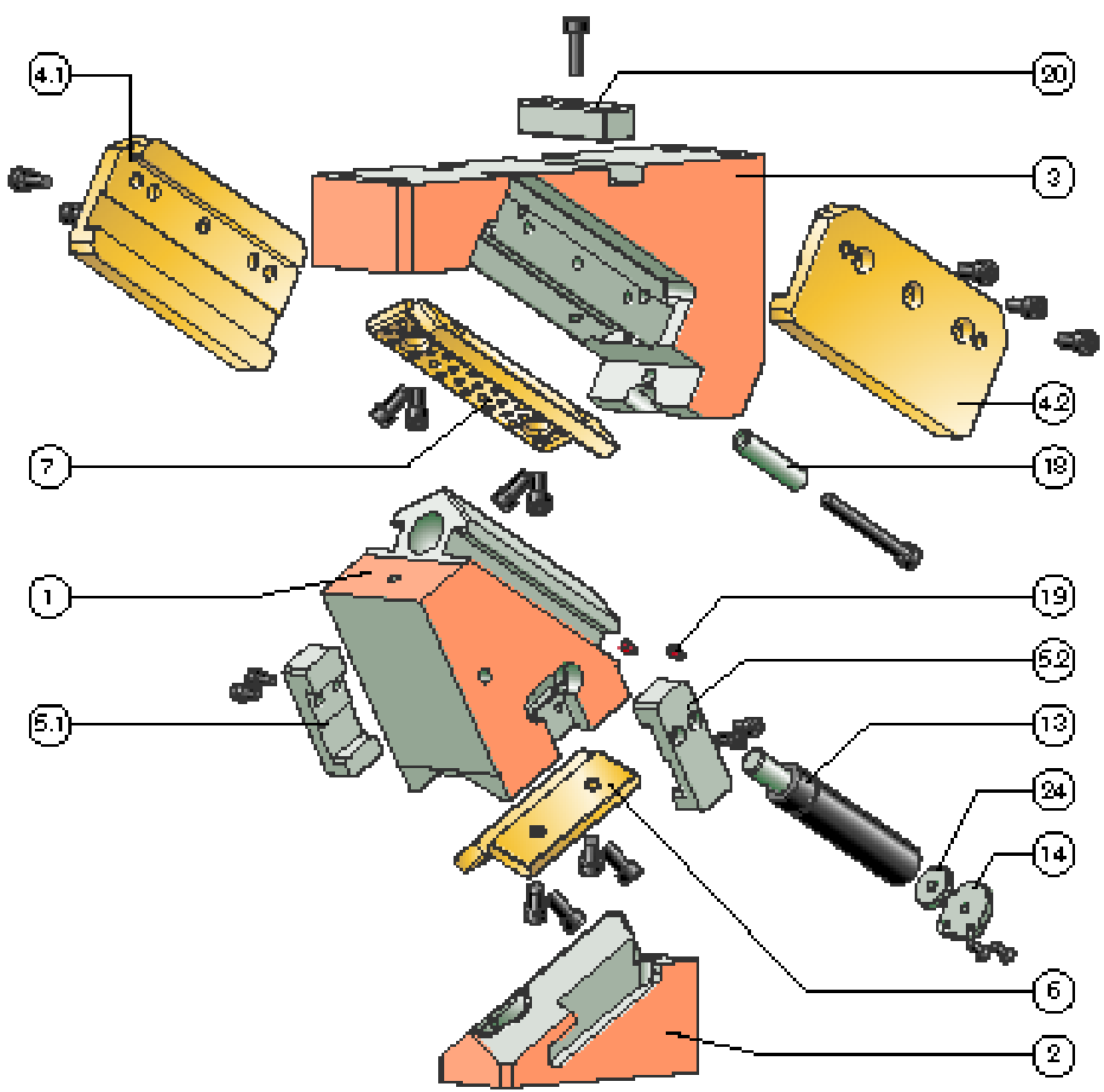

AERIAL FCC

2016.24.008.

PARTS LIST

Position	Piece	Designation	Material	spare part
1	1	Slider	1.7225	--
2	1	Cam driver	1.7225	--
2.1				
2.2				
3	1	Cam base	1.7225	--
4.1	1	Clamp, left	Bronze with solid lubricant	x
4.2	1	Clamp, right	Bronze with solid lubricant	x
5.1	1	Positive return, left	1.7225	x
5.2	1	Positive return, right	1.7225	x
6	2	Sliding plate	Bronze with solid lubricant	x
7	2	Sliding plate	Bronze with solid lubricant	x
8				
9				
10				
11				
12				
13	1	Gas spring	2487.12.00320.□□□	x
14	1	Stop plate	1.7225	x
15				
16.1				
16.2				
17				
18	1	Lockout system		x
19	2	Damping element	Elastomer	x
20	1	Feather key (T-nut)		x
21				
22				
23				
24	1	Spacer	1.1191	x

For inquiries or when ordering spare parts (x), we require the following data:

- ▶ Cam unit order no.
- ▶ Cam unit serial no.
- ▶ Item number / Designation / Spare part

AERIAL FCC

2016.24.008.

SYSTEM AND SURROUNDING FORCES

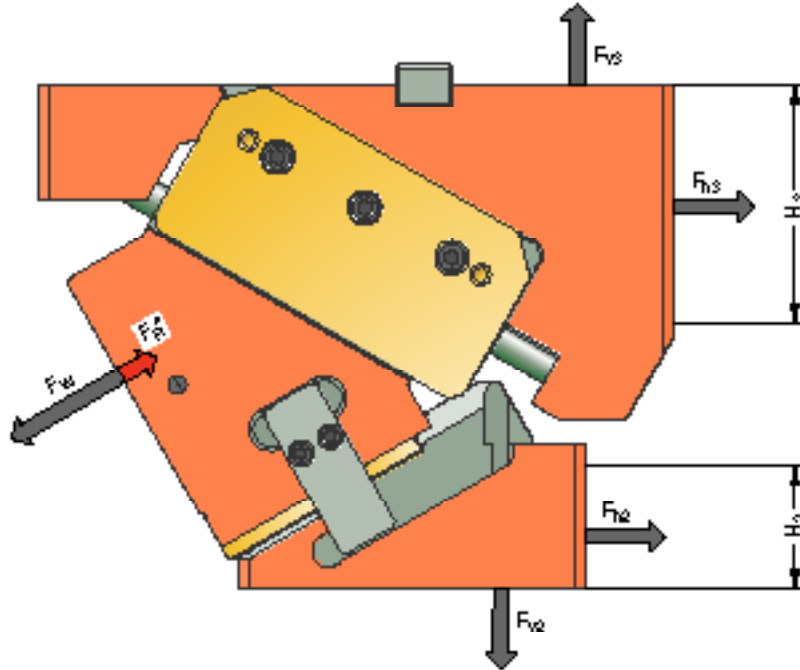

Order number	α [°]	F_w [kN]	F_{R^*} [kN]	F_{h2} [kN]	F_{v2} [kN]	F_{h3} [kN]	F_{v3} [kN]	H_2 [mm]	H_3 [mm]
2016.24.008.00.1000.00	0	230	5.1	0	230	193	193	25	150
2016.24.008.05.1000.00	5	230	5.2	17	212	192	212	25	140
2016.24.008.10.1000.00	10	230	5.7	28	199	159	199	25	140
2016.24.008.15.1000.00	15	230	5.7	42	180	156	215	25	120
2016.24.008.20.1000.00	20	230	5.7	55	161	151	230	25	120
2016.24.008.25.1000.00	25	229	6.4	56	152	120	217	25	120
2016.24.008.30.1000.00	30	229	6.4	66	132	115	229	40	110
2016.24.008.35.1000.00	35	229	7.4	61	126	87	219	40	110
2016.24.008.40.1000.00	40	237	7.8	71	111	85	237	50	85
2016.24.008.45.1000.00	45	245	8.3	63	110	63	236	50	95
2016.24.008.50.1000.00	50	253	8.4	71	92	59	253	50	70
2016.24.008.55.1000.00	55	261	10.5	57	92	40	254	50	70
2016.24.008.60.1000.00	60	269	10.5	62	72	36	269	50	55
2016.24.008.65.1000.00	65	277	14.2	44	73	21	272	70	55
2016.24.008.70.1000.00	70	285	14.3	47	50	17	285	85	70
2016.24.008.75.1000.00	75	293	20.9	25	51	7	290	100	70

* Retraction force values correspond to the spring-generated retraction force at the working point

The forces F_{h2} , F_{v2} as well as F_{h3} , F_{v3} act on the tool environment at maximum working force F_w .

AERIAL FCC

2016.24.008.

FORCE DIAGRAM

shouldered

		Width 85 mm		
		32.5	20	32.5
Height 120 mm	24	49	129	49
	24	69	180	69
	24	88	230	88
	24	63	165	63
	24	38	99	38

Support with feather key

		Width 85 mm		
		32.5	20	32.5
Height 120 mm	24	39	50	39
	24	45	56	45
	24	45	56	45
	24	45	56	45
	24	36	56	36

0°

		Width 85 mm		
		32.5	20	32.5
Height 120 mm	24	49	128	49
	24	68	179	68
	24	88	230	88
	24	63	166	63
	24	39	101	39

5°

		Width 85 mm		
		32.5	20	32.5
Height 120 mm	24	39	57	39
	24	43	62	43
	24	45	62	45
	24	45	62	45
	24	32	62	32

10°

		Width 85 mm		
		32.5	20	32.5
Height 120 mm	24	48	127	48
	24	68	178	68
	24	87	230	87
	24	63	167	63
	24	40	104	40

5°

		Width 85 mm		
		32.5	20	32.5
Height 120 mm	24	39	60	39
	24	39	62	39
	24	45	62	45
	24	45	62	45
	24	35	62	35

15°

		Width 85 mm		
		32.5	20	32.5
Height 120 mm	24	47	126	47
	24	67	178	67
	24	87	230	87
	24	64	168	64
	24	40	106	40

10°

		Width 85 mm		
		32.5	20	32.5
Height 120 mm	24	35	72	35
	24	48	74	48
	24	53	74	53
	24	54	74	54
	24	36	74	36

20°

		Width 85 mm		
		32.5	20	32.5
Height 120 mm	24	47	125	47
	24	67	177	67
	24	86	230	86
	24	64	170	64
	24	41	108	41

15°

		Width 85 mm		
		32.5	20	32.5
Height 120 mm	24	32	76	32
	24	48	78	48
	24	54	78	54
	24	54	78	54
	24	37	76	37

25°

		Width 85 mm		
		32.5	20	32.5
Height 120 mm	24	46	123	46
	24	66	176	66
	24	86	229	86
	24	64	171	64
	24	42	111	42

20°

		Width 85 mm		
		32.5	20	32.5
Height 120 mm	24	28	80	28
	24	40	85	40
	24	56	85	56
	24	49	85	49
	24	38	85	38

AERIAL FCC

2016.24.008.

FORCE DIAGRAM

shouldered

		Width 85 mm		
		32.5	20	32.5
Height 120 mm	24	46	122	46
	24	66	176	66
	24	85	229	85
	24	64	172	64
	24	43	113	43

Support with feather key

		Width 85 mm		
		32.5	20	32.5
Height 120 mm	24	27	72	27
	24	39	84	39
	24	51	90	51
	24	42	90	42
	24	38	86	38

35°

		Width 85 mm		
		32.5	20	32.5
Height 120 mm	24	45	121	45
	24	65	175	65
	24	85	229	85
	24	64	173	64
	24	44	118	44

35°

		Width 85 mm		
		32.5	20	32.5
Height 120 mm	24	27	74	27
	24	39	95	39
	24	51	95	51
	24	39	95	39
	24	39	88	39

40°

		Width 85 mm		
		32.5	20	32.5
Height 120 mm	24	43	119	43
	24	63	178	63
	24	84	237	84
	24	63	178	63
	24	42	119	42

40°

		Width 85 mm		
		32.5	20	32.5
Height 120 mm	24	27	78	27
	24	43	113	43
	24	72	108	72
	24	56	108	56
	24	38	105	38

45°

		Width 85 mm		
		32.5	20	32.5
Height 120 mm	24	40	116	40
	24	61	181	61
	24	82	245	82
	24	62	183	62
	24	41	121	41

45°

		Width 85 mm		
		32.5	20	32.5
Height 120 mm	24	25	78	25
	24	43	118	43
	24	74	123	74
	24	55	108	55
	24	40	105	40

50°

		Width 85 mm		
		32.5	20	32.5
Height 120 mm	24	38	114	38
	24	60	183	60
	24	81	253	81
	24	61	188	61
	24	40	123	40

50°

		Width 85 mm		
		32.5	20	32.5
Height 120 mm	24	24	84	24
	24	53	135	53
	24	73	145	73
	24	55	139	55
	24	39	115	39

55°

		Width 85 mm		
		32.5	20	32.5
Height 120 mm	24	38	114	38
	24	60	183	60
	24	81	253	81
	24	61	188	61
	24	40	123	40

55°

		Width 85 mm		
		32.5	20	32.5
Height 120 mm	24	22	94	22
	24	42	141	42
	24	73	174	73
	24	54	172	54
	24	38	125	38

AERIAL FCC

2016.24.008.

FORCE DIAGRAM

shouldered

		Width 85 mm		
		32.5	20	32.5
Height 120 mm	24	33	108	33
	24	56	189	56
	24	79	269	79
	24	58	198	58
	24	37	126	37

Support with feather key

		Width 85 mm		
		32.5	20	32.5
Height 120 mm	24	21	92	21
	24	35	143	35
	24	50	197	50
	24	42	175	42
	24	31	126	31

65°

		Width 85 mm		
		32.5	20	32.5
Height 120 mm	24	31	106	31
	24	54	192	54
	24	77	277	77
	24	57	203	57
	24	36	128	36

65°

		Width 85 mm		
		32.5	20	32.5
Height 120 mm	24	20	98	20
	24	36	178	36
	24	52	203	52
	24	43	189	43
	24	32	119	32

70°

		Width 85 mm		
		32.5	20	32.5
Height 120 mm	24	28	103	28
	24	52	194	52
	24	76	285	76
	24	56	208	56
	24	35	130	35

70°

		Width 85 mm		
		32.5	20	32.5
Height 120 mm	24	19	103	19
	24	35	194	35
	24	51	205	51
	24	37	192	37
	24	23	130	23

75°

		Width 85 mm		
		32.5	20	32.5
Height 120 mm	24	26	101	26
	24	50	197	50
	24	75	293	75
	24	54	212	54
	24	34	132	34

75°

		Width 85 mm		
		32.5	20	32.5
Height 120 mm	24	17	101	17
	24	34	197	34
	24	50	225	50
	24	36	225	36
	24	22	132	22

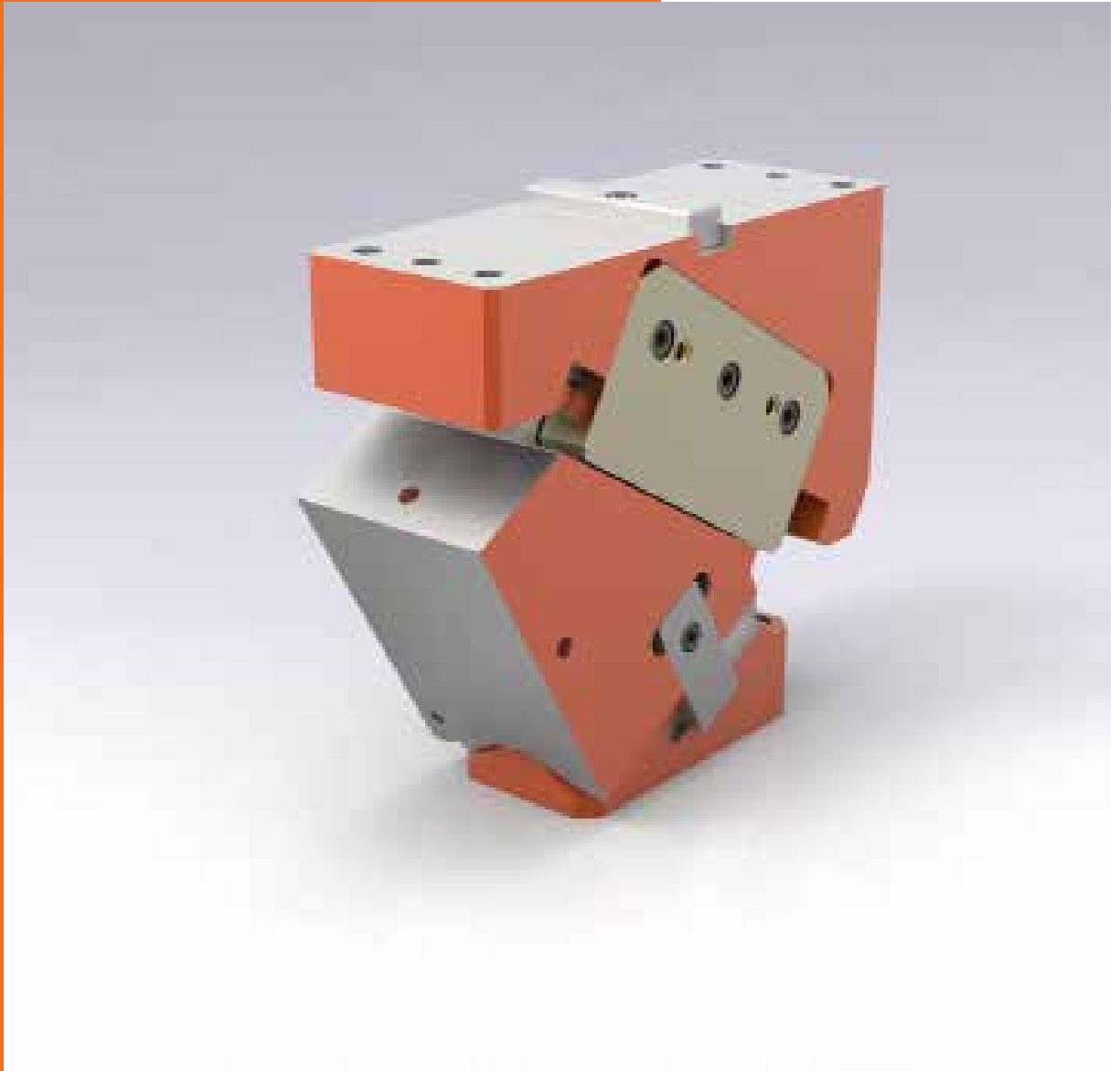

AERIAL FCC 2016.24.011.

Working width: 110 mm
Performance class: 350 kN

AERIAL FCC
2016.24.011.
 SIZE TABLE

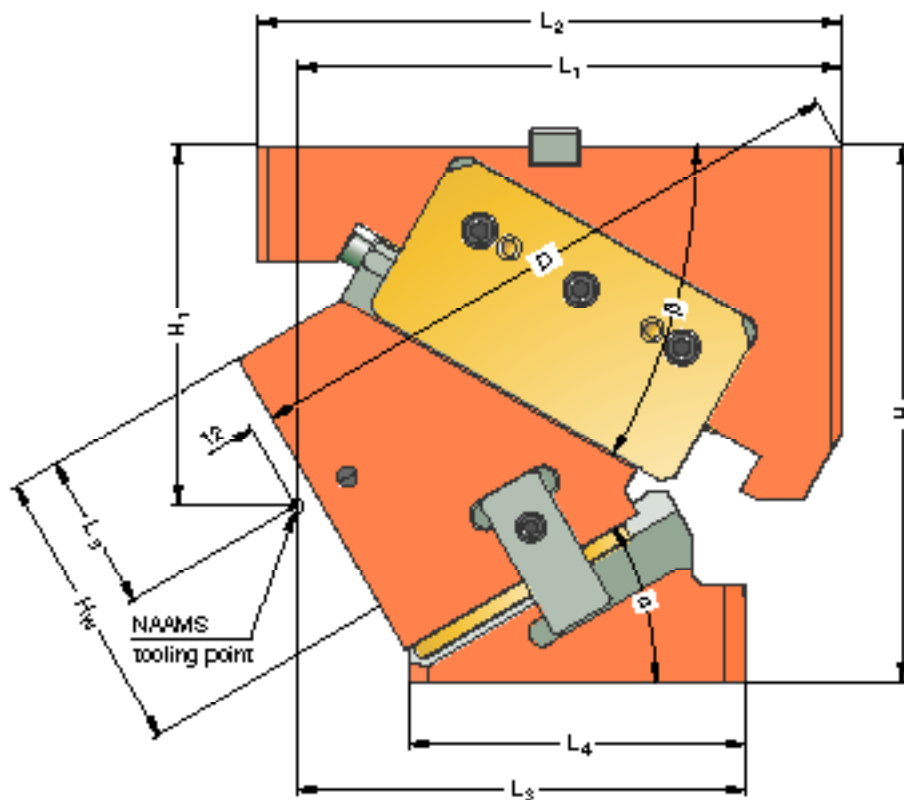
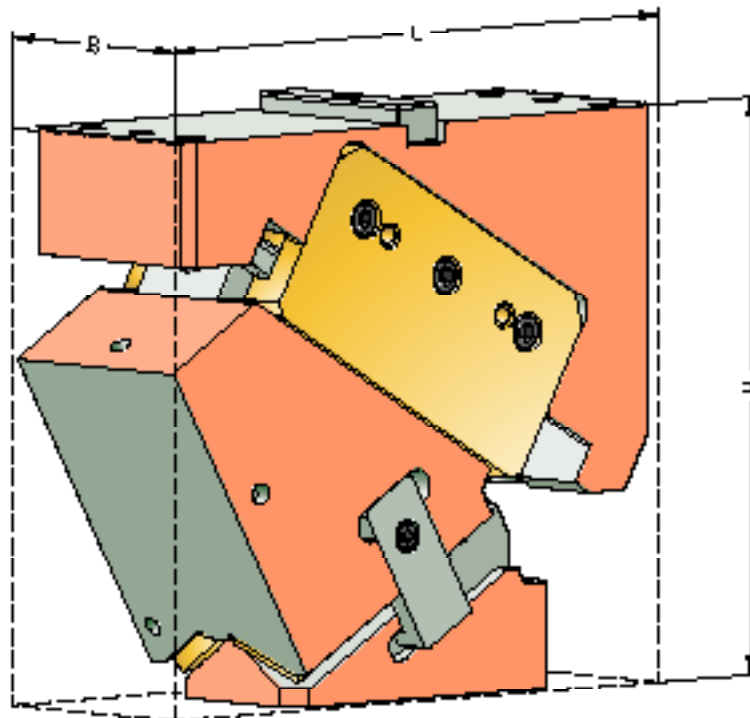

AERIAL FCC

2016.24.011.

SIZE TABLE

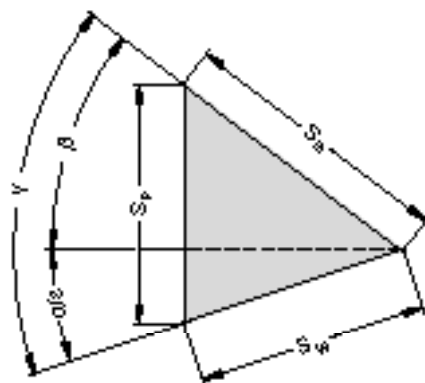

Order number	L [mm]	B [mm]	H [mm]	H ₁ [mm]	H _w [mm]	L ₁ [mm]	L ₂ [mm]	L ₃ [mm]	L ₄ [mm]	L ₅ [mm]	D [mm]	α [°]	β [°]	S _w * [mm]	S _s [mm]	S _p * [mm]
2016.24.011.00.1000.00	290	110	275	155	160	290	290	230	210	85	278.0	0	50	30.9	48	36.8
2016.24.011.05.1000.00	290	110	275	160	160	290	290	230	205	85	290.8	5	45	34.1	48	36.9
2016.24.011.10.1000.00	293	110	275	165	160	290	290	230	195	85	302.2	10	45	34.5	48	39.9
2016.24.011.15.1000.00	300	110	275	170	160	290	290	230	190	85	312.1	15	40	38.1	48	40.7
2016.24.011.20.1000.00	308	110	275	175	160	290	290	230	185	85	320.4	20	35	41.8	48	41.8
2016.24.011.25.1000.00	303	110	275	180	160	280	300	230	178	80	317.8	25	35	43.4	48	45.9
2016.24.011.30.1000.00	310	110	275	185	160	280	300	230	172	80	323.0	30	30	48.0	48	48.0
2016.24.011.35.1000.00	316	110	275	190	160	280	300	230	167	80	326.3	35	30	50.7	48	53.1
2016.24.011.40.1000.00	322	110	275	195	160	280	300	230	163	80	327.8	40	25	56.8	48	56.8
2016.24.011.45.1000.00	312	110	275	200	160	260	295	250	183	85	313.3	45	25	61.5	48	63.8
2016.24.011.50.1000.00	310	110	275	205	160	260	295	250	172	75	312.2	50	20	48.2	33	48.2
2016.24.011.55.1000.00	302	110	275	210	160	260	295	250	157	60	309.2	55	20	54.1	33	55.6
2016.24.011.60.1000.00	306	110	275	215	160	260	295	250	155	60	304.2	60	15	63.8	33	63.8
2016.24.011.65.1000.00	295	110	275	225	160	250	295	250	137	45	297.6	65	15	75.4	33	76.9
2016.24.011.70.1000.00	295	110	275	235	160	250	295	250	135	45	294.3	70	10	95.0	33	95.0
2016.24.011.75.1000.00	310	110	275	235	160	250	310	250	134	45	279.7	75	10	95.1	25	96.2

* Values rounded

Fastening cam base:

Hexagon socket head cap screws DIN EN ISO 4762
Dowel pins DIN EN ISO 8735

4x M12 / Strength class min. 8.8
2x Ø12

Fastening cam driver :

Hexagon socket head cap screws DIN EN ISO 4762
Dowel pins DIN EN ISO 8735

4x M12 / Strength class min. 8.8
2x Ø12

AERIAL FCC
2016.24.011.
 EXPLODED VIEW

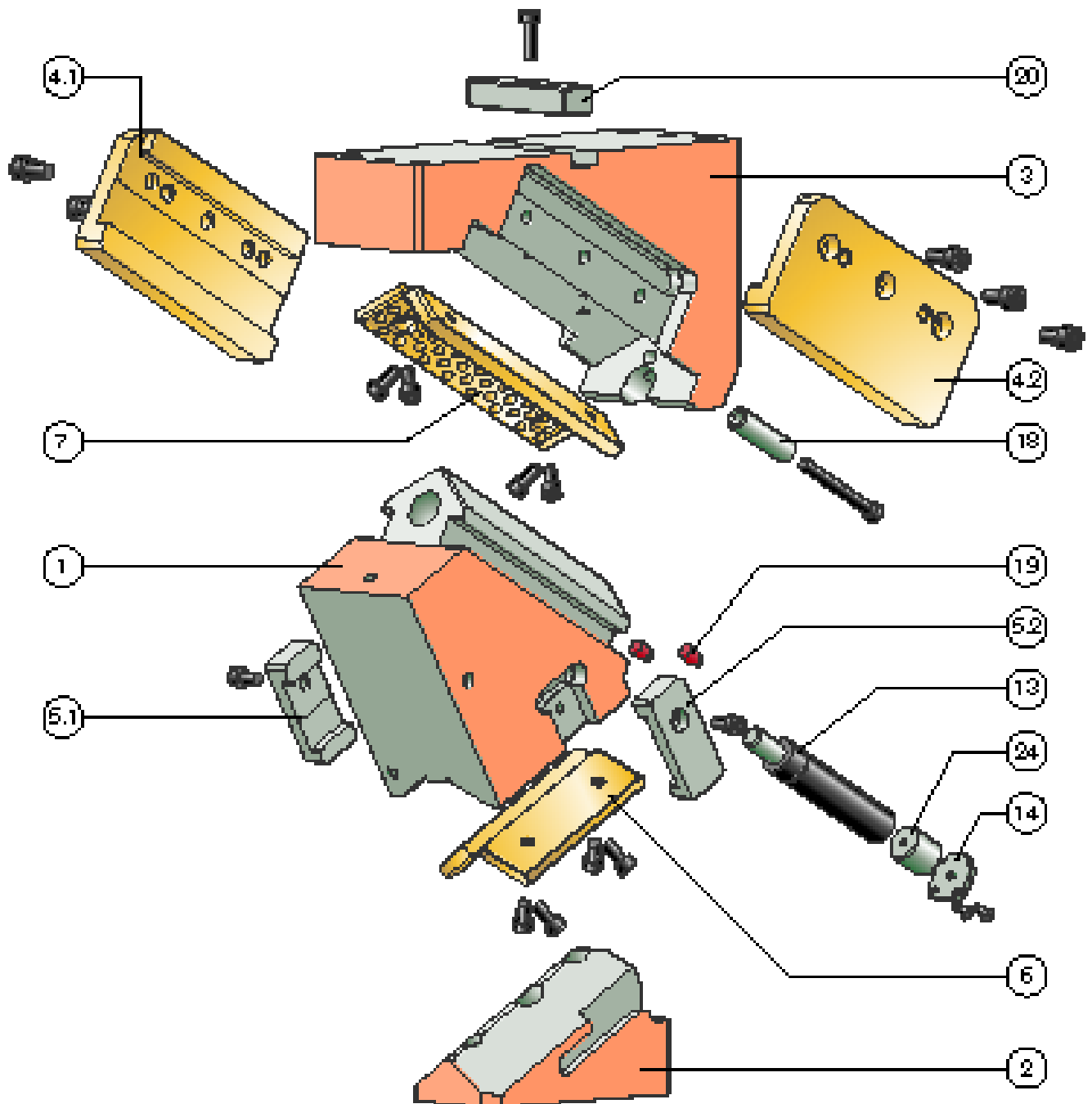

AERIAL FCC

2016.24.011.

PARTS LIST

Position	Piece	Designation	Material	spare part
1	1	Slider	1.7225	--
2	1	Cam driver	1.7225	--
2.1				
2.2				
3	1	Cam base	1.7225	--
4.1	1	Clamp, left	Bronze with solid lubricant	x
4.2	1	Clamp, right	Bronze with solid lubricant	x
5.1	1	Positive return, left	1.7225	x
5.2	1	Positive return, right	1.7225	x
6	2	Sliding plate	Bronze with solid lubricant	x
7	2	Sliding plate	Bronze with solid lubricant	x
8				
9				
10				
11				
12				
13	1	Gas spring	2487.12.00320.□□□	x
14	1	Stop plate	1.7225	x
15				
16.1				
16.2				
17				
18	1	Lockout system		x
19	2	Damping element	Elastomer	x
20	1	Feather key (T-nut)		x
21				
22				
23				
24	1	Spacer	1.1191	x

For inquiries or when ordering spare parts (x), we require the following data:

- ▶ Cam unit order no.
- ▶ Cam unit serial no.
- ▶ Item number / Designation / Spare part

AERIAL FCC

2016.24.011.

SYSTEM AND SURROUNDING FORCES

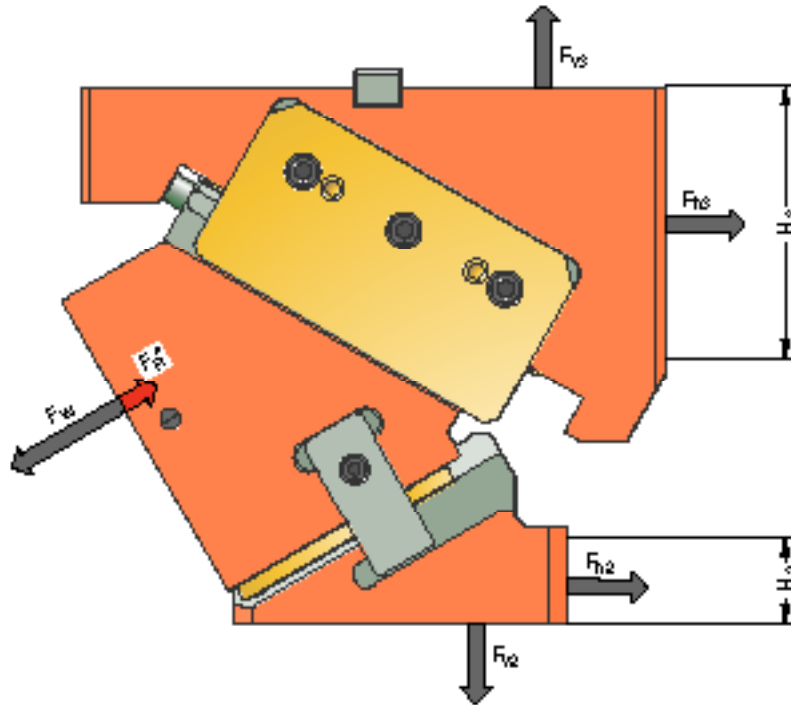

Order number	α [°]	F_W [kN]	F_R^* [kN]	F_{h2} [kN]	F_{v2} [kN]	F_{h3} [kN]	F_{v3} [kN]	H_2 [mm]	H_3 [mm]
2016.24.011.00.1000.00	0	375	5.2	0	315	375	315	25	160
2016.24.011.05.1000.00	5	355	5.3	26	297	328	328	25	150
2016.24.011.10.1000.00	10	359	5.8	44	248	310	310	25	150
2016.24.011.15.1000.00	15	372	5.8	67	252	292	348	30	140
2016.24.011.20.1000.00	20	375	5.8	90	247	263	375	30	130
2016.24.011.25.1000.00	25	378	6.5	92	198	250	358	30	130
2016.24.011.30.1000.00	30	381	6.5	110	191	220	381	40	120
2016.24.011.35.1000.00	35	384	7.5	103	147	212	367	40	120
2016.24.011.40.1000.00	40	387	7.5	116	138	180	387	40	100
2016.24.011.45.1000.00	45	390	9.0	100	100	175	376	50	100
2016.24.011.50.1000.00	50	393	8.2	110	92	143	393	50	100
2016.24.011.55.1000.00	55	396	10.2	87	61	140	385	65	100
2016.24.011.60.1000.00	60	399	10.2	93	53	107	399	75	100
2016.24.011.65.1000.00	65	402	13.8	64	30	106	394	80	90
2016.24.011.70.1000.00	70	405	13.8	67	24	71	405	85	82
2016.24.011.75.1000.00	75	407	21.0	34	9	71	402	90	56

* Retraction force values correspond to the spring-generated retraction force at the working point

The forces F_{h2} , F_{v2} as well as F_{h3} , F_{v3} act on the tool environment at maximum working force F_W .

AERIAL FCC

2016.24.011.

FORCE DIAGRAM

shouldered

Support with feather key

		Width 110 mm				
		25	20	20	20	25
0°		59	95	226	95	59
Height 160 mm	32	76	123	292	123	76
	32	93	150	357	150	93
	32	85	137	326	137	85
	32	76	124	294	124	76
	32					

		Width 110 mm				
		25	20	20	20	25
0°		35	57	70	57	35
Height 160 mm	32	45	57	73	57	45
	32	56	57	73	57	56
	32	51	57	73	57	51
	32	46	57	73	57	46
	32					

		Width 110 mm				
		25	20	20	20	25
5°		55	92	225	92	55
Height 160 mm	32	74	123	305	123	74
	32	92	155	366	155	92
	32	82	137	334	137	82
	32	72	120	294	120	72
	32					

		Width 110 mm				
		25	20	20	20	25
5°		33	55	79	55	33
Height 160 mm	32	44	58	82	58	44
	32	55	60	82	60	55
	32	49	60	82	60	49
	32	43	58	82	58	43
	32					

		Width 110 mm				
		25	20	20	20	25
10°		52	88	224	88	52
Height 160 mm	32	72	124	316	124	72
	32	91	159	369	159	91
	32	79	138	337	138	79
	32	68	116	294	116	68
	32					

		Width 110 mm				
		25	20	20	20	25
10°		31	53	82	53	31
Height 160 mm	32	43	74	85	74	43
	32	55	83	86	83	55
	32	48	83	86	83	48
	32	41	69	84	69	41
	32					

		Width 110 mm				
		25	20	20	20	25
15°		48	85	223	85	48
Height 160 mm	32	69	125	322	125	69
	32	91	164	372	164	91
	32	77	138	340	138	77
	32	63	112	293	112	63
	32					

		Width 110 mm				
		25	20	20	20	25
15°		29	51	92	51	29
Height 160 mm	32	42	75	92	75	42
	32	54	83	93	83	54
	32	46	83	93	83	46
	32	38	67	92	67	38
	32					

		Width 110 mm				
		25	20	20	20	25
20°		45	82	222	82	45
Height 160 mm	32	67	125	328	125	67
	32	90	168	375	168	90
	32	74	138	343	138	74
	32	59	108	293	108	59
	32					

		Width 110 mm				
		25	20	20	20	25
20°		27	49	97	49	27
Height 160 mm	32	40	75	103	75	40
	32	54	83	103	83	54
	32	45	83	103	83	45
	32	35	65	103	65	35
	32					

		Width 110 mm				
		25	20	20	20	25
25°		41	78	221	78	41
Height 160 mm	32	65	126	334	126	65
	32	89	173	378	173	89
	32	72	138	345	138	72
	32	55	104	293	104	55
	32					

		Width 110 mm				
		25	20	20	20	25
25°		25	47	98	47	25
Height 160 mm	32	39	75	110	75	39
	32	53	83	115	83	53
	32	43	83	115	83	43
	32	33	62	112	62	33
	32					

AERIAL FCC

2016.24.011.

FORCE DIAGRAM

shouldered

		Width 110 mm				
		25	20	20	20	25
Height 160 mm	32	38	75	220	75	38
	32	63	126	340	126	63
	32	88	177	381	177	88
	32	69	139	348	139	69
	32	50	100	293	100	50

		Width 110 mm				
		25	20	20	20	25
Height 160 mm	32	35	72	219	72	35
	32	61	127	346	127	61
	32	87	182	384	182	87
	32	67	139	351	139	67
	32	46	96	293	96	46

		Width 110 mm				
		25	20	20	20	25
Height 160 mm	32	34	72	226	72	34
	32	60	126	344	126	60
	32	86	181	387	181	86
	32	65	136	352	136	65
	32	44	91	283	91	44

		Width 110 mm				
		25	20	20	20	25
Height 160 mm	32	34	72	232	72	34
	32	59	126	342	126	59
	32	85	180	390	180	85
	32	63	133	353	133	63
	32	41	87	274	87	41

		Width 110 mm				
		25	20	20	20	25
Height 160 mm	32	34	72	239	72	34
	32	59	126	340	126	59
	32	84	179	393	179	84
	32	61	130	354	130	61
	32	39	82	264	82	39

		Width 110 mm				
		25	20	20	20	25
Height 160 mm	32	34	73	245	73	34
	32	58	125	338	125	58
	32	82	178	396	178	82
	32	59	128	356	128	59
	32	36	77	255	77	36

Support with feather key

		Width 110 mm				
		25	20	20	20	25
Height 160 mm	32	23	45	100	45	23
	32	38	76	120	76	38
	32	53	83	125	83	53
	32	42	83	125	83	42
	32	30	60	125	60	30

		Width 110 mm				
		25	20	20	20	25
Height 160 mm	32	21	43	105	43	21
	32	37	76	126	76	37
	32	52	93	127	93	52
	32	40	83	127	83	40
	32	28	58	126	58	28

		Width 110 mm				
		25	20	20	20	25
Height 160 mm	32	22	56	135	56	22
	32	38	80	142	80	38
	32	54	114	156	114	54
	32	41	86	154	86	41
	32	28	58	150	58	28

		Width 110 mm				
		25	20	20	20	25
Height 160 mm	32	22	46	148	46	22
	32	38	80	151	80	38
	32	54	114	165	114	54
	32	40	84	165	84	40
	32	26	55	140	55	26

		Width 110 mm				
		25	20	20	20	25
Height 160 mm	32	21	46	149	46	21
	32	37	79	167	79	37
	32	53	113	190	113	53
	32	39	82	189	82	39
	32	24	52	150	52	24

		Width 110 mm				
		25	20	20	20	25
Height 160 mm	32	21	46	153	46	21
	32	37	79	170	79	37
	32	52	112	193	112	52
	32	37	81	193	81	37
	32	23	49	159	49	23

AERIAL FCC

2016.24.011.

FORCE DIAGRAM

shouldered

		Width 110 mm				
		25	20	20	20	25
Height 160 mm	32	33	73	252	73	33
	32	57	125	336	125	57
	32	81	177	399	177	81
	32	57	125	357	125	57
	32	34	73	246	73	34

Support with feather key

		Width 110 mm				
		25	20	20	20	25
Height 160 mm	32	21	46	161	46	21
	32	36	79	172	79	36
	32	51	112	253	112	51
	32	36	79	253	79	36
	32	21	46	168	46	21

65°

		Width 110 mm				
		25	20	20	20	25
Height 160 mm	32	33	73	259	73	33
	32	56	124	335	124	56
	32	80	176	402	176	80
	32	55	122	358	122	55
	32	31	68	236	68	31

65°

		Width 110 mm				
		25	20	20	20	25
Height 160 mm	32	22	49	169	49	22
	32	38	83	175	83	38
	32	53	117	270	117	53
	32	37	81	270	81	37
	32	21	45	170	45	21

70°

		Width 110 mm				
		25	20	20	20	25
Height 160 mm	32	33	73	261	73	33
	32	56	124	333	124	56
	32	78	174	405	174	78
	32	54	119	359	119	54
	32	29	64	227	64	29

70°

		Width 110 mm				
		25	20	20	20	25
Height 160 mm	32	22	49	170	49	22
	32	37	83	176	83	37
	32	52	90	273	90	52
	32	36	79	263	79	36
	32	19	42	173	42	19

75°

		Width 110 mm				
		25	20	20	20	25
Height 160 mm	32	55	123	331	123	55
	32	77	173	407	173	77
	32	52	116	360	116	52
	32	26	59	218	59	26
	32	41	87	274	87	41

75°

		Width 110 mm				
		25	20	20	20	25
Height 160 mm	32	22	49	255	49	22
	32	37	82	331	82	37
	32	51	90	370	90	51
	32	34	77	360	77	34
	32	17	39	218	39	17

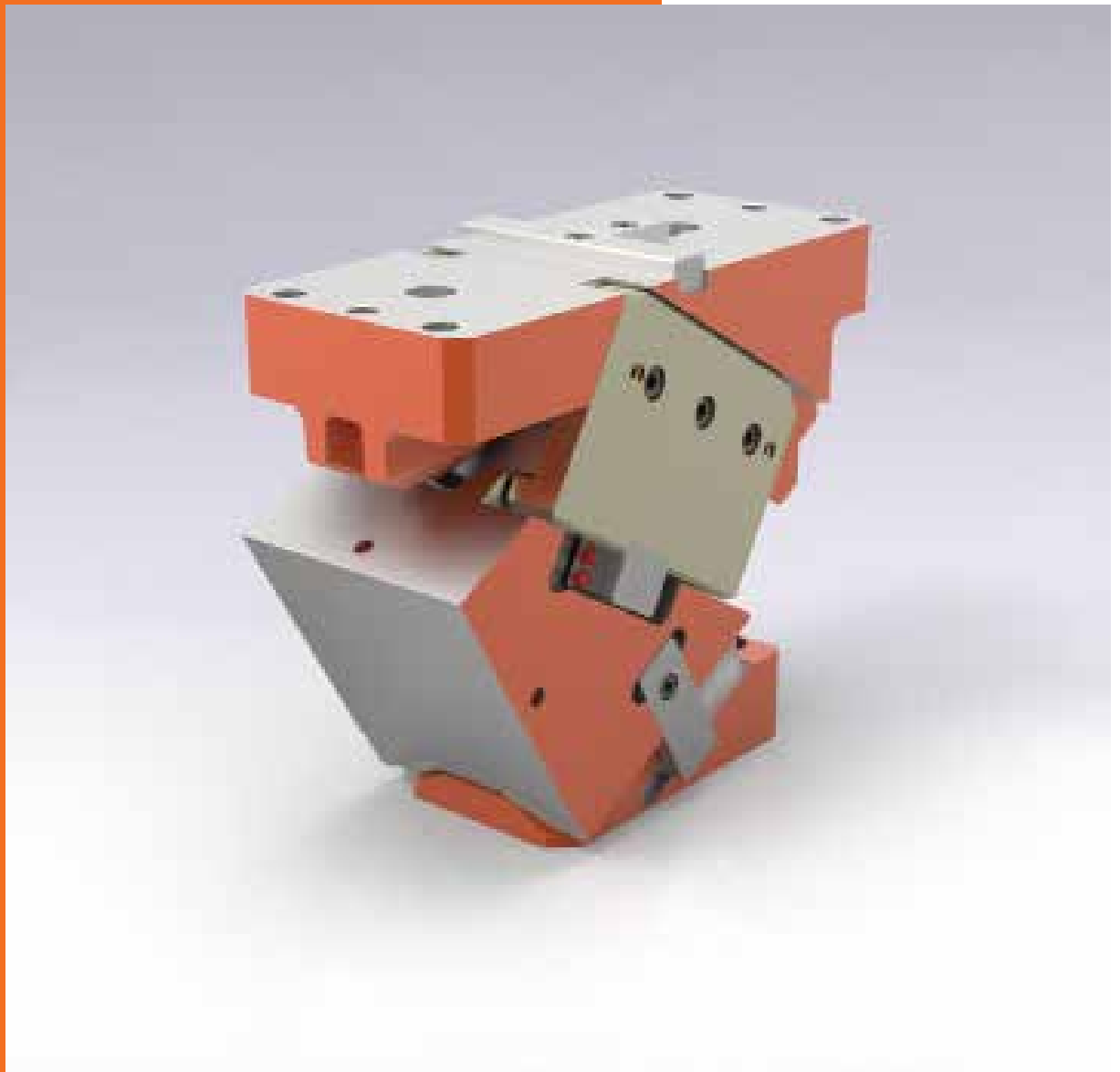

AERIAL FCC 2016.24.015.

Working width: 150 mm
Performance class: 425 kN

AERIAL FCC
2016.24.015.
 SIZE TABLE

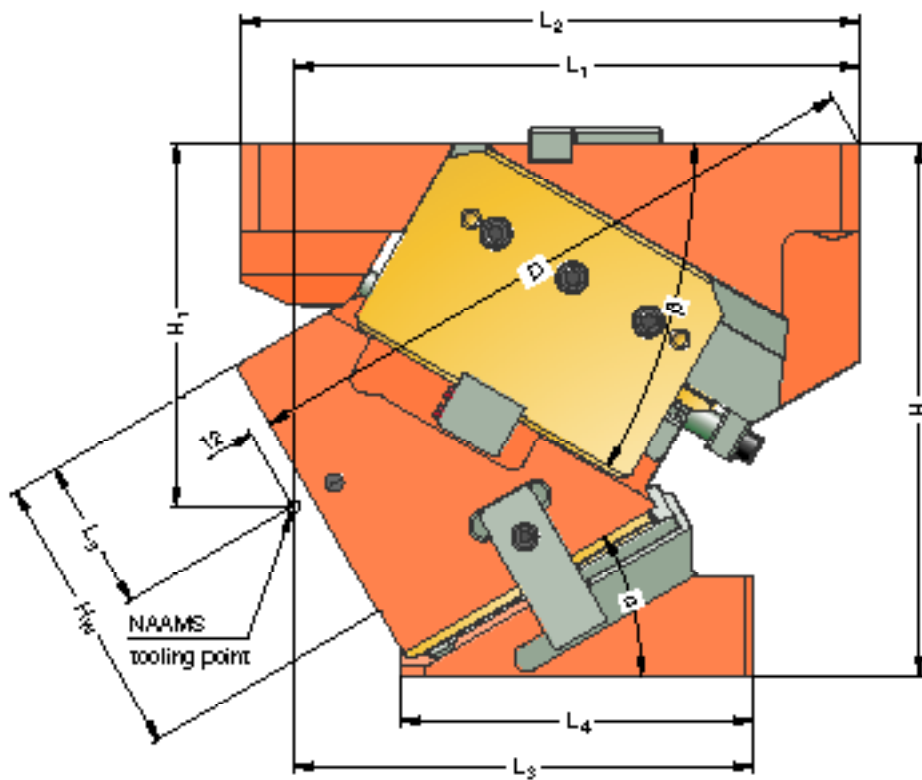
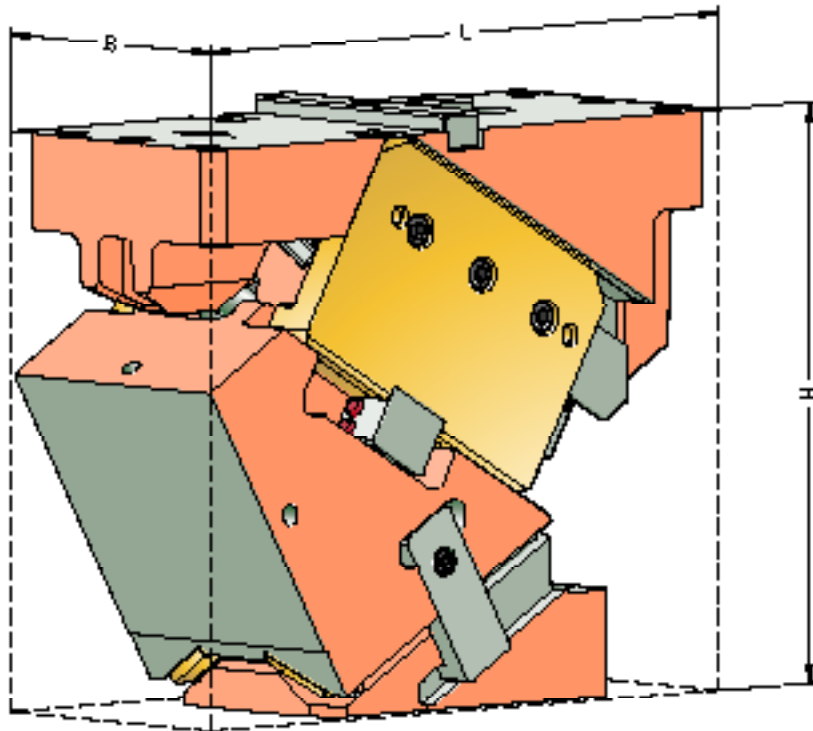

AERIAL FCC

2016.24.015.

SIZE TABLE

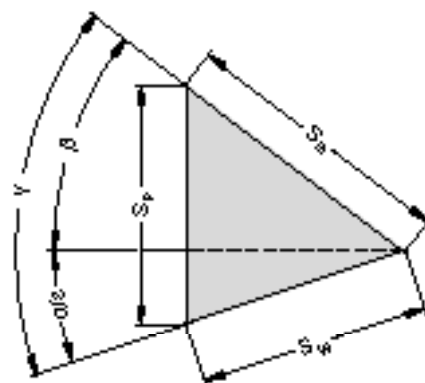

Order number	L [mm]	B [mm]	H [mm]	H ₁ [mm]	H _W [mm]	L ₁ [mm]	L ₂ [mm]	L ₃ [mm]	L ₄ [mm]	L ₅ [mm]	D [mm]	α [°]	β [°]	S _W * [mm]	S _S [mm]	S _p * [mm]
2016.24.015.00.1000.00	310	150	300	170	160	310	310	240	220	105	298.0	0	50	32.1	50	38.3
2016.24.015.05.1000.00	310	150	300	175	160	310	310	240	210	105	312.1	5	45	35.5	50	38.4
2016.24.015.10.1000.00	314	150	300	180	160	310	310	240	200	90	324.5	10	45	35.9	50	41.6
2016.24.015.15.1000.00	322	150	300	185	160	310	310	240	195	90	335.3	15	40	39.7	50	42.4
2016.24.015.20.1000.00	330	150	300	190	160	310	310	240	194	90	344.3	20	35	43.6	50	43.6
2016.24.015.25.1000.00	350	150	300	195	160	320	350	260	202	80	360.4	25	35	45.2	50	47.8
2016.24.015.30.1000.00	352	150	300	205	160	320	350	260	199	85	367.6	30	30	50.0	50	50.0
2016.24.015.35.1000.00	365	150	300	215	160	320	350	260	201	95	373.4	35	30	52.9	50	55.3
2016.24.015.40.1000.00	372	150	300	225	160	320	350	260	197	95	377.8	40	25	59.2	50	59.2
2016.24.015.45.1000.00	340	150	300	235	160	260	340	240	182	105	338.0	45	25	64.1	50	66.4
2016.24.015.50.1000.00	340	150	300	245	160	260	340	240	179	105	342.8	50	20	73.1	50	73.1
2016.24.015.55.1000.00	347	150	300	255	160	260	340	240	186	115	346.0	55	20	81.9	50	84.2
2016.24.015.60.1000.00	354	150	300	265	160	260	340	240	183	115	347.5	60	15	96.6	50	96.6
2016.24.015.65.1000.00	359	150	300	265	160	260	340	240	183	115	338.1	65	15	91.4	40	93.2
2016.24.015.70.1000.00	340	150	300	275	160	235	340	235	168	110	326.8	70	15	84.7	30	87.4
2016.24.015.75.1000.00	340	150	300	275	160	235	340	235	167	110	314.5	75	10	76.1	20	77.0

* Values rounded

Fastening cam base:

Hexagon socket head cap screws DIN EN ISO 4762
Dowel pins DIN EN ISO 8735

4x M16 / Strength class min. 8.8
2x Ø16

Fastening cam driver :

Hexagon socket head cap screws DIN EN ISO 4762
Dowel pins DIN EN ISO 8735

4x M16 / Strength class min. 8.8
2x Ø16

AERIAL FCC
2016.24.015.
EXPLODED VIEW

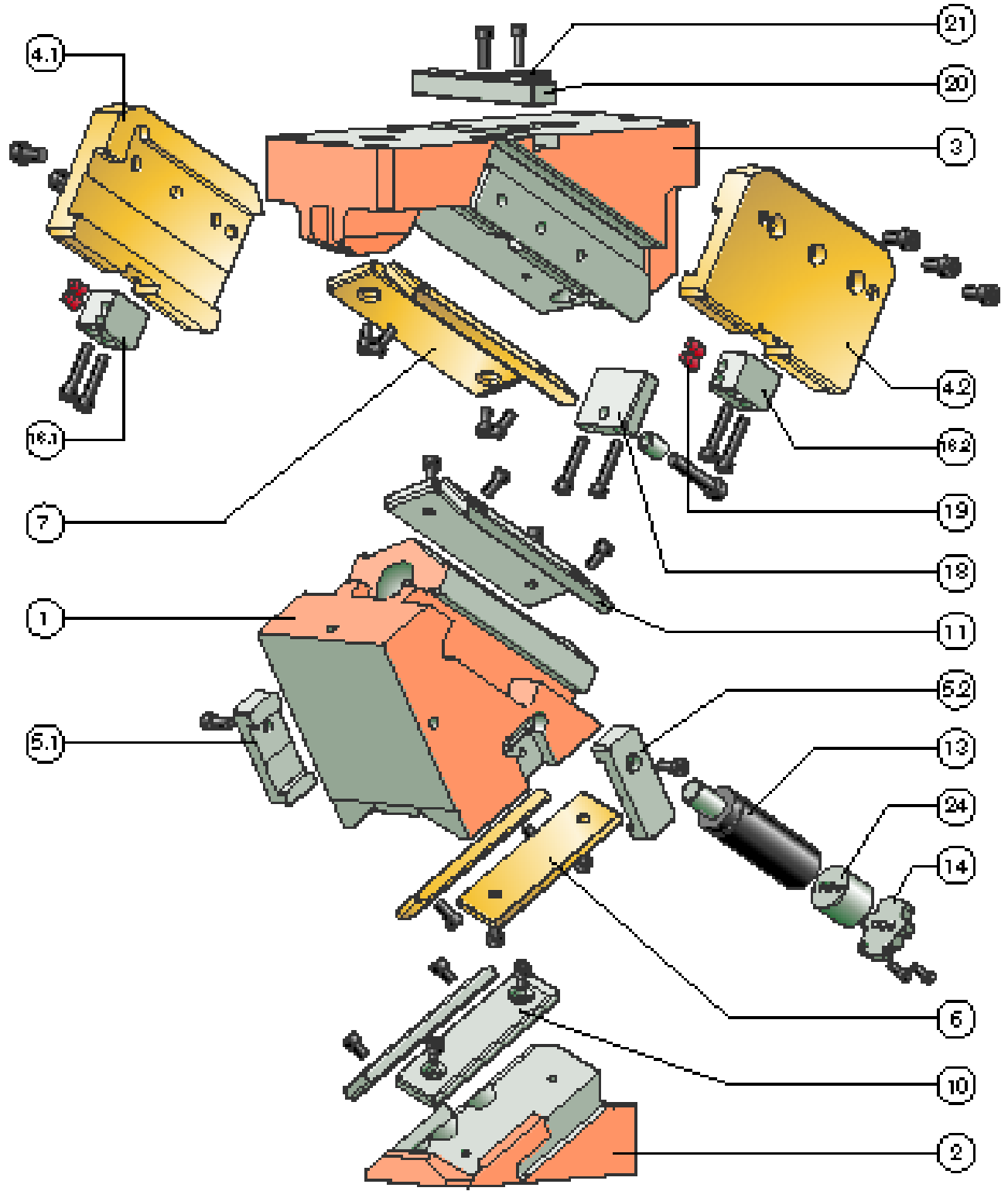

AERIAL FCC

2016.24.015.

PARTS LIST

Position	Piece	Designation	Material	spare part
1	1	Slider	GGG60	--
2	1	Cam driver	GGG60	--
2.1				
2.2				
3	1	Cam base	GGG60	--
4.1	1	Clamp, left	Bronze with solid lubricant	x
4.2	1	Clamp, right	Bronze with solid lubricant	x
5.1	1	Positive return, left	1.7225	x
5.2	1	Positive return, right	1.7225	x
6	2	Sliding plate	Bronze with solid lubricant	x
7	2	Sliding plate	Bronze with solid lubricant	x
8				
9				
10	2	Sliding plate	1.7131	x
11	2	Sliding plate	1.7131	x
12				
13	1	Gas spring	2487.12.00500.□□□	x
14	1	Stop plate	1.7225	x
15				
16.1	1	Cam slide stop, left	1.1191	x
16.2	1	Cam slide stop, right	1.1191	x
17				
18	1	Lockout system		x
19	4	Damping element	Elastomer	x
20	1	Feather key (T-nut)		x
21	1	Feather key (T-nut)		x
22				
23				
24	1	Spacer	1.1191	x

For inquiries or when ordering spare parts (x), we require the following data:

- ▶ Cam unit order no.
- ▶ Cam unit serial no.
- ▶ Item number / Designation / Spare part

AERIAL FCC 2016.24.015. SYSTEM AND SURROUNDING FORCES

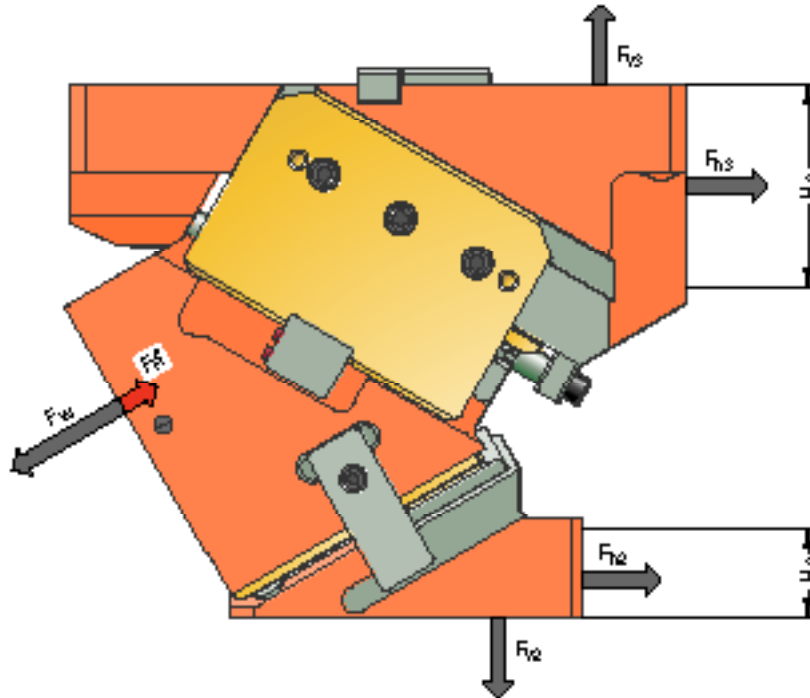

Order number	α [°]	F_W [kN]	F_R^* [kN]	F_{h2} [kN]	F_{v2} [kN]	F_{h3} [kN]	F_{v3} [kN]	H_2 [mm]	H_3 [mm]
2016.24.015.00.1000.00	0	421	7.6	0	353	421	353	27	160
2016.24.015.05.1000.00	5	435	7.7	32	364	402	402	40	150
2016.24.015.10.1000.00	10	448	8.4	54	309	387	387	35	150
2016.24.015.15.1000.00	15	462	8.4	84	312	363	432	40	140
2016.24.015.20.1000.00	20	476	8.4	114	313	333	476	40	130
2016.24.015.25.1000.00	25	489	9.5	119	256	324	463	40	130
2016.24.015.30.1000.00	30	503	9.5	145	252	290	503	40	120
2016.24.015.35.1000.00	35	517	10.9	138	197	285	494	40	120
2016.24.015.40.1000.00	40	528	10.9	158	189	246	528	40	100
2016.24.015.45.1000.00	45	540	13.0	139	139	243	521	50	100
2016.24.015.50.1000.00	50	551	13.0	154	129	201	551	50	97
2016.24.015.55.1000.00	55	558	16.2	122	86	198	543	60	82
2016.24.015.60.1000.00	60	565	16.2	131	76	151	565	60	85
2016.24.015.65.1000.00	65	571	23.4	91	43	150	560	70	85
2016.24.015.70.1000.00	70	578	33.9	48	17	150	560	80	84
2016.24.015.75.1000.00	75	584	31.6	49	13	102	577	80	90

* Retraction force values correspond to the spring-generated retraction force at the working point

The forces F_{h2} , F_{v2} as well as F_{h3} , F_{v3} act on the tool environment at maximum working force F_W .

AERIAL FCC

2016.24.015.

FORCE DIAGRAM

shouldered

Support with feather key

		Width 150 mm				
		35	30	20	30	35
Height 160 mm	32	53	112	226	112	53
	32	77	162	327	162	77
	32	101	212	428	212	101
	32	99	209	421	209	99
	32	97	205	414	205	97
	32					

		Width 150 mm				
		35	30	20	30	35
Height 160 mm	32	32	67	103	67	32
	32	46	88	103	88	46
	32	60	89	103	89	60
	32	59	90	103	90	59
	32	58	90	103	90	58
	32					

		Width 150 mm				
		35	30	20	30	35
Height 160 mm	32	51	107	223	107	51
	32	75	157	327	157	75
	32	98	207	432	207	98
	32	99	208	435	208	99
	32	95	200	417	200	95
	32					

		Width 150 mm				
		35	30	20	30	35
Height 160 mm	32	31	64	105	64	31
	32	45	87	108	87	45
	32	59	87	108	87	59
	32	59	87	108	87	59
	32	57	87	108	87	57
	32					

		Width 150 mm				
		35	30	20	30	35
Height 160 mm	32	49	102	219	102	49
	32	72	152	327	152	72
	32	96	202	436	202	96
	32	98	207	448	207	98
	32	93	196	420	196	93
	32					

		Width 150 mm				
		35	30	20	30	35
Height 160 mm	32	29	61	105	61	29
	32	43	91	113	91	43
	32	58	91	115	91	58
	32	59	91	115	91	59
	32	56	91	115	91	56
	32					

		Width 150 mm				
		35	30	20	30	35
Height 160 mm	32	46	98	215	98	46
	32	70	147	327	147	70
	32	94	197	439	197	94
	32	98	206	462	206	98
	32	91	191	423	191	91
	32					

		Width 150 mm				
		35	30	20	30	35
Height 160 mm	32	46	82	120	82	46
	32	60	85	120	85	60
	32	64	88	120	88	64
	32	64	88	120	88	64
	32	57	83	120	83	57
	32					

		Width 150 mm				
		35	30	20	30	35
Height 160 mm	32	44	93	212	93	44
	32	68	143	328	143	68
	32	92	192	443	192	92
	32	97	205	476	205	97
	32	88	186	427	186	88
	32					

		Width 150 mm				
		35	30	20	30	35
Height 160 mm	32	27	56	128	56	27
	32	41	86	133	86	41
	32	55	115	135	115	55
	32	58	115	135	115	58
	32	53	111	135	111	53
	32					

		Width 150 mm				
		35	30	20	30	35
Height 160 mm	32	42	88	208	88	42
	32	66	138	328	138	66
	32	89	187	447	187	89
	32	97	204	489	204	97
	32	86	181	430	181	86
	32					

		Width 150 mm				
		35	30	20	30	35
Height 160 mm	32	25	53	146	53	25
	32	39	83	152	83	39
	32	54	112	152	112	54
	32	58	112	152	112	58
	32	52	109	152	109	52
	32					

AERIAL FCC

2016.24.015.

FORCE DIAGRAM

shouldered

		Width 150 mm				
		35	30	20	30	35
Height 160 mm	32	40	83	205	83	40
	32	63	133	328	133	63
	32	87	182	451	182	87
	32	97	203	503	203	97
	32	84	176	433	176	84

		Width 150 mm				
		35	30	20	30	35
Height 160 mm	32	38	79	201	79	38
	32	61	128	328	128	61
	32	85	177	455	177	85
	32	96	202	517	202	96
	32	82	171	439	171	82

		Width 150 mm				
		35	30	20	30	35
Height 160 mm	32	38	81	198	81	38
	32	64	135	330	135	64
	32	89	190	461	190	89
	32	102	218	528	218	102
	32	85	181	441	181	85

		Width 150 mm				
		35	30	20	30	35
Height 160 mm	32	38	83	195	83	38
	32	66	142	332	142	66
	32	94	202	468	202	94
	32	108	233	540	233	108
	32	88	191	444	191	88

		Width 150 mm				
		35	30	20	30	35
Height 160 mm	32	39	85	191	85	39
	32	68	149	333	149	68
	32	98	214	475	214	98
	32	114	249	551	249	114
	32	92	200	447	200	92

		Width 150 mm				
		35	30	20	30	35
Height 160 mm	32	39	87	188	87	39
	32	71	157	335	157	71
	32	102	227	482	227	102
	32	120	265	558	265	120
	32	95	210	449	210	95

Support with feather key

		Width 150 mm				
		35	30	20	30	35
Height 160 mm	32	24	50	75	50	24
	32	38	80	163	80	38
	32	52	109	176	109	52
	32	58	122	176	122	58
	32	50	106	173	106	50

		Width 150 mm				
		35	30	20	30	35
Height 160 mm	32	23	47	65	47	23
	32	37	77	171	77	37
	32	51	106	180	106	51
	32	58	121	180	121	58
	32	49	103	180	103	49

		Width 150 mm				
		35	30	20	30	35
Height 160 mm	32	24	51	67	51	24
	32	40	85	177	85	40
	32	56	120	212	120	56
	32	56	137	214	137	56
	32	54	114	210	114	54

		Width 150 mm				
		35	30	20	30	35
Height 160 mm	32	24	52	69	52	24
	32	42	90	185	90	42
	32	59	128	213	128	59
	32	59	147	215	147	59
	32	56	120	210	120	56

		Width 150 mm				
		35	30	20	30	35
Height 160 mm	32	25	53	69	53	25
	32	43	94	187	94	43
	32	58	135	265	135	58
	32	58	157	263	157	58
	32	58	126	200	126	58

		Width 150 mm				
		35	30	20	30	35
Height 160 mm	32	25	55	77	55	25
	32	45	99	198	99	45
	32	65	143	275	143	65
	32	65	167	260	167	65
	32	60	132	205	132	60

AERIAL FCC

2016.24.015.

FORCE DIAGRAM

shouldered

		Width 150 mm				
		35	30	20	30	35
60°	Height 160 mm	40	89	185	89	40
	32	73	164	337	164	73
	32	107	239	489	239	107
	32	125	281	565	281	125
	32	98	219	452	219	98

Support with feather key

		Width 150 mm				
		35	30	20	30	35
60°	Height 160 mm	25	56	78	56	25
	32	46	103	123	103	46
	32	67	151	369	151	67
	32	67	178	372	178	67
	32	62	139	269	139	62

65°

		Width 150 mm				
		35	30	20	30	35
65°	Height 160 mm	40	91	182	91	40
	32	76	171	339	171	76
	32	111	251	496	251	111
	32	131	297	571	297	131
	32	101	229	448	229	101

65°

		Width 150 mm				
		35	30	20	30	35
65°	Height 160 mm	27	60	79	60	27
	32	50	95	103	95	50
	32	74	167	358	167	74
	32	74	198	362	198	74
	32	68	153	286	153	68

70°

		Width 150 mm				
		35	30	20	30	35
70°	Height 160 mm	41	93	178	93	41
	32	78	178	341	178	78
	32	115	263	499	263	115
	32	137	313	578	313	137
	32	105	239	438	239	105

70°

		Width 150 mm				
		35	30	20	30	35
70°	Height 160 mm	27	62	77	62	27
	32	52	97	103	97	52
	32	77	176	375	176	77
	32	77	209	375	209	77
	32	70	159	290	159	70

75°

		Width 150 mm				
		35	30	20	30	35
75°	Height 160 mm	41	95	175	95	41
	32	80	185	343	185	80
	32	120	276	501	276	120
	32	143	329	584	329	143
	32	108	248	427	248	108

75°

		Width 150 mm				
		35	30	20	30	35
75°	Height 160 mm	27	63	75	63	27
	32	54	75	83	75	54
	32	80	184	367	184	80
	32	80	219	523	219	80
	32	72	166	325	166	72



AERIAL FCC 2016.24.018.

Working width: 180 mm
Performance class: 500 kN

AERIAL FCC
2016.24.018.
 SIZE TABLE

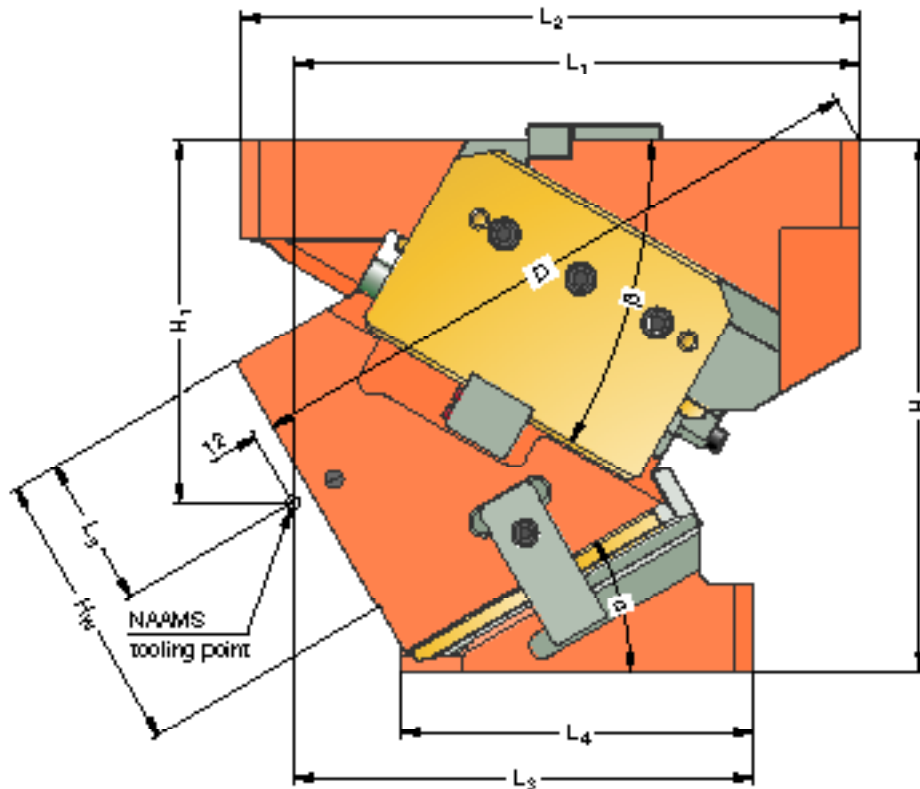
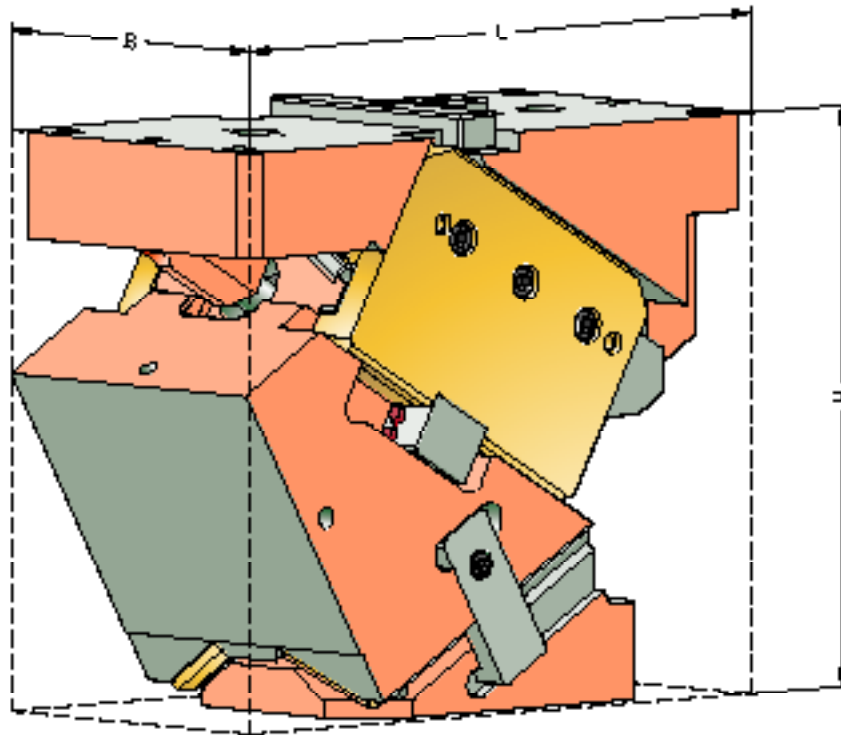

AERIAL FCC

2016.24.018.

SIZE TABLE

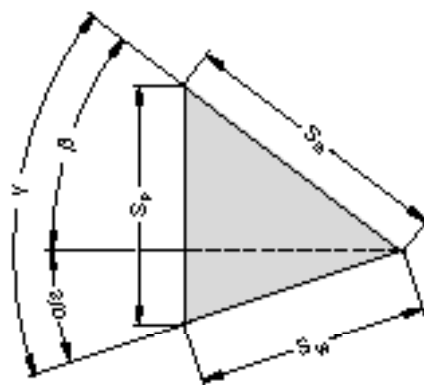

Order number	L [mm]	B [mm]	H [mm]	H ₁ [mm]	H _W [mm]	L ₁ [mm]	L ₂ [mm]	L ₃ [mm]	L ₄ [mm]	L ₅ [mm]	D [mm]	α [°]	β [°]	S _W * [mm]	S _S [mm]	S _P * [mm]
2016.24.018.00.1000.00	310	180	300	170	160	310	310	240	220	105	298.0	0	50	32.1	50	38.3
2016.24.018.05.1000.00	310	180	300	175	160	310	310	240	210	105	312.0	5	45	35.5	50	38.4
2016.24.018.10.1000.00	314	180	300	180	160	310	310	240	200	90	324.5	10	45	35.9	50	41.6
2016.24.018.15.1000.00	322	180	300	185	160	310	310	240	195	90	335.3	15	40	39.7	50	42.4
2016.24.018.20.1000.00	330	180	300	190	160	310	310	240	191	90	344.3	20	35	43.6	50	43.6
2016.24.018.25.1000.00	350	180	300	195	160	320	350	260	199	80	360.4	25	35	45.2	50	47.8
2016.24.018.30.1000.00	352	180	300	205	160	320	350	260	199	85	367.6	30	30	50.0	50	50.0
2016.24.018.35.1000.00	365	180	300	215	160	320	350	260	201	95	373.5	35	30	52.9	50	55.3
2016.24.018.40.1000.00	372	180	300	225	160	320	350	260	197	95	377.8	40	25	59.2	50	59.2
2016.24.018.45.1000.00	340	180	300	235	160	260	340	240	182	105	338.0	45	25	64.1	50	66.4
2016.24.018.50.1000.00	340	180	300	245	160	260	340	240	179	105	342.8	50	20	73.1	50	73.1
2016.24.018.55.1000.00	347	180	300	255	160	260	340	240	186	115	346.0	55	20	81.9	50	84.2
2016.24.018.60.1000.00	354	180	300	265	160	260	340	240	182	115	347.5	60	15	96.6	50	96.6
2016.24.018.65.1000.00	359	180	300	265	160	260	340	240	181	115	338.1	65	15	91.4	40	93.2
2016.24.018.70.1000.00	340	180	300	275	160	235	340	235	168	110	326.8	70	15	84.7	30	87.4
2016.24.018.75.1000.00	340	180	300	275	160	235	340	235	172	110	314.5	75	10	76.1	20	77.0

* Values rounded

Fastening cam base:

Hexagon socket head cap screws DIN EN ISO 4762
Dowel pins DIN EN ISO 8735

4x M16 / Strength class min. 8.8
2x Ø16

Fastening cam driver :

Hexagon socket head cap screws DIN EN ISO 4762
Dowel pins DIN EN ISO 8735

4x M16 / Strength class min. 8.8
2x Ø16

AERIAL FCC
2016.24.018.
EXPLODED VIEW

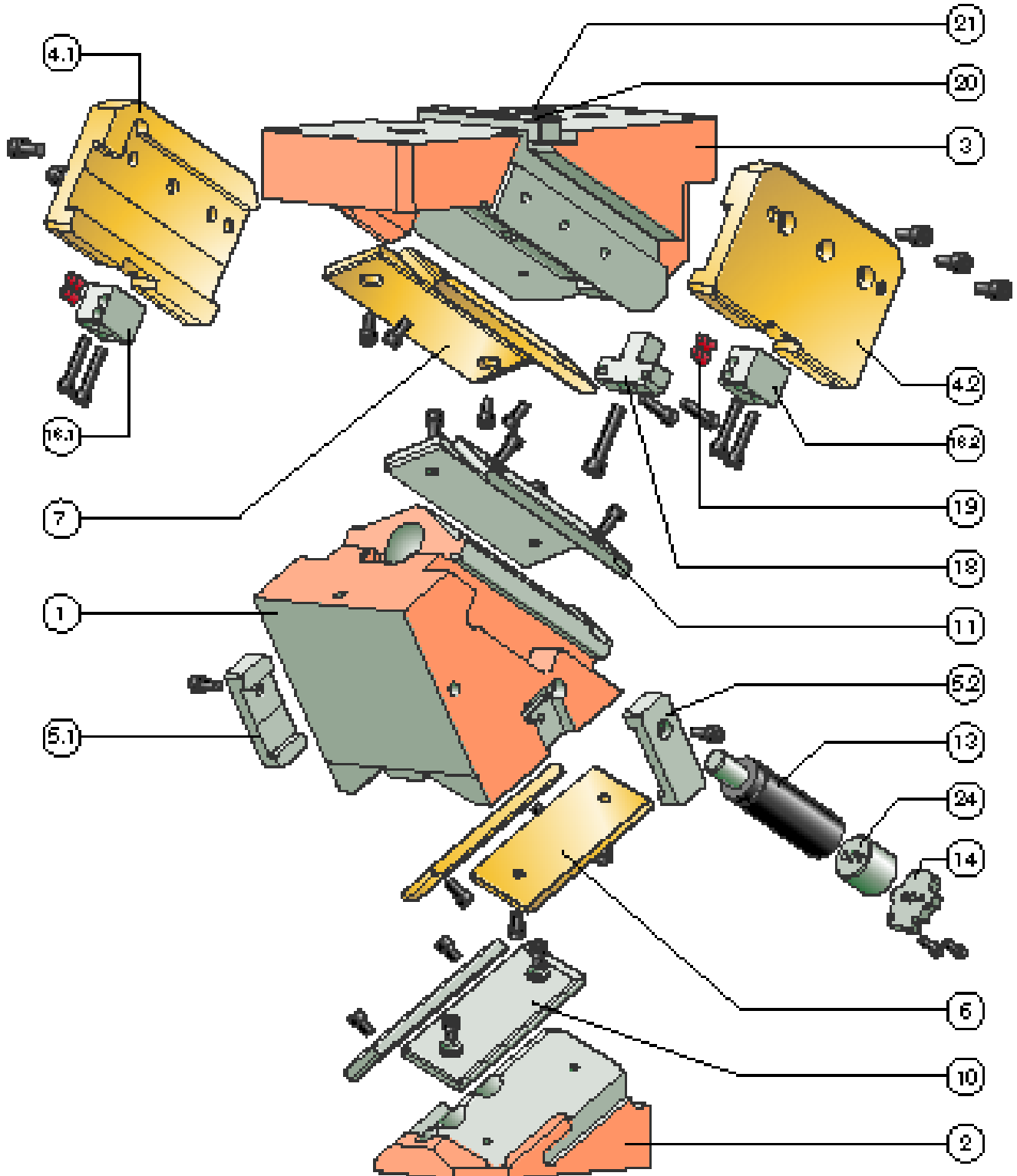

AERIAL FCC

2016.24.018.

PARTS LIST

Position	Piece	Designation	Material	spare part
1	1	Slider	GGG60	--
2	1	Cam driver	GGG60	--
2.1				
2.2				
3	1	Cam base	GGG60	--
4.1	1	Clamp, left	Bronze with solid lubricant	x
4.2	1	Clamp, right	Bronze with solid lubricant	x
5.1	1	Positive return, left	1.7225	x
5.2	1	Positive return, right	1.7225	x
6	2	Sliding plate	Bronze with solid lubricant	x
7	2	Sliding plate	Bronze with solid lubricant	x
8				
9				
10	2	Sliding plate	1.7131	x
11	2	Sliding plate	1.7131	x
12				
13	1	Gas spring	2487.12.00500.□□□	x
14	1	Stop plate	1.7225	x
15				
16.1	1	Cam slide stop, left	1.1191	
16.2	1	Cam slide stop, right	1.1191	
17				
18	1	Lockout system		x
19	4	Damping element	Elastomer	x
20	1	Feather key (T-nut)		x
21	1	Feather key (T-nut)		x
22				
23				
24	1	Spacer	1.1191	x

For inquiries or when ordering spare parts (x), we require the following data:

- ▶ Cam unit order no.
- ▶ Cam unit serial no.
- ▶ Item number / Designation / Spare part

AERIAL FCC 2016.24.018. SYSTEM AND SURROUNDING FORCES

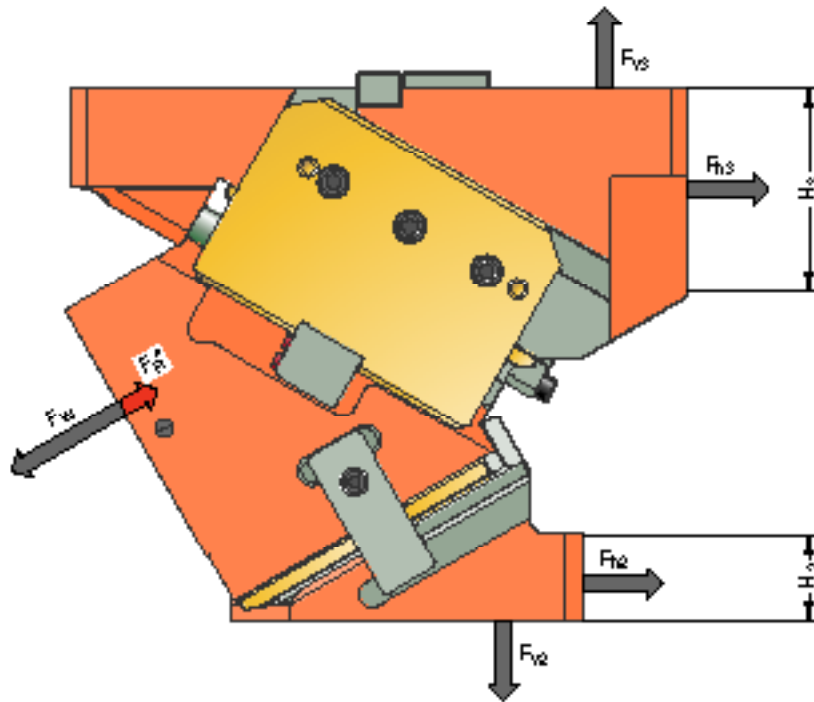

Order number	α [°]	F_W [kN]	F_R^* [kN]	F_{h2} [kN]	F_{v2} [kN]	F_{h3} [kN]	F_{v3} [kN]	H_2 [mm]	H_3 [mm]
2016.24.018.00.1000.00	0	474	7.7	0	398	474	398	27	160
2016.24.018.05.1000.00	5	488	7.7	36	408	450	450	40	150
2016.24.018.10.1000.00	10	503	8.5	61	347	434	434	27	150
2016.24.018.15.1000.00	15	518	8.5	94	350	406	484	27	140
2016.24.018.20.1000.00	20	533	8.5	128	351	373	533	27	130
2016.24.018.25.1000.00	25	542	9.5	132	284	359	513	40	130
2016.24.018.30.1000.00	30	543	9.5	157	272	314	543	40	117
2016.24.018.35.1000.00	35	543	11.0	145	207	300	519	40	117
2016.24.018.40.1000.00	40	550	11.0	165	196	256	550	40	100
2016.24.018.45.1000.00	45	557	13.0	143	143	251	537	50	100
2016.24.018.50.1000.00	50	564	13.0	157	132	205	564	50	81
2016.24.018.55.1000.00	55	571	16.3	125	88	202	555	60	66
2016.24.018.60.1000.00	60	578	16.3	134	77	155	578	60	70
2016.24.018.65.1000.00	65	584	21.9	93	44	153	573	60	74
2016.24.018.70.1000.00	70	591	34.0	49	18	154	573	80	84
2016.24.018.75.1000.00	75	598	31.6	51	14	104	591	90	63

* Retraction force values correspond to the spring-generated retraction force at the working point

The forces F_{h2} , F_{v2} as well as F_{h3} , F_{v3} act on the tool environment at maximum working force F_W .

AERIAL FCC

2016.24.018.

FORCE DIAGRAM

shouldered

Support with feather key

		Width 180 mm				
		40	40	20	40	40
Height 160 mm	32	83	172	244	172	83
	32	109	226	321	226	109
	32	135	280	397	280	135
	32	184	333	474	333	184
	32	99	117	167	117	99
	32					

		Width 180 mm				
		40	40	20	40	40
Height 160 mm	32	50	84	117	84	50
	32	65	84	117	84	65
	32	65	85	117	85	65
	32	65	86	117	86	65
	32	59	82	117	82	59
	32					

		Width 180 mm				
		40	40	20	40	40
Height 160 mm	32	81	158	233	158	81
	32	106	207	305	207	106
	32	132	276	378	276	132
	32	191	356	488	356	191
	32	120	153	199	153	120
	32					

		Width 180 mm				
		40	40	20	40	40
Height 160 mm	32	49	93	115	93	49
	32	64	99	118	99	64
	32	72	99	122	99	72
	32	72	99	123	99	72
	32	72	96	122	96	72
	32					

		Width 180 mm				
		40	40	20	40	40
Height 160 mm	32	79	143	221	143	79
	32	104	187	290	187	104
	32	129	272	359	272	129
	32	198	338	503	338	198
	32	133	188	232	188	133
	32					

		Width 180 mm				
		40	40	20	40	40
Height 160 mm	32	47	100	130	100	47
	32	62	108	132	108	62
	32	77	112	135	112	77
	32	78	112	135	112	78
	32	76	110	134	110	76
	32					

		Width 180 mm				
		40	40	20	40	40
Height 160 mm	32	77	128	209	128	77
	32	101	168	274	168	101
	32	125	267	340	267	125
	32	205	317	518	317	205
	32	146	212	264	212	146
	32					

		Width 180 mm				
		40	40	20	40	40
Height 160 mm	32	46	90	125	90	46
	32	61	113	140	113	61
	32	75	118	145	118	75
	32	75	118	146	118	75
	32	75	116	143	116	75
	32					

		Width 180 mm				
		40	40	20	40	40
Height 160 mm	32	75	113	197	113	75
	32	99	149	259	149	99
	32	122	263	321	263	122
	32	211	296	533	296	211
	32	159	209	297	209	159
	32					

		Width 180 mm				
		40	40	20	40	40
Height 160 mm	32	45	79	118	79	45
	32	59	104	155	104	59
	32	73	125	164	125	73
	32	73	125	166	125	73
	32	73	125	163	125	73
	32					

		Width 180 mm				
		40	40	20	40	40
Height 160 mm	32	73	98	185	98	73
	32	96	129	243	129	96
	32	119	259	302	259	119
	32	218	275	542	279	218
	32	172	205	330	205	172
	32					

		Width 180 mm				
		40	40	20	40	40
Height 160 mm	32	44	69	111	69	44
	32	58	91	146	91	58
	32	71	188	175	188	71
	32	71	142	178	142	71
	32	70	143	176	143	70
	32					

AERIAL FCC

2016.24.018.

FORCE DIAGRAM

shouldered

		Width 180 mm				
		40	40	20	40	40
Height 160 mm	32	71	84	173	84	71
	32	93	110	228	110	93
	32	116	255	283	255	116
	32	225	253	543	253	225
	32	185	201	362	201	185

		Width 180 mm				
		40	40	20	40	40
Height 160 mm	32	69	69	161	69	69
	32	91	91	212	91	91
	32	113	251	264	251	113
	32	232	232	543	232	232
	32	198	198	427	198	198

		Width 180 mm				
		40	40	20	40	40
Height 160 mm	32	64	70	164	70	64
	32	86	96	227	96	86
	32	108	244	289	244	108
	32	215	234	550	234	215
	32	181	194	433	194	181

		Width 180 mm				
		40	40	20	40	40
Height 160 mm	32	59	71	167	71	59
	32	81	102	241	102	81
	32	103	236	315	236	103
	32	198	235	557	235	198
	32	165	190	438	190	165

		Width 180 mm				
		40	40	20	40	40
Height 160 mm	32	54	71	170	71	54
	32	76	107	255	107	76
	32	99	229	341	229	99
	32	181	237	564	237	181
	32	148	187	443	187	148

		Width 180 mm				
		40	40	20	40	40
Height 160 mm	32	49	72	173	72	49
	32	72	112	270	112	72
	32	94	222	367	222	94
	32	164	239	571	239	164
	32	132	183	436	183	132

Support with feather key

		Width 180 mm				
		40	40	20	40	40
Height 160 mm	32	43	83	104	83	43
	32	57	110	169	110	57
	32	69	137	178	137	69
	32	75	149	193	149	75
	32	67	141	181	141	67

		Width 180 mm				
		40	40	20	40	40
Height 160 mm	32	41	48	98	48	41
	32	54	64	127	64	54
	32	68	150	158	150	68
	32	68	152	216	152	68
	32	68	139	214	139	68

		Width 180 mm				
		40	40	20	40	40
Height 160 mm	32	40	51	64	51	40
	32	54	71	141	71	54
	32	68	172	238	172	68
	32	68	172	241	172	68
	32	57	143	237	143	57

		Width 180 mm				
		40	40	20	40	40
Height 160 mm	32	37	52	72	52	37
	32	51	75	152	75	51
	32	65	174	256	174	65
	32	65	173	260	173	65
	32	60	140	210	140	60

		Width 180 mm				
		40	40	20	40	40
Height 160 mm	32	34	53	72	53	34
	32	48	79	153	79	48
	32	62	169	310	169	62
	32	62	175	313	175	62
	32	48	138	211	138	48

		Width 180 mm				
		40	40	20	40	40
Height 160 mm	32	31	61	74	61	31
	32	49	96	160	96	49
	32	59	189	314	189	59
	32	59	203	315	203	59
	32	53	156	210	156	53

AERIAL FCC

2016.24.018.

FORCE DIAGRAM

shouldered

		Width 180 mm				
		40	40	20	40	40
60°	Height 160 mm	44	73	176	73	44
	32	67	118	284	118	67
	32	89	215	393	215	89
	32	147	240	578	240	147
	32	115	179	430	179	115
	32					

Support with feather key

		Width 180 mm				
		40	40	20	40	40
60°	Height 160 mm	28	62	111	62	28
	32	42	100	179	100	42
	32	56	182	248	182	56
	32	56	204	365	204	56
	32	56	152	271	152	56
	32					

65°

		Width 180 mm				
		40	40	20	40	40
65°	Height 160 mm	39	74	179	74	39
	32	62	123	299	123	62
	32	84	207	418	207	84
	32	130	242	584	242	130
	32	99	176	423	176	99
	32					

65°

		Width 180 mm				
		40	40	20	40	40
65°	Height 160 mm	26	69	119	69	26
	32	41	115	199	115	41
	32	56	193	279	193	56
	32	56	225	390	225	56
	32	56	163	282	163	56
	32					

70°

		Width 180 mm				
		40	40	20	40	40
70°	Height 160 mm	34	75	182	75	34
	32	57	129	313	129	57
	32	80	200	444	200	80
	32	113	244	591	244	113
	32	82	172	417	172	82
	32					

70°

		Width 180 mm				
		40	40	20	40	40
70°	Height 160 mm	23	75	76	75	23
	32	38	129	209	129	38
	32	53	200	296	200	53
	32	55	244	394	244	55
	32	55	172	278	172	55
	32					

75°

		Width 180 mm				
		40	40	20	40	40
75°	Height 160 mm	29	76	184	76	29
	32	52	134	327	134	52
	32	75	193	470	193	75
	32	96	245	598	245	96
	32	65	168	410	168	65
	32					

75°

		Width 180 mm				
		40	40	20	40	40
75°	Height 160 mm	20	76	76	76	20
	32	35	134	218	134	35
	32	50	193	313	193	50
	32	50	245	399	245	50
	32	44	168	273	168	44
	32					



AERIAL FCC 2016.24.022.

Working width: 220 mm
Performance class: 600 kN

AERIAL FCC
2016.24.022.
 SIZE TABLE

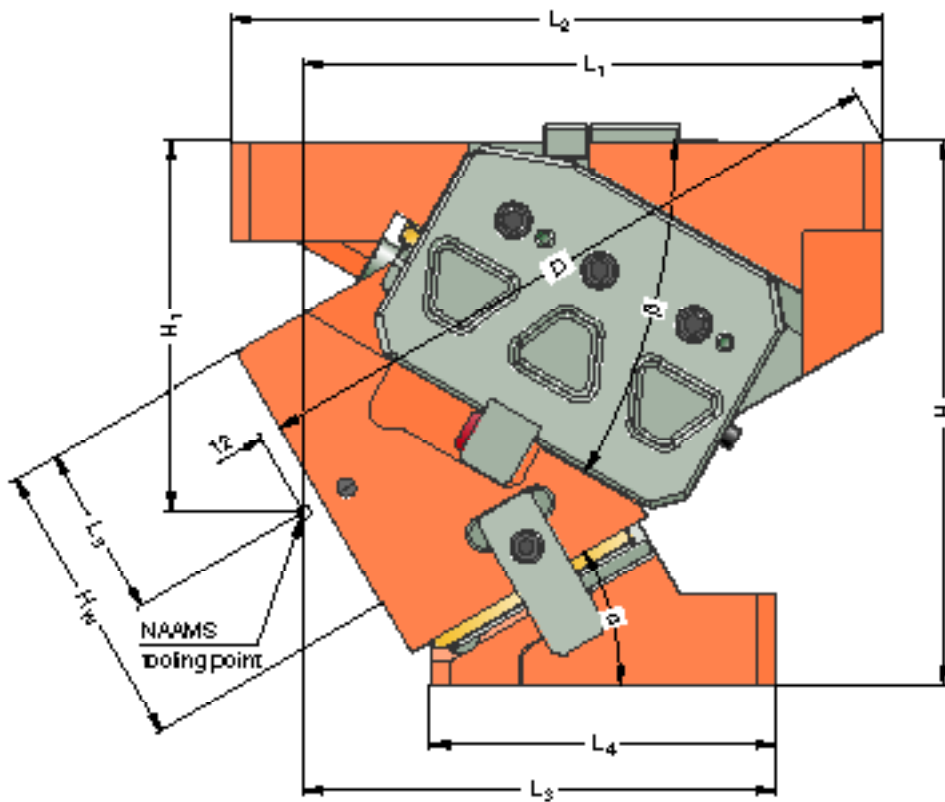
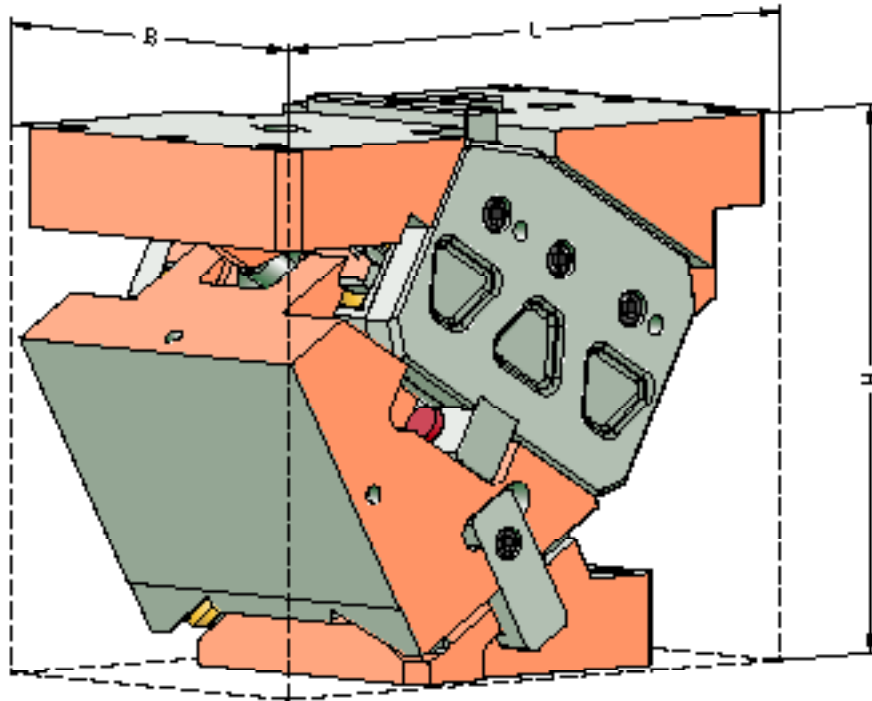

AERIAL FCC

2016.24.022.

SIZE TABLE

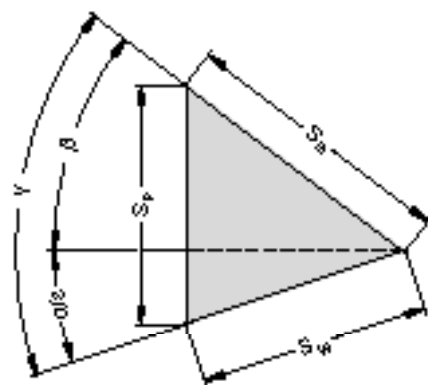

Order number	L [mm]	B [mm]	H [mm]	H ₁ [mm]	H _W [mm]	L ₁ [mm]	L ₂ [mm]	L ₃ [mm]	L ₄ [mm]	L ₅ [mm]	D [mm]	α [°]	β [°]	S _W * [mm]	S _S [mm]	S _P * [mm]
2016.24.022.00.1000.00	320	220	300	170	160	320	320	240	215	110	308.0	0	50	32.1	50	38.3
2016.24.022.05.1000.00	320	220	300	175	160	320	320	240	210	110	322.0	5	45	35.5	50	38.4
2016.24.022.10.1000.00	324	220	300	180	160	320	320	240	200	90	334.4	10	45	35.9	50	41.6
2016.24.022.15.1000.00	332	220	300	185	160	320	320	240	190	90	345.0	15	40	39.7	50	42.4
2016.24.022.20.1000.00	338	220	300	190	160	320	320	240	185	85	353.7	20	35	43.6	50	43.6
2016.24.022.25.1000.00	360	220	300	195	160	320	360	260	195	85	360.4	25	35	45.2	50	47.8
2016.24.022.30.1000.00	360	220	300	205	160	320	360	260	190	95	375.7	30	30	50.0	50	50.0
2016.24.022.35.1000.00	363	220	300	215	160	320	360	260	185	92	373.4	35	30	52.9	50	55.3
2016.24.022.40.1000.00	373	220	300	225	160	320	360	260	180	97	377.8	40	25	59.2	50	59.2
2016.24.022.45.1000.00	365	220	300	235	160	285	365	240	160	102	355.7	45	25	64.1	50	66.4
2016.24.022.50.1000.00	365	220	300	245	160	285	365	240	160	102	358.9	50	20	73.1	50	73.1
2016.24.022.55.1000.00	365	220	300	255	160	285	365	240	161	102	360.4	55	20	81.9	50	84.2
2016.24.022.60.1000.00	372	220	300	265	160	285	365	240	159	107	360.0	60	15	96.6	50	96.6
2016.24.022.65.1000.00	368	220	300	265	160	285	365	240	161	97	348.6	65	15	91.4	40	93.2
2016.24.022.70.1000.00	372	220	300	265	160	285	365	240	163	97	334.5	70	10	100.8	35	100.8
2016.24.022.75.1000.00	365	220	300	280	160	275	365	240	145	83	329.6	75	10	95.1	25	96.2

* Values rounded

Fastening cam base:

Hexagon socket head cap screws DIN EN ISO 4762
Dowel pins DIN EN ISO 8735

4x M16 / Strength class min. 8.8
2x Ø16

Fastening cam driver :

Hexagon socket head cap screws DIN EN ISO 4762
Dowel pins DIN EN ISO 8735

4x M16 / Strength class min. 8.8
2x Ø16

AERIAL FCC
2016.24.022.
 EXPLODED VIEW

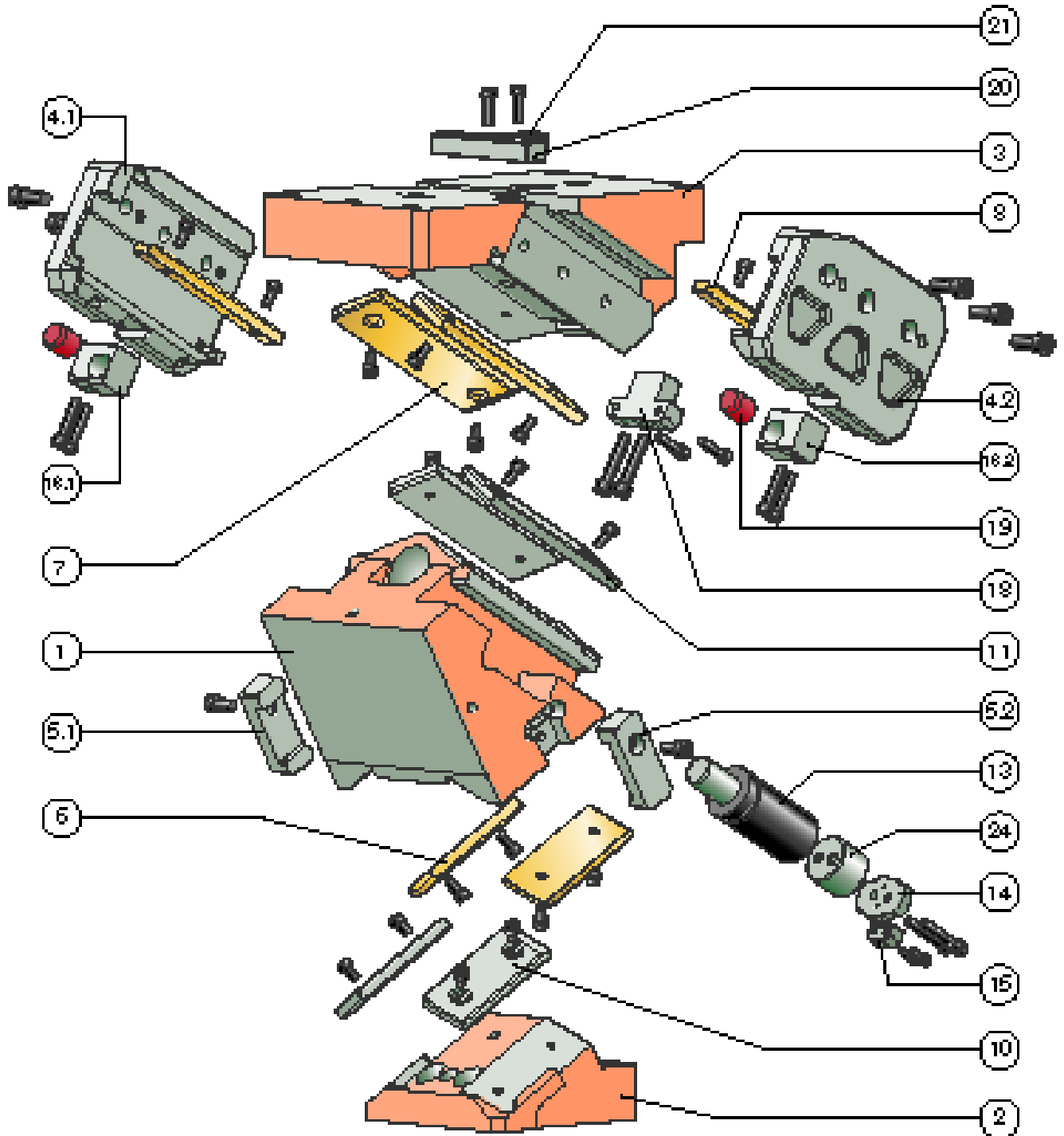

AERIAL FCC

2016.24.022.

PARTS LIST

Position	Piece	Designation	Material	spare part
1	1	Slider	GGG60	--
2	1	Cam driver	GGG60	--
2.1				
2.2				
3	1	Cam base	GGG60	--
4.1	1	Clamp, left	1.7225	x
4.2	1	Clamp, right	1.7225	x
5.1	1	Positive return, left	1.7225	x
5.2	1	Positive return, right	1.7225	x
6	2	Sliding plate	Bronze with solid lubricant	x
7	2	Sliding plate	Bronze with solid lubricant	x
8	2	Sliding plate	Bronze with solid lubricant	x
9				
10	2	Sliding plate	1.7131	x
11	2	Sliding plate	1.7131	x
12				
13	1	Gas spring	2487.12.00750.□□□	x
14	1	Stop plate	1.7225	x
15	1	Safety plate	1.1191	x
16.1	1	Cam slide stop, left	1.1191	x
16.2	1	Cam slide stop, right	1.1191	x
17				
18	1	Lockout system		x
19	2	Damping element	Elastomer	x
20	1	Feather key (T-nut)		x
21	1	Feather key (T-nut)		x
22				
23				
24	1	Spacer	1.1191	x

For inquiries or when ordering spare parts (x), we require the following data:

- ▶ Cam unit order no.
- ▶ Cam unit serial no.
- ▶ Item number / Designation / Spare part

AERIAL FCC

2016.24.022.

SYSTEM AND SURROUNDING FORCES

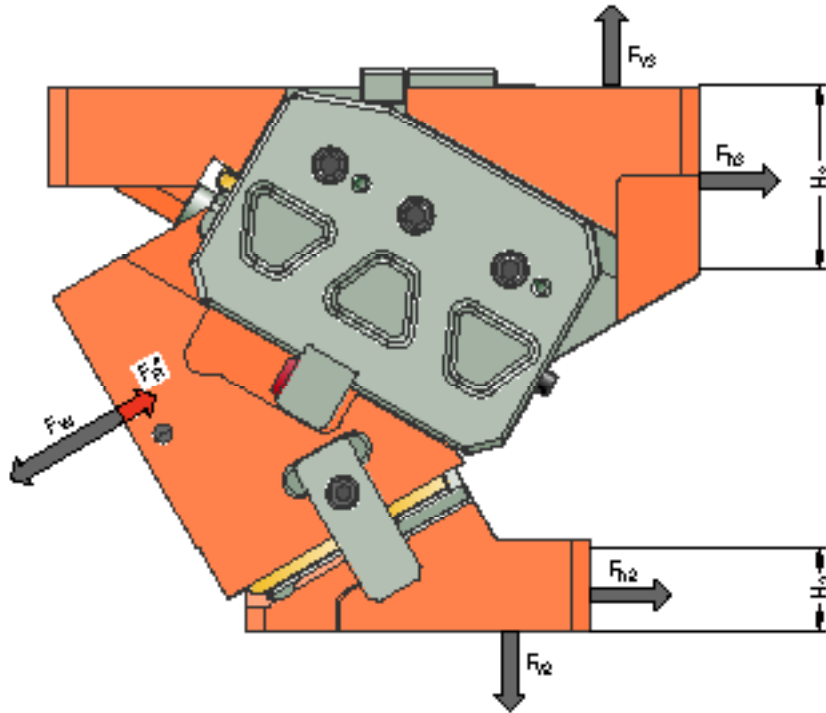

Order number	α [°]	F_W [kN]	F_R^* [kN]	F_{h2} [kN]	F_{v2} [kN]	F_{h3} [kN]	F_{v3} [kN]	H_2 [mm]	H_3 [mm]
2016.24.022.00.1000.00	0	635	12.4	0	533	635	533	40	160
2016.24.022.05.1000.00	5	648	12.5	47	542	598	598	40	150
2016.24.022.10.1000.00	10	661	13.7	80	456	571	571	40	150
2016.24.022.15.1000.00	15	674	13.7	122	456	529	630	40	140
2016.24.022.20.1000.00	20	687	13.8	165	452	481	687	20	130
2016.24.022.25.1000.00	25	700	15.5	171	366	464	662	40	130
2016.24.022.30.1000.00	30	714	15.5	206	357	412	714	40	104
2016.24.022.35.1000.00	35	727	17.8	194	278	401	695	40	107
2016.24.022.40.1000.00	40	727	17.9	218	260	339	727	40	93
2016.24.022.45.1000.00	45	728	21.3	187	187	327	702	50	100
2016.24.022.50.1000.00	50	729	21.3	203	171	265	729	40	61
2016.24.022.55.1000.00	55	729	26.7	160	112	258	709	60	53
2016.24.022.60.1000.00	60	730	26.7	169	98	196	730	60	67
2016.24.022.65.1000.00	65	730	34.1	117	54	192	716	60	72
2016.24.022.70.1000.00	70	731	33.1	121	44	129	731	80	58
2016.24.022.75.1000.00	75	732	50.2	62	17	128	724	90	56

* Retraction force values correspond to the spring-generated retraction force at the working point

The forces F_{h2} , F_{v2} as well as F_{h3} , F_{v3} act on the tool environment at maximum working force F_W .

AERIAL FCC

2016.24.022.

FORCE DIAGRAM

shouldered

Support with feather key

		Width 220 mm				
		50	50	20	50	50
Height 160 mm	32	69	154	307	154	69
	32	86	192	384	192	86
	32	103	231	460	231	103
	32	143	318	635	318	143
	32	89	198	396	198	89
	32					

		Width 220 mm				
		50	50	20	50	50
Height 160 mm	32	41	85	140	85	41
	32	52	106	140	106	52
	32	62	113	140	113	62
	32	67	113	140	113	67
	32	53	109	140	109	53
	32					

		Width 220 mm				
		50	50	20	50	50
Height 160 mm	32	75	159	306	159	75
	32	95	201	390	201	95
	32	153	328	475	328	153
	32	107	218	648	218	107
	32	105	219	415	219	105
	32					

		Width 220 mm				
		50	50	20	50	50
Height 160 mm	32	45	87	153	87	45
	32	57	111	155	111	57
	32	69	119	155	119	69
	32	64	119	155	119	64
	32	63	119	155	119	63
	32					

		Width 220 mm				
		50	50	20	50	50
Height 160 mm	32	79	162	305	162	79
	32	102	207	397	207	102
	32	117	228	489	228	117
	32	123	239	661	239	123
	32	121	240	435	240	121
	32					

		Width 220 mm				
		50	50	20	50	50
Height 160 mm	32	47	89	152	89	47
	32	61	114	156	114	61
	32	70	125	156	125	70
	32	74	131	156	131	74
	32	73	132	156	132	73
	32					

		Width 220 mm				
		50	50	20	50	50
Height 160 mm	32	82	162	304	162	82
	32	109	212	404	212	109
	32	134	250	504	250	134
	32	139	260	674	260	139
	32	138	261	454	261	138
	32					

		Width 220 mm				
		50	50	20	50	50
Height 160 mm	32	49	89	152	89	49
	32	65	116	174	116	65
	32	72	137	174	137	72
	32	72	137	174	137	72
	32	72	137	174	137	72
	32					

		Width 220 mm				
		50	50	20	50	50
Height 160 mm	32	85	162	302	162	85
	32	116	217	410	217	116
	32	151	271	518	271	151
	32	156	281	687	281	156
	32	154	282	473	282	154
	32					

		Width 220 mm				
		50	50	20	50	50
Height 160 mm	32	51	89	151	89	51
	32	69	119	196	119	69
	32	74	149	196	149	74
	32	74	154	196	154	74
	32	74	155	196	155	74
	32					

		Width 220 mm				
		50	50	20	50	50
Height 160 mm	32	89	162	301	162	89
	32	123	222	417	222	123
	32	168	293	532	293	168
	32	172	301	700	301	172
	32	170	303	493	303	170
	32					

		Width 220 mm				
		50	50	20	50	50
Height 160 mm	32	53	89	151	89	53
	32	74	122	208	122	74
	32	86	152	208	152	86
	32	86	152	208	152	86
	32	86	152	208	152	86
	32					

AERIAL FCC

2016.24.022.

FORCE DIAGRAM

shouldered

		Width 220 mm				
		50	50	20	50	50
Height 160 mm	32	69	154	307	154	69
	32	86	192	384	192	86
	32	103	231	460	231	103
	32	143	318	635	318	143
	32	89	198	396	198	89

		Width 220 mm				
		50	50	20	50	50
Height 160 mm	32	75	159	306	159	75
	32	95	201	390	201	95
	32	153	328	475	328	153
	32	107	218	648	218	107
	32	105	219	415	219	105

		Width 220 mm				
		50	50	20	50	50
Height 160 mm	32	79	162	305	162	79
	32	102	207	397	207	102
	32	117	228	489	228	117
	32	123	239	661	239	123
	32	121	240	435	240	121

		Width 220 mm				
		50	50	20	50	50
Height 160 mm	32	82	162	304	162	82
	32	109	212	404	212	109
	32	134	250	504	250	134
	32	139	260	674	260	139
	32	138	261	454	261	138

		Width 220 mm				
		50	50	20	50	50
Height 160 mm	32	85	162	302	162	85
	32	116	217	410	217	116
	32	151	271	518	271	151
	32	156	281	687	281	156
	32	154	282	473	282	154

		Width 220 mm				
		50	50	20	50	50
Height 160 mm	32	89	162	301	162	89
	32	123	222	417	222	123
	32	168	293	532	293	168
	32	172	301	700	301	172
	32	170	303	493	303	170

Support with feather key

		Width 220 mm				
		50	50	20	50	50
Height 160 mm	32	41	85	140	85	41
	32	52	106	140	106	52
	32	62	113	140	113	62
	32	67	113	140	113	67
	32	53	109	140	109	53

		Width 220 mm				
		50	50	20	50	50
Height 160 mm	32	45	87	153	87	45
	32	57	111	155	111	57
	32	69	119	155	119	69
	32	64	119	155	119	64
	32	63	119	155	119	63

		Width 220 mm				
		50	50	20	50	50
Height 160 mm	32	47	89	152	89	47
	32	61	114	156	114	61
	32	70	125	156	125	70
	32	74	131	156	131	74
	32	73	132	156	132	73

		Width 220 mm				
		50	50	20	50	50
Height 160 mm	32	49	89	152	89	49
	32	65	116	174	116	65
	32	72	137	174	137	72
	32	72	137	174	137	72
	32	72	137	174	137	72

		Width 220 mm				
		50	50	20	50	50
Height 160 mm	32	51	89	151	89	51
	32	69	119	196	119	69
	32	74	149	196	149	74
	32	74	154	196	154	74
	32	74	155	196	155	74

		Width 220 mm				
		50	50	20	50	50
Height 160 mm	32	53	89	151	89	53
	32	74	122	208	122	74
	32	86	152	208	152	86
	32	86	152	208	152	86
	32	86	152	208	152	86

AERIAL FCC

2016.24.022.

FORCE DIAGRAM

shouldered

Support with feather key

		Width 220 mm				
		50	50	20	50	50
30°	Height 160 mm	92	161	300	161	92
	32	130	227	423	227	130
	32	184	315	547	315	184
	32	188	322	714	322	188
	32	187	324	512	324	187
	32					

		Width 220 mm				
		50	50	20	50	50
30°	Height 160 mm	55	89	150	89	55
	32	78	125	212	125	78
	32	95	173	238	173	95
	32	95	177	238	177	95
	32	95	178	238	178	95
	32					

		Width 220 mm				
		50	50	20	50	50
35°	Height 160 mm	95	161	299	161	95
	32	137	232	430	232	137
	32	178	303	561	303	178
	32	268	454	727	454	268
	32	203	345	551	345	203
	32					

		Width 220 mm				
		50	50	20	50	50
35°	Height 160 mm	57	105	180	105	57
	32	82	151	258	151	82
	32	98	205	258	205	98
	32	98	205	258	205	98
	32	98	205	258	205	98
	32					

		Width 220 mm				
		50	50	20	50	50
40°	Height 160 mm	96	164	297	164	96
	32	138	236	427	236	138
	32	266	453	557	453	266
	32	204	347	727	347	204
	32	199	339	540	339	199
	32					

		Width 220 mm				
		50	50	20	50	50
40°	Height 160 mm	61	107	178	107	61
	32	87	153	256	153	87
	32	102	205	302	205	102
	32	102	205	302	205	102
	32	102	205	302	205	102
	32					

		Width 220 mm				
		50	50	20	50	50
45°	Height 160 mm	97	166	294	166	97
	32	140	239	424	239	140
	32	202	346	553	346	202
	32	200	341	728	341	200
	32	195	333	528	333	195
	32					

		Width 220 mm				
		50	50	20	50	50
45°	Height 160 mm	61	100	191	100	61
	32	88	144	275	144	88
	32	112	208	303	208	112
	32	115	205	308	205	115
	32	115	200	308	200	115
	32					

		Width 220 mm				
		50	50	20	50	50
50°	Height 160 mm	99	169	292	169	99
	32	142	243	420	243	142
	32	198	340	548	340	198
	32	195	335	729	335	195
	32	191	327	516	327	191
	32					

		Width 220 mm				
		50	50	20	50	50
50°	Height 160 mm	62	101	190	101	62
	32	90	146	273	146	90
	32	125	204	356	204	125
	32	123	201	360	201	123
	32	121	196	335	196	121
	32					

		Width 220 mm				
		50	50	20	50	50
55°	Height 160 mm	100	171	290	171	100
	32	144	247	417	247	144
	32	194	334	544	334	194
	32	191	329	729	329	191
	32	187	321	504	321	187
	32					

		Width 220 mm				
		50	50	20	50	50
55°	Height 160 mm	63	103	180	103	63
	32	91	148	334	148	91
	32	123	200	390	200	123
	32	121	197	390	197	121
	32	118	192	390	192	118
	32					

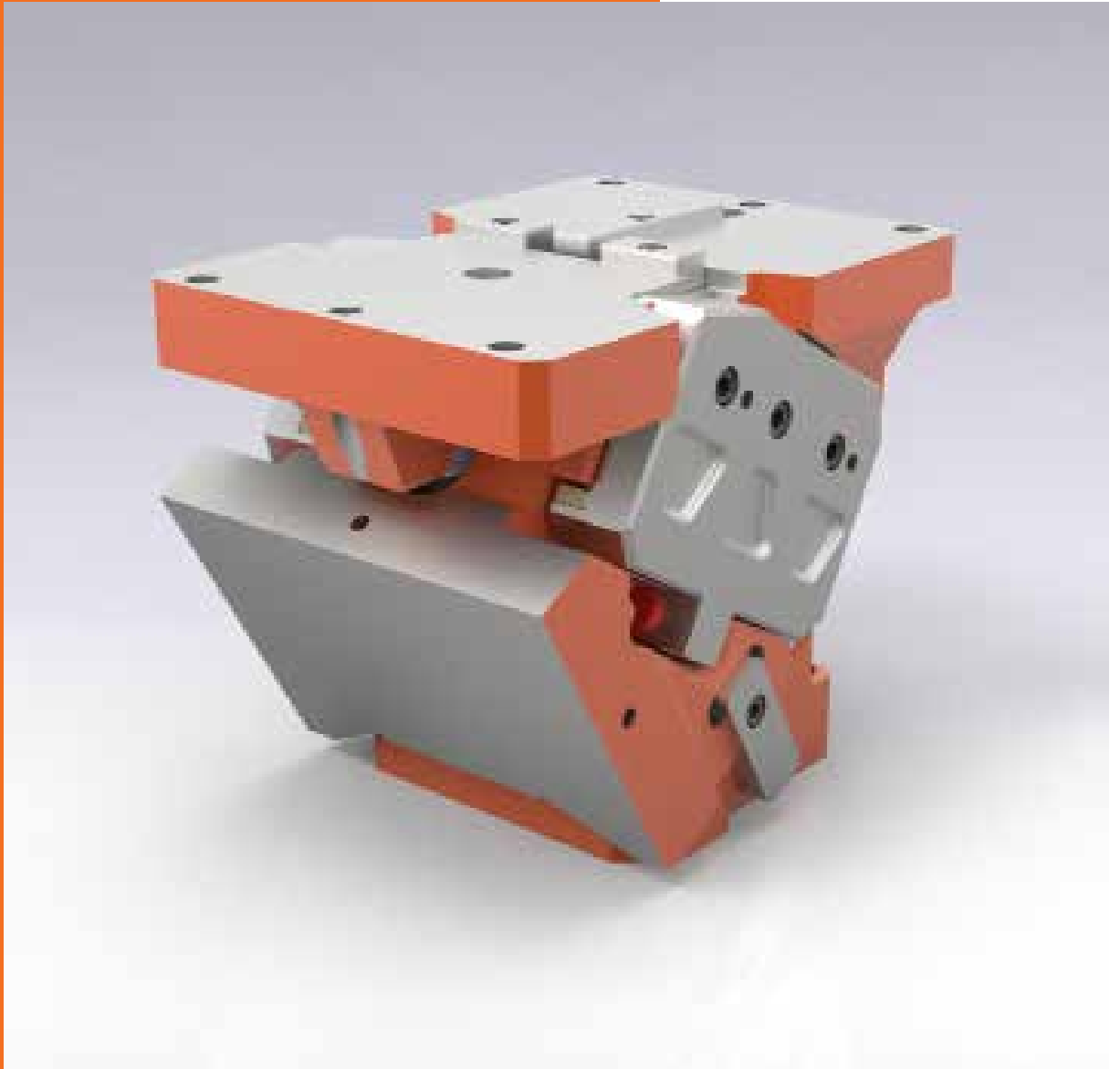

AERIAL FCC 2016.24.026.

Working width: 260 mm
Performance class: 650 kN

AERIAL FCC
2016.24.026.
 SIZE TABLE

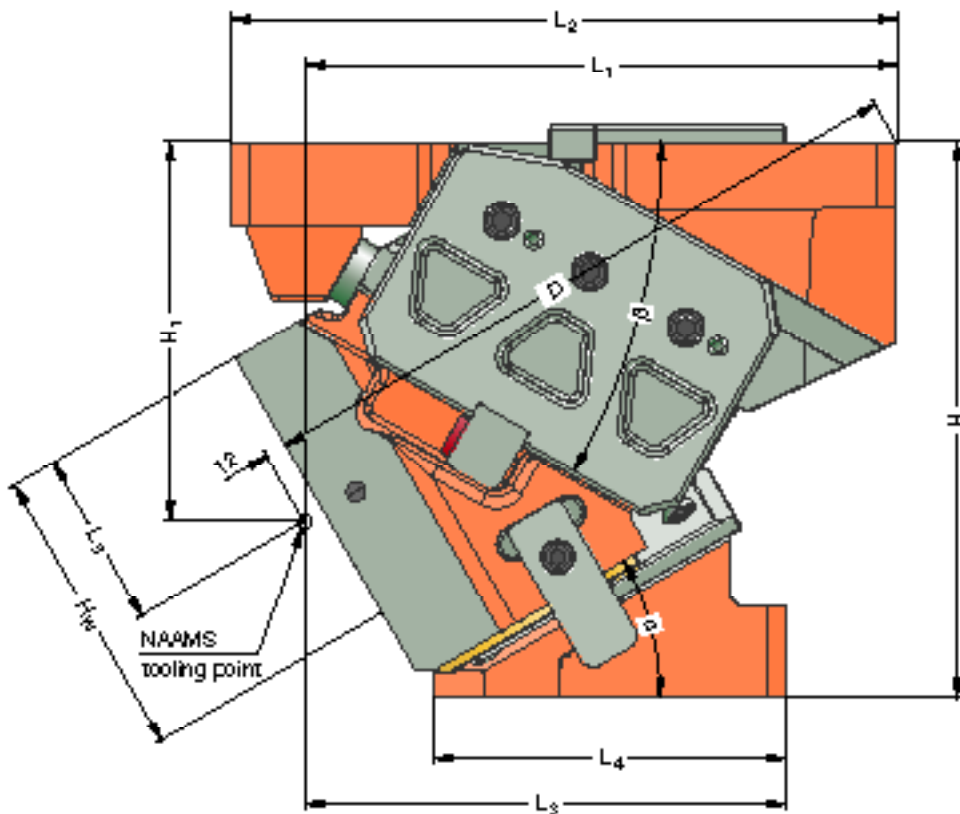
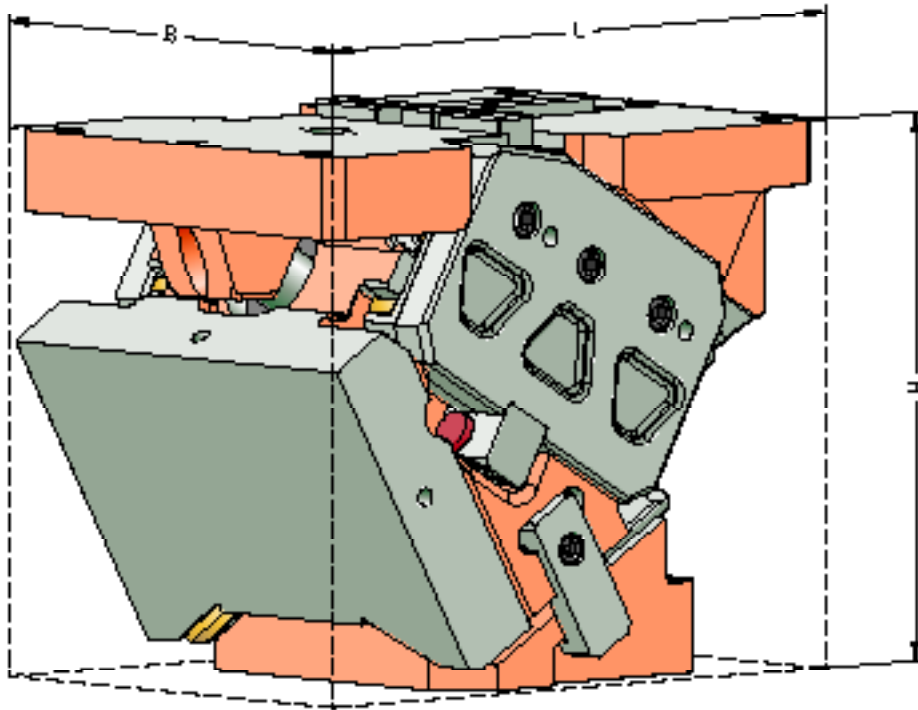

AERIAL FCC

2016.24.026.

SIZE TABLE

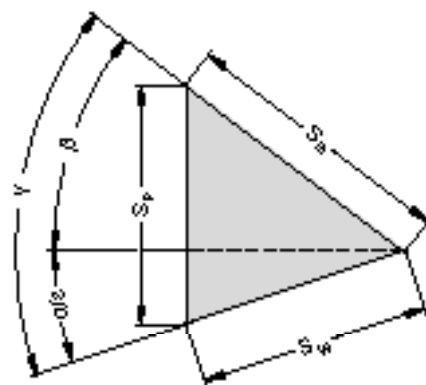

Order number	L [mm]	B [mm]	H [mm]	H ₁ [mm]	H _W [mm]	L ₁ [mm]	L ₂ [mm]	L ₃ [mm]	L ₄ [mm]	L ₅ [mm]	D [mm]	α [°]	β [°]	S _W * [mm]	S _S [mm]	S _P * [mm]
2016.24.026.00.1000.00	320	260	300	170	160	320	320	240	215	110	308.0	0	50	32.1	50	38.3
2016.24.026.05.1000.00	320	260	300	175	160	320	320	240	210	110	324.1	5	45	35.5	50	38.4
2016.24.026.10.1000.00	324	260	300	180	160	320	320	240	200	90	334.4	10	45	35.9	50	41.6
2016.24.026.15.1000.00	332	260	300	185	160	320	320	240	190	90	345.0	15	40	39.7	50	42.4
2016.24.026.20.1000.00	338	260	300	190	160	320	320	240	185	85	353.7	20	35	43.6	50	43.6
2016.24.026.25.1000.00	360	260	300	195	160	320	360	260	195	85	360.4	25	35	45.2	50	47.8
2016.24.026.30.1000.00	360	260	300	205	160	320	360	260	190	95	367.6	30	30	50.0	50	50.0
2016.24.026.35.1000.00	363	260	300	215	160	320	360	260	185	92	373.4	35	30	52.9	50	55.3
2016.24.026.40.1000.00	373	260	300	225	160	320	360	260	180	97	377.8	40	25	59.2	50	59.2
2016.24.026.45.1000.00	365	260	300	235	160	285	365	240	160	102	355.7	45	25	64.1	50	66.4
2016.24.026.50.1000.00	365	260	300	245	160	285	365	240	160	102	358.9	50	20	73.1	50	73.1
2016.24.026.55.1000.00	365	260	300	255	160	285	365	240	170	102	360.4	55	20	81.9	50	84.2
2016.24.026.60.1000.00	372	260	300	265	160	285	365	240	160	107	360.0	60	15	96.6	50	96.6
2016.24.026.65.1000.00	368	260	300	265	160	285	365	240	166	97	348.6	65	15	91.4	40	93.2
2016.24.026.70.1000.00	372	260	300	265	160	285	365	240	165	97	334.5	70	10	100.8	35	100.8
2016.24.026.75.1000.00	365	260	300	280	160	275	365	240	150	83	329.6	75	10	95.1	25	96.2

* Values rounded

Fastening cam base:

Hexagon socket head cap screws DIN EN ISO 4762
Dowel pins DIN EN ISO 8735

4x M16 / Strength class min. 8.8
2x \varnothing 16

Fastening cam driver :

Hexagon socket head cap screws DIN EN ISO 4762
Dowel pins DIN EN ISO 8735

4x M16 / Strength class min. 8.8
2x \varnothing 16

AERIAL FCC
2016.24.026.
EXPLODED VIEW

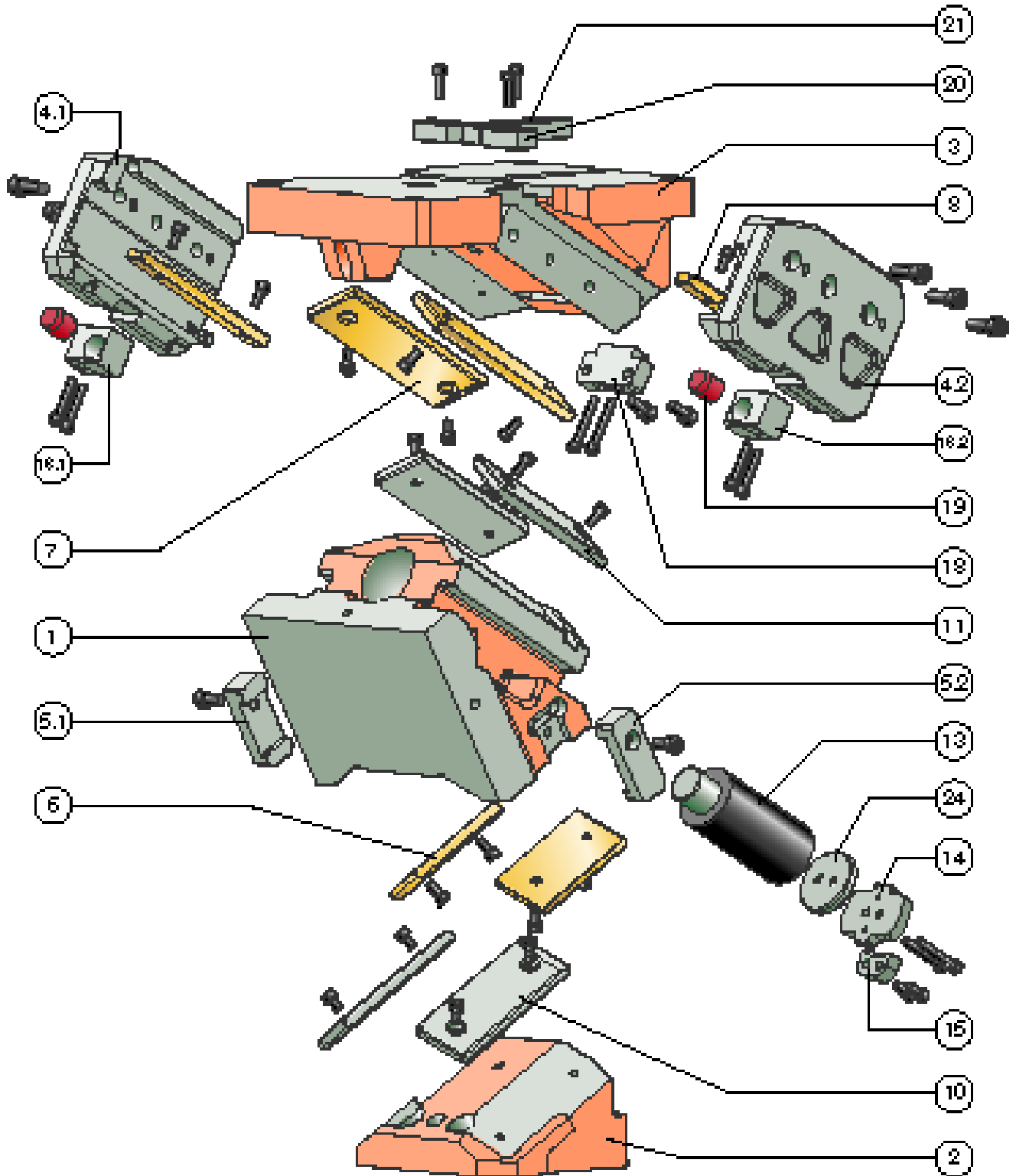

AERIAL FCC

2016.24.026.

PARTS LIST

Position	Piece	Designation	Material	spare part
1	1	Slider	GGG60	--
2	1	Cam driver	GGG60	--
2.1				
2.2				
3	1	Cam base	GGG60	--
4.1	1	Clamp, left	1.7225	x
4.2	1	Clamp, right	1.7225	x
5.1	1	Positive return, left	1.7225	x
5.2	1	Positive return, right	1.7225	x
6	2	Sliding plate	Bronze with solid lubricant	x
7	2	Sliding plate	Bronze with solid lubricant	x
8	2	Sliding plate	Bronze with solid lubricant	x
9				
10	2	Sliding plate	1.7131	x
11	2	Sliding plate	1.7131	x
12				
13	1	Gas spring	2487.12.01500.□□□	x
14	1	Stop plate	1.7225	x
15	1	Safety plate	1.1191	x
16.1	1	Cam slide stop, left	1.1191	x
16.2	1	Cam slide stop, right	1.1191	x
17				
18	1	Lockout system		x
19	2	Damping element	Elastomer	x
20	2	Feather key (T-nut)		x
21	1	Feather key (T-nut)		x
22				
23				
24	1	Spacer	1.1191	x

For inquiries or when ordering spare parts (x), we require the following data:

- ▶ Cam unit order no.
- ▶ Cam unit serial no.
- ▶ Item number / Designation / Spare part

AERIAL FCC

2016.24.026.

SYSTEM AND SURROUNDING FORCES

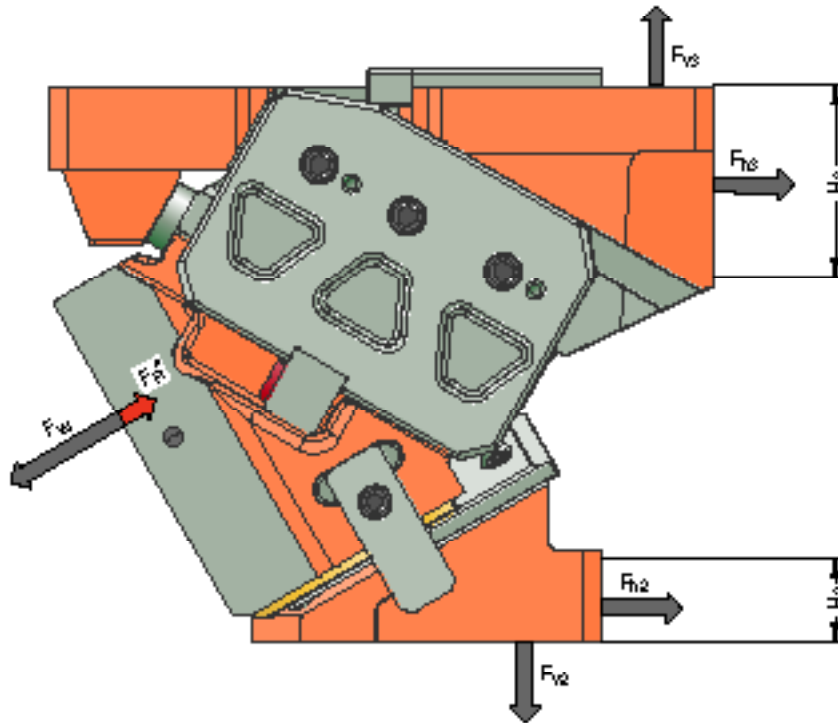

Order number	α [°]	F_W [kN]	F_R^* [kN]	F_{h2} [kN]	F_{v2} [kN]	F_{h3} [kN]	F_{v3} [kN]	H_2 [mm]	H_3 [mm]
2016.24.026.00.1000.00	0	536	24.9	0	450	536	450	25	160
2016.24.026.05.1000.00	5	564	25.1	41	471	521	521	32	138
2016.24.026.10.1000.00	10	593	27.6	72	409	512	512	35	138
2016.24.026.15.1000.00	15	621	27.8	113	420	487	581	40	112
2016.24.026.20.1000.00	20	650	27.9	156	428	455	650	40	89
2016.24.026.25.1000.00	25	673	31.3	164	352	446	637	40	123
2016.24.026.30.1000.00	30	690	31.4	199	345	398	690	40	108
2016.24.026.35.1000.00	35	708	36.2	189	270	391	677	38	114
2016.24.026.40.1000.00	40	737	36.4	221	263	344	737	40	92
2016.24.026.45.1000.00	45	744	43.4	191	191	335	718	50	82
2016.24.026.50.1000.00	50	747	43.5	208	175	272	747	50	65
2016.24.026.55.1000.00	55	751	54.5	165	115	266	731	60	65
2016.24.026.60.1000.00	60	755	54.6	175	101	202	755	60	61
2016.24.026.65.1000.00	65	759	60.0	121	57	199	744	70	57
2016.24.026.70.1000.00	70	763	60.0	126	46	135	763	70	46
2016.24.026.75.1000.00	75	767	60.0	65	17	134	758	70	46

* Retraction force values correspond to the spring-generated retraction force at the working point

The forces F_{h2} , F_{v2} as well as F_{h3} , F_{v3} act on the tool environment at maximum working force F_W .

AERIAL FCC

2016.24.026.

FORCE DIAGRAM

shouldered

		Width 260 mm						
		40	40	40	20	40	40	40
Height 160 mm	32	47	86	120	223	120	86	47
	32	61	111	159	295	159	111	61
	32	75	136	197	367	197	136	75
	32	104	188	272	536	272	188	104
	32	91	165	207	385	207	165	91

		Width 260 mm						
		40	40	40	20	40	40	40
Height 160 mm	32	48	84	120	234	120	84	48
	32	64	111	158	311	158	111	64
	32	79	137	195	388	195	137	79
	32	111	192	273	564	273	192	111
	32	98	170	241	410	241	170	98

		Width 260 mm						
		40	40	40	20	40	40	40
Height 160 mm	32	49	83	117	246	117	83	49
	32	66	110	155	328	155	110	66
	32	82	138	193	410	193	138	82
	32	117	195	273	593	273	195	117
	32	105	174	244	435	244	174	105

		Width 260 mm						
		40	40	40	20	40	40	40
Height 160 mm	32	50	82	113	257	113	82	50
	32	68	110	152	344	152	110	68
	32	86	139	191	432	191	139	86
	32	124	199	274	621	274	199	124
	32	112	179	246	460	246	179	112

		Width 260 mm						
		40	40	40	20	40	40	40
Height 160 mm	32	51	80	110	260	110	80	51
	32	70	110	150	355	150	110	70
	32	90	139	189	451	189	139	90
	32	130	202	274	650	274	202	130
	32	119	183	248	485	248	183	119

		Width 260 mm						
		40	40	40	20	40	40	40
Height 160 mm	32	52	79	106	258	106	79	52
	32	73	110	147	358	147	110	73
	32	93	140	187	458	187	140	93
	32	137	206	274	673	274	206	137
	32	125	188	250	510	250	188	125

Support with feather key

		Width 260 mm						
		40	40	40	20	40	40	40
Height 160 mm	32	45	69	108	156	108	69	45
	32	58	89	132	163	132	89	58
	32	72	109	132	163	132	109	72
	32	72	109	132	163	132	109	72
	32	72	109	132	163	132	109	72

		Width 260 mm						
		40	40	40	20	40	40	40
Height 160 mm	32	46	68	108	164	108	68	46
	32	60	89	142	178	142	89	60
	32	75	110	145	178	145	110	75
	32	75	110	145	178	145	110	75
	32	75	110	145	178	145	110	75

		Width 260 mm						
		40	40	40	20	40	40	40
Height 160 mm	32	47	66	105	172	105	66	47
	32	63	88	140	189	140	88	63
	32	78	110	148	189	148	110	78
	32	78	110	148	189	148	110	78
	32	78	110	148	189	148	110	78

		Width 260 mm						
		40	40	40	20	40	40	40
Height 160 mm	32	48	65	102	180	102	65	48
	32	65	88	137	221	137	88	65
	32	82	111	172	221	172	111	82
	32	82	111	172	221	172	111	82
	32	82	111	172	221	172	111	82

		Width 260 mm						
		40	40	40	20	40	40	40
Height 160 mm	32	50	66	101	185	101	66	50
	32	68	90	137	254	137	90	68
	32	87	114	174	254	174	114	87
	32	87	121	174	254	174	121	87
	32	87	121	174	254	174	121	87

		Width 260 mm						
		40	40	40	20	40	40	40
Height 160 mm	32	51	65	98	184	98	65	51
	32	70	90	135	256	135	90	70
	32	90	114	172	256	172	114	90
	32	90	123	172	256	172	123	90
	32	90	123	172	256	172	123	90

AERIAL FCC

2016.24.026.

FORCE DIAGRAM

shouldered

		Width 260 mm							
		40	40	40	20	40	40	40	
30°	Height 160 mm	32	53	78	103	256	103	78	53
		32	75	109	144	361	144	109	75
		32	97	141	186	465	186	141	97
		32	144	209	275	690	275	209	144
		32	132	192	253	535	253	192	132

		Width 260 mm							
		40	40	40	20	40	40	40	
35°	Height 160 mm	32	54	77	99	255	99	77	54
		32	77	109	141	364	141	109	77
		32	100	142	184	472	184	142	100
		32	150	213	275	708	275	213	150
		32	139	197	255	585	255	197	139

		Width 260 mm							
		40	40	40	20	40	40	40	
40°	Height 160 mm	32	55	78	100	256	100	78	55
		32	82	115	148	379	148	115	82
		32	110	153	197	502	197	153	110
		32	160	224	289	737	289	224	160
		32	140	197	254	585	254	197	140

		Width 260 mm							
		40	40	40	20	40	40	40	
45°	Height 160 mm	32	57	79	101	257	101	79	57
		32	88	122	155	394	155	122	88
		32	119	164	210	532	210	164	119
		32	170	236	302	744	302	236	170
		32	142	197	253	586	253	197	142

		Width 260 mm							
		40	40	40	20	40	40	40	
50°	Height 160 mm	32	93	128	162	410	162	128	93
		32	128	176	223	561	223	176	128
		32	181	248	315	747	315	248	181
		32	143	198	252	587	252	198	143
		32	119	183	248	485	248	183	119

		Width 260 mm							
		40	40	40	20	40	40	40	
55°	Height 160 mm	32	59	81	102	258	102	81	59
		32	98	134	169	425	169	134	98
		32	138	187	236	575	236	187	138
		32	191	260	328	751	328	260	191
		32	145	198	251	587	251	198	145

Support with feather key

		Width 260 mm							
		40	40	40	20	40	40	40	
30°	Height 160 mm	32	51	64	94	183	94	64	51
		32	73	89	132	258	132	89	73
		32	94	115	170	275	170	115	94
		32	94	132	189	275	189	132	94
		32	94	132	189	275	189	132	94

		Width 260 mm							
		40	40	40	20	40	40	40	
35°	Height 160 mm	32	52	63	91	182	91	63	52
		32	75	89	130	260	130	89	75
		32	97	116	169	262	169	116	97
		32	97	161	210	262	210	161	97
		32	97	161	210	262	210	161	97

		Width 260 mm							
		40	40	40	20	40	40	40	
40°	Height 160 mm	32	54	63	92	183	92	63	54
		32	80	94	136	271	136	94	80
		32	106	125	181	359	181	125	106
		32	106	161	233	359	233	161	106
		32	106	161	233	359	233	161	106

		Width 260 mm							
		40	40	40	20	40	40	40	
45°	Height 160 mm	32	57	66	95	205	95	66	57
		32	88	102	147	316	147	102	88
		32	119	138	199	363	199	138	119
		32	119	199	286	365	286	199	119
		32	119	166	240	365	240	166	119

		Width 260 mm							
		40	40	40	20	40	40	40	
50°	Height 160 mm	32	58	67	96	206	96	67	58
		32	93	108	154	328	154	108	93
		32	128	148	211	449	211	148	128
		32	128	209	298	449	298	209	128
		32	128	166	239	449	239	166	128

		Width 260 mm							
		40	40	40	20	40	40	40	
55°	Height 160 mm	32	59	68	97	219	97	68	59
		32	98	113	160	362	160	113	98
		32	138	157	224	454	224	157	138
		32	145	219	311	460	311	219	145
		32	145	167	238	460	238	167	145

AERIAL FCC

2016.24.026.

FORCE DIAGRAM

shouldered

		Width 260 mm						
		40	40	40	20	40	40	40
Height 160 mm	32	60	82	103	259	103	82	60
	32	104	140	176	441	176	140	104
	32	147	198	249	589	249	198	147
	32	201	271	342	755	342	271	201
	32	146	198	250	588	250	198	146

Support with feather key

		Width 260 mm						
		40	40	40	20	40	40	40
Height 160 mm	32	60	69	98	220	98	69	60
	32	104	118	167	375	167	118	104
	32	147	167	236	501	236	167	147
	32	147	205	293	600	293	205	147
	32	146	167	237	500	237	167	146

65°

		Width 260 mm						
		40	40	40	20	40	40	40
Height 160 mm	32	62	83	104	260	104	83	62
	32	109	146	183	453	183	146	109
	32	156	209	262	603	262	209	156
	32	211	283	355	759	355	283	211
	32	147	198	249	588	249	198	147

65°

		Width 260 mm						
		40	40	40	20	40	40	40
Height 160 mm	32	62	70	99	247	99	70	62
	32	109	123	174	430	174	123	109
	32	156	176	248	573	248	176	156
	32	156	238	336	580	336	238	156
	32	147	167	236	559	236	167	147

70°

		Width 260 mm						
		40	40	40	20	40	40	40
Height 160 mm	32	63	84	105	261	105	84	63
	32	114	152	190	460	190	152	114
	32	166	221	275	617	275	221	166
	32	221	295	368	763	368	295	221
	32	149	198	248	589	248	198	149

70°

		Width 260 mm						
		40	40	40	20	40	40	40
Height 160 mm	32	63	71	99	248	99	71	63
	32	114	128	180	437	180	128	114
	32	166	186	261	587	261	186	166
	32	150	248	349	725	349	248	150
	32	149	167	235	560	235	167	149

75°

		Width 260 mm						
		40	40	40	20	40	40	40
Height 160 mm	32	64	85	106	261	106	85	64
	32	120	158	197	467	197	158	120
	32	175	232	288	632	288	232	175
	32	232	306	381	767	381	306	232
	32	150	199	247	590	247	199	150

75°

		Width 260 mm						
		40	40	40	20	40	40	40
Height 160 mm	32	64	72	100	261	100	72	64
	32	120	133	187	467	187	133	120
	32	175	195	273	632	273	195	175
	32	175	258	361	767	361	258	175
	32	150	167	234	590	234	167	150

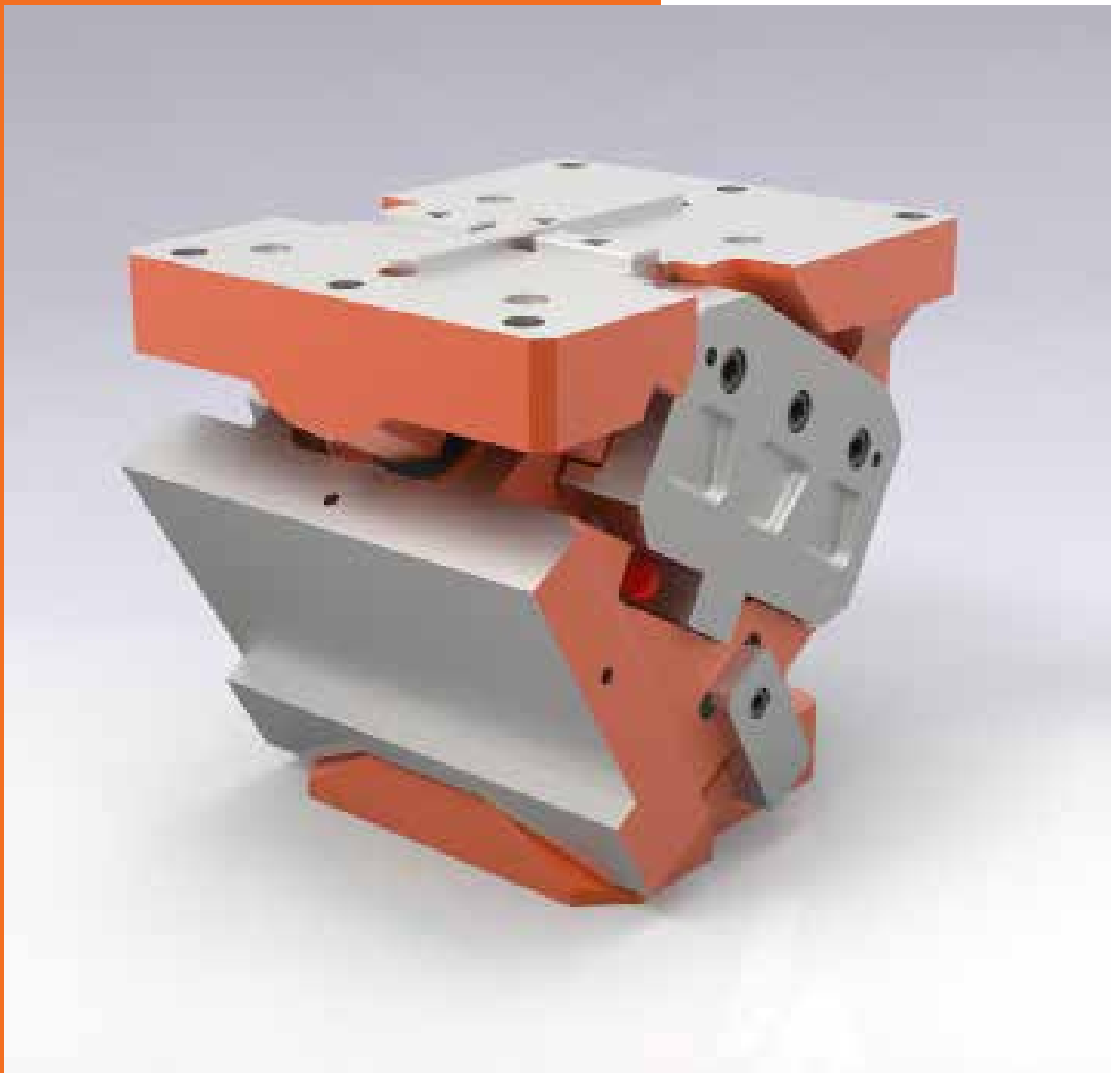

AERIAL FCC 2016.24.033.

Working width: 330 mm
Performance class: 1000 kN

AERIAL FCC
2016.24.033.
 SIZE TABLE

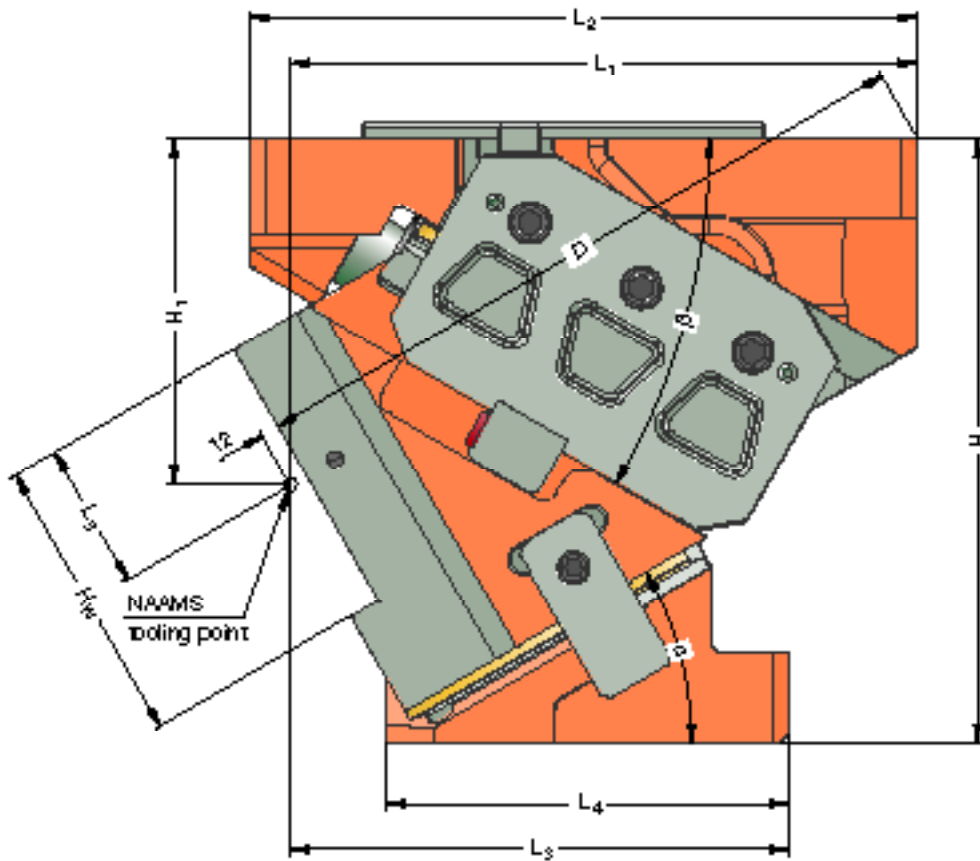
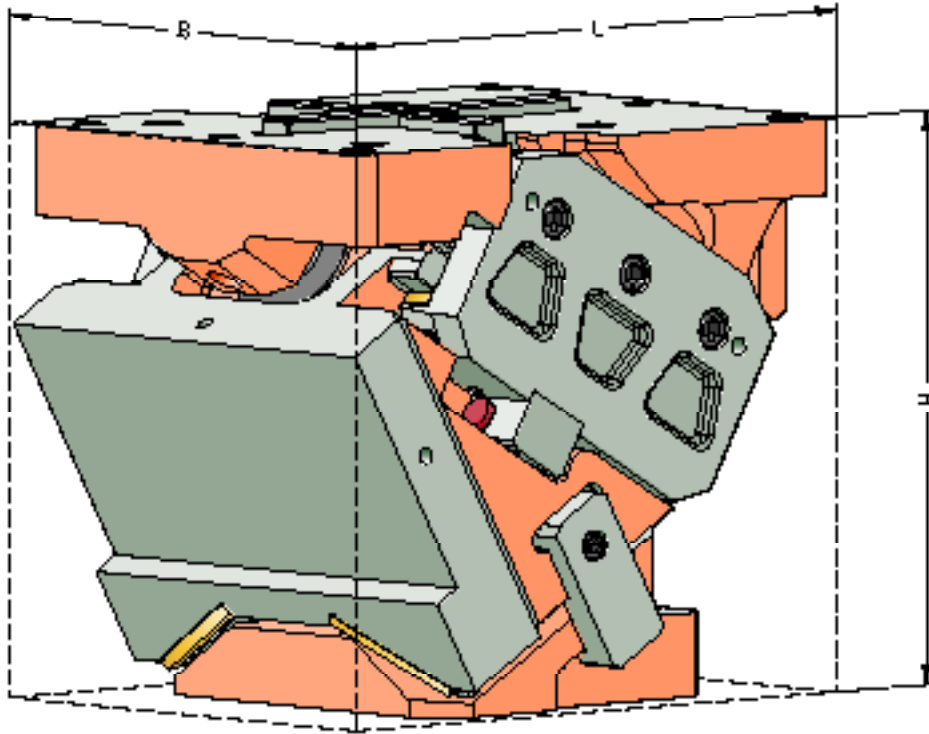

AERIAL FCC 2016.24.033. SIZE TABLE

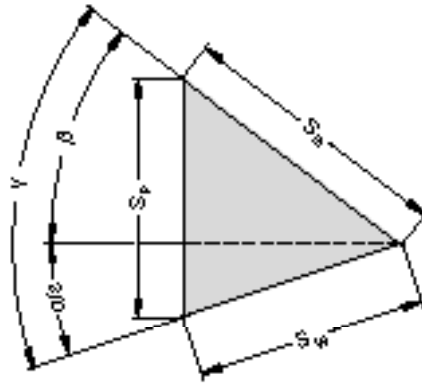

Order number	L [mm]	B [mm]	H [mm]	H ₁ [mm]	H _W [mm]	L ₁ [mm]	L ₂ [mm]	L ₃ [mm]	L ₄ [mm]	L ₅ [mm]	D [mm]	α [°]	β [°]	S _W * [mm]	S _S [mm]	S _P * [mm]
2016.24.033.00.2000.00	415	330	375	415	180	403	415	285	280	105	403.0	0	50	37.3	58	44.4
2016.24.033.05.2000.00	415	330	375	185	180	415	415	285	268	90	417.5	5	45	41.2	58	44.6
2016.24.033.10.2000.00	419	330	375	190	180	415	415	285	254	90	429.7	10	45	41.6	58	48.2
2016.24.033.15.2000.00	427	330	375	195	180	415	415	285	255	90	439.3	15	40	46.0	58	49.2
2016.24.033.20.2000.01	434.5	330	375	200	180	415	415	285	245	90	446.4	20	35	50.6	58	50.6
2016.24.033.25.2000.00	417	330	375	205	180	390	415	310	259	90	428.1	25	35	52.4	58	55.4
2016.24.033.30.2000.00	425	330	375	215	180	390	415	310	250	90	433.3	30	30	58.0	58	58.0
2016.24.033.35.2000.00	428	330	375	225	180	390	415	310	237	83	436.5	35	30	61.3	58	64.2
2016.24.033.40.2000.00	439	330	375	235	180	390	415	310	232	90	437.8	40	25	68.6	58	68.6
2016.24.033.45.2000.00	450	330	375	245	180	340	450	310	225	90	401.7	45	25	74.3	58	77.1
2016.24.033.50.2000.00	450	330	375	265	180	340	450	310	222	105	409.6	50	20	84.8	58	84.8
2016.24.033.55.2000.00	450	330	375	285	180	340	450	310	226	110	416.5	55	20	95.0	58	97.7
2016.24.033.60.2000.00	450	330	375	300	180	340	450	310	228	115	418.0	60	15	112.0	58	112.0
2016.24.033.65.2000.00	450	330	375	300	180	340	450	340	242	110	403.6	65	15	102.9	45	104.9
2016.24.033.70.2000.00	450	330	375	300	180	340	450	340	232	100	386.2	70	15	127.1	45	131.1
2016.24.033.75.2000.00	450	330	375	300	180	325	450	325	221	100	361.9	75	10	114.2	30	115.5

* Values rounded

Fastening cam base:

Hexagon socket head cap screws DIN EN ISO 4762
Dowel pins DIN EN ISO 8735

4x M20 / Strength class min. 8.8
2x Ø20

Fastening cam driver :

Hexagon socket head cap screws DIN EN ISO 4762
Dowel pins DIN EN ISO 8735

4x M20 / Strength class min. 8.8
2x Ø20

AERIAL FCC
2016.24.033.
 EXPLODED VIEW

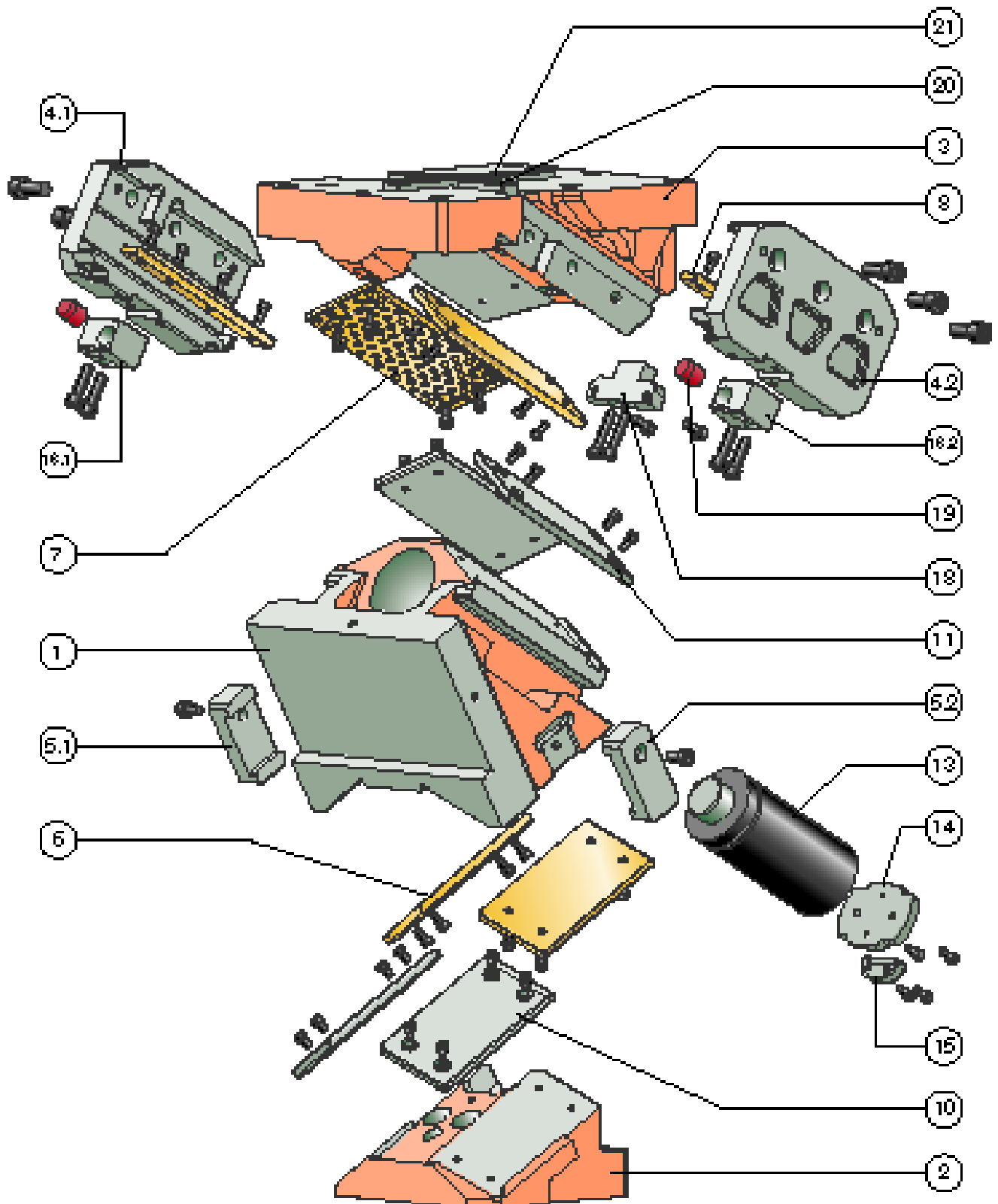

AERIAL FCC

2016.24.033.

PARTS LIST

Position	Piece	Designation	Material	spare part
1	1	Slider	GGG60	--
2	1	Cam driver	GGG60	--
2.1				
2.2				
3	1	Cam base	GGG60	--
4.1	1	Clamp, left	1.7225	x
4.2	1	Clamp, right	1.7225	x
5.1	1	Positive return, left	1.7225	x
5.2	1	Positive return, right	1.7225	x
6	2	Sliding plate	Bronze with solid lubricant	x
7	2	Sliding plate	Bronze with solid lubricant	x
8	2	Sliding plate	Bronze with solid lubricant	x
9				
10	2	Sliding plate	1.7131	x
11	2	Sliding plate	1.7131	x
12				
13	1	Gas spring	2487.12.03000.□□□	x
14	1	Stop plate	1.7225	x
15	1	Safety plate	1.1191	x
16.1	1	Cam slide stop, left	1.1191	x
16.2	1	Cam slide stop, right	1.1191	x
17				
18	1	Lockout system		x
19	2	Damping element	Elastomer	x
20	2	Feather key (T-nut)		x
21	1	Feather key (T-nut)		x
22				
23				
24				

For inquiries or when ordering spare parts (x), we require the following data:

- ▶ Cam unit order no.
- ▶ Cam unit serial no.
- ▶ Item number / Designation / Spare part

AERIAL FCC

2016.24.033.

SYSTEM AND SURROUNDING FORCES

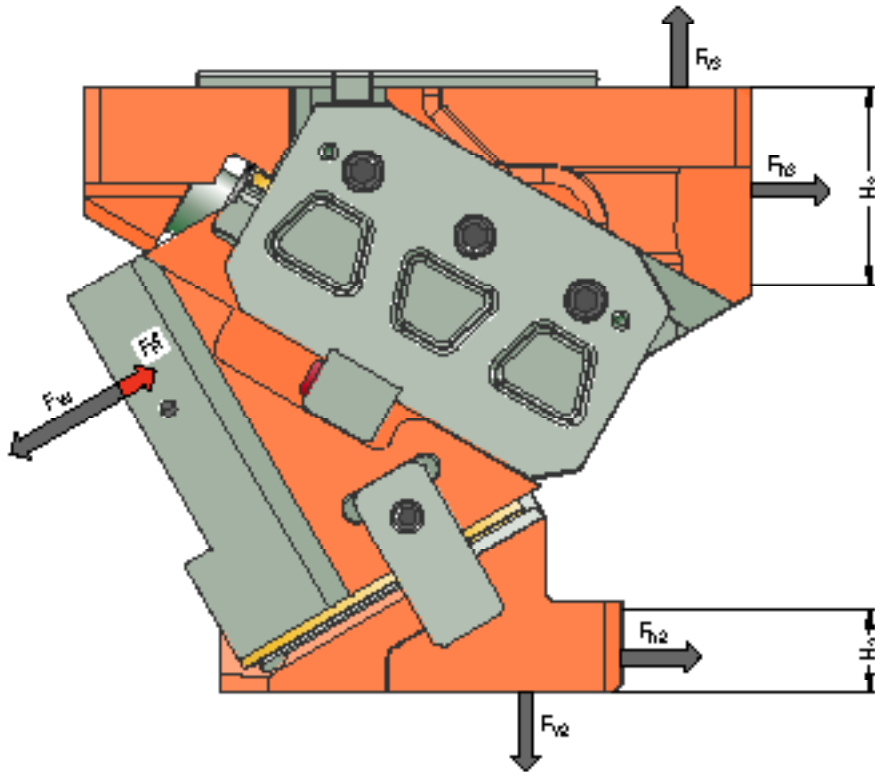

Order number	α [°]	F_W [kN]	F_R^* [kN]	F_{h2} [kN]	F_{v2} [kN]	F_{h3} [kN]	F_{v3} [kN]	H_2 [mm]	H_3 [mm]
2016.24.033.00.2000.00	0	1006	53.3	0	844	1006	844	40	162
2016.24.033.05.2000.00	5	1005	53.6	73	840	928	928	40	164
2016.24.033.10.2000.00	10	1005	59.0	122	693	868	868	40	163
2016.24.033.15.2000.00	15	1005	59.3	182	680	789	940	40	139
2016.24.033.20.2000.01	20	1007	63.3	241	663	705	1007	40	125
2016.24.033.25.2000.00	25	1009	67.0	246	528	668	954	40	145
2016.24.033.30.2000.00	30	1010	67.2	292	505	583	1010	40	126
2016.24.033.35.2000.00	35	1012	77.5	271	387	558	967	40	127
2016.24.033.40.2000.00	40	1013	77.8	304	362	472	1013	40	117
2016.24.033.45.2000.00	45	1014	92.8	261	261	456	978	50	140
2016.24.033.50.2000.00	50	1015	93.1	283	237	369	1015	50	120
2016.24.033.55.2000.00	55	1016	95.0	223	156	360	988	60	120
2016.24.033.60.2000.00	60	1017	100.0	236	136	273	1017	70	114
2016.24.033.65.2000.00	65	1018	100.0	163	76	268	998	32	100
2016.24.033.70.2000.00	70	1019	100.0	84	30	265	988	32	99
2016.24.033.75.2000.00	75	1020	100.0	86	23	178	1008	32	73

* Retraction force values correspond to the spring-generated retraction force at the working point

The forces F_{h2} , F_{v2} as well as F_{h3} , F_{v3} act on the tool environment at maximum working force F_W .

AERIAL FCC

2016.24.033.

FORCE DIAGRAM

shouldered

		Width 330 mm							
		50	50	50	30	50	50	50	
Height 180 mm	0°	36	87	174	261	499	261	174	87
	36	36	118	237	355	679	355	237	118
	36	36	150	300	449	858	449	300	150
	36	36	177	354	531	1001	531	354	177
	36	36	176	351	527	1006	527	351	176

		Width 330 mm							
		50	50	50	30	50	50	50	
Height 180 mm	5°	36	86	172	259	492	259	172	86
	36	36	120	240	360	684	360	240	120
	36	36	153	307	461	876	461	307	153
	36	36	179	358	537	1002	537	358	179
	36	36	178	357	535	1005	535	357	178

		Width 330 mm							
		50	50	50	30	50	50	50	
Height 180 mm	10°	36	85	171	256	486	256	171	85
	36	36	121	243	364	690	364	243	121
	36	36	157	315	472	894	472	315	157
	36	36	181	362	543	1004	543	362	181
	36	36	181	362	543	1005	543	362	181

		Width 330 mm							
		50	50	50	30	50	50	50	
Height 180 mm	15°	36	84	169	254	479	254	169	84
	36	36	123	246	368	696	368	246	123
	36	36	161	322	483	912	483	322	161
	36	36	183	366	549	1005	549	366	183
	36	36	183	367	551	1005	551	367	183

		Width 330 mm							
		50	50	50	30	50	50	50	
Height 180 mm	20°	36	84	167	251	473	251	167	84
	36	36	124	248	373	702	373	248	124
	36	36	164	330	495	930	495	330	164
	36	36	185	370	555	1007	555	370	185
	36	36	186	372	558	1005	558	372	186

		Width 330 mm							
		50	50	50	30	50	50	50	
Height 180 mm	25°	36	83	166	249	466	249	166	83
	36	36	125	251	377	707	377	251	125
	36	36	168	337	506	948	506	337	168
	36	36	186	374	561	1009	561	374	186
	36	36	188	377	566	1004	566	377	188

Support with feather key

		Width 330 mm							
		50	50	50	30	50	50	50	
Height 180 mm	0°	36	67	96	115	129	115	96	67
	36	36	67	96	115	129	115	96	67
	36	36	67	96	115	129	115	96	67
	36	36	67	96	115	129	115	96	67
	36	36	67	96	115	129	115	96	67

		Width 330 mm							
		50	50	50	30	50	50	50	
Height 180 mm	5°	36	82	95	116	143	116	95	82
	36	36	82	97	116	143	116	97	82
	36	36	82	97	116	143	116	97	82
	36	36	82	97	116	143	116	97	82
	36	36	82	97	116	143	116	97	82

		Width 330 mm							
		50	50	50	30	50	50	50	
Height 180 mm	10°	36	79	85	115	156	115	85	79
	36	36	79	99	120	156	120	99	79
	36	36	79	99	120	156	120	99	79
	36	36	79	100	120	156	120	100	79
	36	36	79	100	120	156	120	100	79

		Width 330 mm							
		50	50	50	30	50	50	50	
Height 180 mm	15°	36	80	85	114	168	114	85	80
	36	36	80	100	122	168	122	100	80
	36	36	80	100	122	168	122	100	80
	36	36	80	100	122	168	122	100	80
	36	36	80	100	122	168	122	100	80

		Width 330 mm							
		50	50	50	30	50	50	50	
Height 180 mm	20°	36	81	84	113	166	113	84	81
	36	36	81	116	148	187	148	116	81
	36	36	81	116	148	187	148	116	81
	36	36	81	116	148	187	148	116	81
	36	36	81	116	148	187	148	116	81

		Width 330 mm							
		50	50	50	30	50	50	50	
Height 180 mm	25°	36	80	83	112	163	112	83	80
	36	36	80	126	154	208	154	126	80
	36	36	80	126	154	208	154	126	80
	36	36	80	126	154	208	154	126	80
	36	36	80	126	154	208	154	126	80

AERIAL FCC

2016.24.033.

FORCE DIAGRAM

shouldered

		Width 330 mm							
		50	50	50	30	50	50	50	
30°	Height 180 mm	36	82	164	246	460	246	164	82
		36	127	254	382	713	382	254	127
		36	172	344	517	966	517	344	172
		36	188	378	567	1010	567	378	188
		36	191	382	574	1004	574	382	191

Support with feather key

		Width 330 mm							
		50	50	50	30	50	50	50	
30°	Height 180 mm	36	82	111	161	111	82	79	67
		36	127	172	225	172	127	85	67
		36	133	172	225	172	133	85	67
		36	133	172	225	172	133	85	67
		36	133	172	225	172	133	85	67

35°

		Width 330 mm							
		50	50	50	30	50	50	50	
35°	Height 180 mm	36	81	162	244	453	244	162	81
		36	128	257	386	719	386	257	128
		36	175	352	528	984	528	352	175
		36	190	382	573	1012	573	382	190
		36	193	387	582	1004	582	387	193

35°

		Width 330 mm							
		50	50	50	30	50	50	50	
35°	Height 180 mm	36	78	114	151	197	151	114	78
		36	78	127	167	227	167	127	78
		36	81	128	169	227	169	128	81
		36	83	135	175	236	175	135	83
		36	82	131	171	234	171	131	82

40°

		Width 330 mm							
		50	50	50	30	50	50	50	
40°	Height 180 mm	36	81	161	241	443	241	161	81
		36	131	259	387	711	387	259	131
		36	180	357	534	979	534	357	180
		36	200	396	592	1013	592	396	200
		36	200	396	592	1003	592	396	200

40°

		Width 330 mm							
		50	50	50	30	50	50	50	
40°	Height 180 mm	36	79	89	121	177	121	89	79
		36	99	142	194	285	194	142	99
		36	99	157	194	285	194	157	99
		36	99	157	194	285	194	157	99
		36	99	157	194	285	194	157	99

45°

		Width 330 mm							
		50	50	50	30	50	50	50	
45°	Height 180 mm	36	81	160	239	433	239	160	81
		36	133	261	389	704	389	261	133
		36	185	362	539	975	539	362	185
		36	210	411	612	1014	612	411	210
		36	207	405	603	1003	603	405	207

45°

		Width 330 mm							
		50	50	50	30	50	50	50	
45°	Height 180 mm	36	81	96	131	195	131	96	81
		36	112	157	214	293	214	157	112
		36	112	168	245	293	245	168	112
		36	112	168	245	293	245	168	112
		36	112	168	245	293	245	168	112

50°

		Width 330 mm							
		50	50	50	30	50	50	50	
50°	Height 180 mm	36	82	159	236	423	236	159	82
		36	135	263	390	697	390	263	135
		36	189	367	544	970	544	367	189
		36	220	426	631	1015	631	426	220
		36	213	413	613	1003	613	413	213

50°

		Width 330 mm							
		50	50	50	30	50	50	50	
50°	Height 180 mm	36	82	95	130	190	130	95	82
		36	128	158	215	314	215	158	128
		36	128	175	250	362	250	175	128
		36	128	175	250	362	250	175	128
		36	128	175	250	362	250	175	128

55°

		Width 330 mm							
		50	50	50	30	50	50	50	
55°	Height 180 mm	36	82	158	234	413	234	158	82
		36	138	265	392	689	392	265	138
		36	194	372	550	966	550	372	194
		36	230	440	650	1016	650	440	230
		36	220	422	623	1002	623	422	220

55°

		Width 330 mm							
		50	50	50	30	50	50	50	
55°	Height 180 mm	36	82	100	129	207	129	100	82
		36	138	167	216	345	216	167	138
		36	138	208	265	383	265	208	138
		36	138	208	265	383	265	208	138
		36	138	208	265	383	265	208	138

AERIAL FCC

2016.24.033.

FORCE DIAGRAM

shouldered

		Width 330 mm							
		50	50	50	30	50	50	50	
Height 180 mm	60°	36	82	157	232	403	232	157	82
	36	140	267	393	682	393	267	140	
	36	198	377	555	961	555	377	198	
	36	240	455	669	1017	669	455	240	
	36	227	430	634	1002	634	430	227	

Support with feather key

		Width 330 mm							
		50	50	50	30	50	50	50	
Height 180 mm	60°	36	82	99	127	202	127	99	82
	36	140	168	216	341	216	168	140	
	36	158	237	305	481	305	237	158	
	36	158	237	348	481	348	237	158	
	36	158	237	348	481	348	237	158	

65°

		Width 330 mm						
		50	50	50	30	50	50	50
Height 180 mm	36	83	156	229	393	229	156	83
	36	143	269	395	675	395	269	143
	36	203	382	560	957	560	382	203
	36	250	469	689	1018	689	469	250
	36	233	439	644	1001	644	439	233

65°

		Width 330 mm						
		50	50	50	30	50	50	50
Height 180 mm	36	83	98	138	216	138	98	83
	36	143	169	237	371	237	169	143
	36	173	240	336	482	336	240	173
	36	173	265	350	495	350	265	173
	36	173	265	350	495	350	265	173

70°

		Width 330 mm						
		50	50	50	30	50	50	50
Height 180 mm	36	83	155	227	383	227	155	83
	36	145	271	396	668	396	271	145
	36	207	387	566	952	566	387	207
	36	260	484	708	1019	708	484	260
	36	240	447	654	1001	654	447	240

70°

		Width 330 mm						
		50	50	50	30	50	50	50
Height 180 mm	36	83	119	163	268	163	119	83
	36	145	209	285	467	285	209	145
	36	200	272	372	497	372	272	200
	36	200	272	382	505	382	272	200
	36	200	272	382	508	382	272	200

75°

		Width 330 mm						
		50	50	50	30	50	50	50
Height 180 mm	36	83	154	225	373	225	154	83
	36	148	273	398	660	398	273	148
	36	212	391	571	948	571	391	212
	36	270	499	727	1020	727	499	270
	36	247	456	665	1001	665	456	247

75°

		Width 330 mm						
		50	50	50	30	50	50	50
Height 180 mm	36	83	119	162	261	162	119	83
	36	148	210	286	462	286	210	148
	36	212	301	411	663	411	301	212
	36	270	384	524	714	524	384	270
	36	247	351	479	700	479	351	247



AERIAL FCC 2016.24.040.

Working width: 400 mm
Performance class: 1050 kN

AERIAL FCC
2016.24.040.
 SIZE TABLE

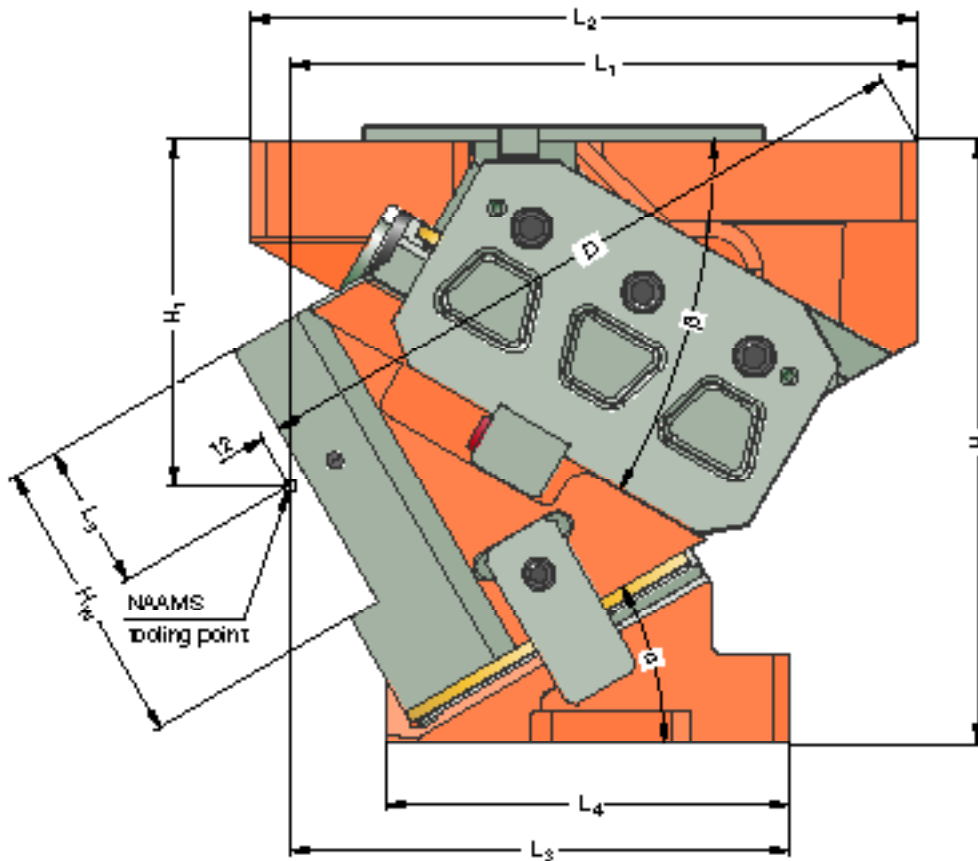
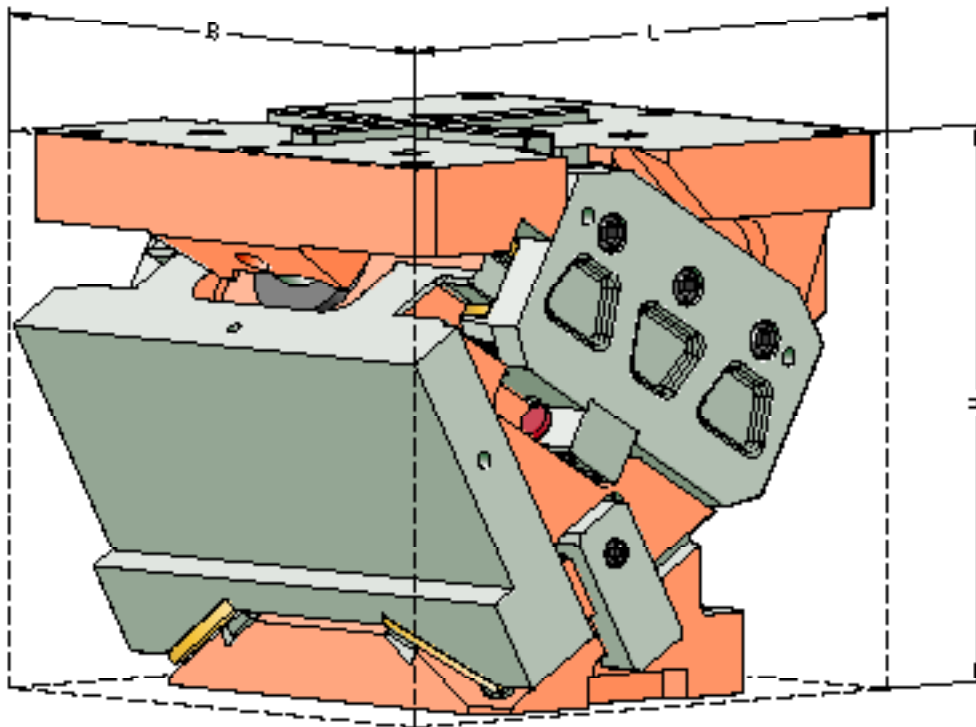

AERIAL FCC

2016.24.040.

SIZE TABLE

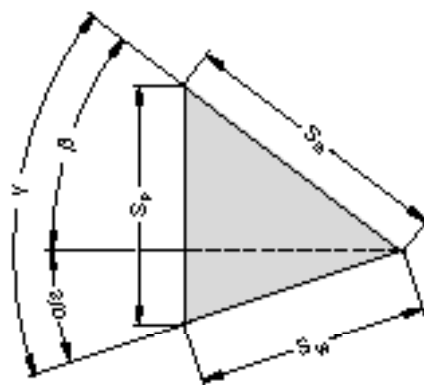

Order number	L [mm]	B [mm]	H [mm]	H ₁ [mm]	H _W [mm]	L ₁ [mm]	L ₂ [mm]	L ₃ [mm]	L ₄ [mm]	L ₅ [mm]	D [mm]	α [°]	β [°]	S _W * [mm]	S _S [mm]	S _P * [mm]
2016.24.040.00.2000.00	415	400	375	185	180	415	415	285	280	105	403.0	0	50	37.3	58	44.4
2016.24.040.05.2000.00	415	400	375	185	180	415	415	285	280	90	417.5	5	45	41.2	58	44.6
2016.24.040.10.2000.00	419	400	375	190	180	415	415	285	255	90	429.7	10	45	41.6	58	48.2
2016.24.040.15.2000.00	427	400	375	195	180	415	415	285	255	90	439.3	15	40	46.0	58	49.2
2016.24.040.20.2000.01	434.5	400	375	200	180	415	415	285	245	90	446.4	20	35	50.6	58	50.6
2016.24.040.25.2000.00	417	400	375	205	180	390	415	310	260	90	428.1	25	35	52.4	58	55.4
2016.24.040.30.2000.00	425	400	375	215	180	390	415	310	250	90	433.3	30	30	58.0	58	58.0
2016.24.040.35.2000.00	428	400	375	225	180	390	415	310	237	83	436.5	35	30	61.3	58	64.2
2016.24.040.40.2000.00	439	400	375	235	180	390	415	310	230	90	437.8	40	25	68.6	58	68.6
2016.24.040.45.2000.00	450	400	375	245	180	340	450	310	225	90	401.7	45	25	74.3	58	77.1
2016.24.040.50.2000.00	450	400	375	265	180	340	450	310	215	105	409.6	50	20	84.8	58	84.8
2016.24.040.55.2000.00	450	400	375	285	180	340	450	310	226	110	416.5	55	20	95.0	58	97.7
2016.24.040.60.2000.00	450	400	375	300	180	340	450	310	230	115	417.8	60	15	112.0	58	112.0
2016.24.040.65.2000.00	450	400	375	300	180	340	450	340	242	110	403.6	65	15	102.9	45	104.9
2016.24.040.70.2000.00	450	400	375	300	180	340	450	340	226	100	386.2	70	15	127.1	45	131.1
2016.24.040.75.2000.00	450	400	375	300	180	325	450	325	214	100	361.9	75	10	114.2	30	115.5

* Values rounded

Fastening cam base:

Hexagon socket head cap screws DIN EN ISO 4762
Dowel pins DIN EN ISO 8735

4x M20 / Strength class min. 8.8
2x Ø20

Fastening cam driver :

Hexagon socket head cap screws DIN EN ISO 4762
Dowel pins DIN EN ISO 8735

4x M20 / Strength class min. 8.8
2x Ø20

AERIAL FCC
2016.24.040.
 EXPLODED VIEW

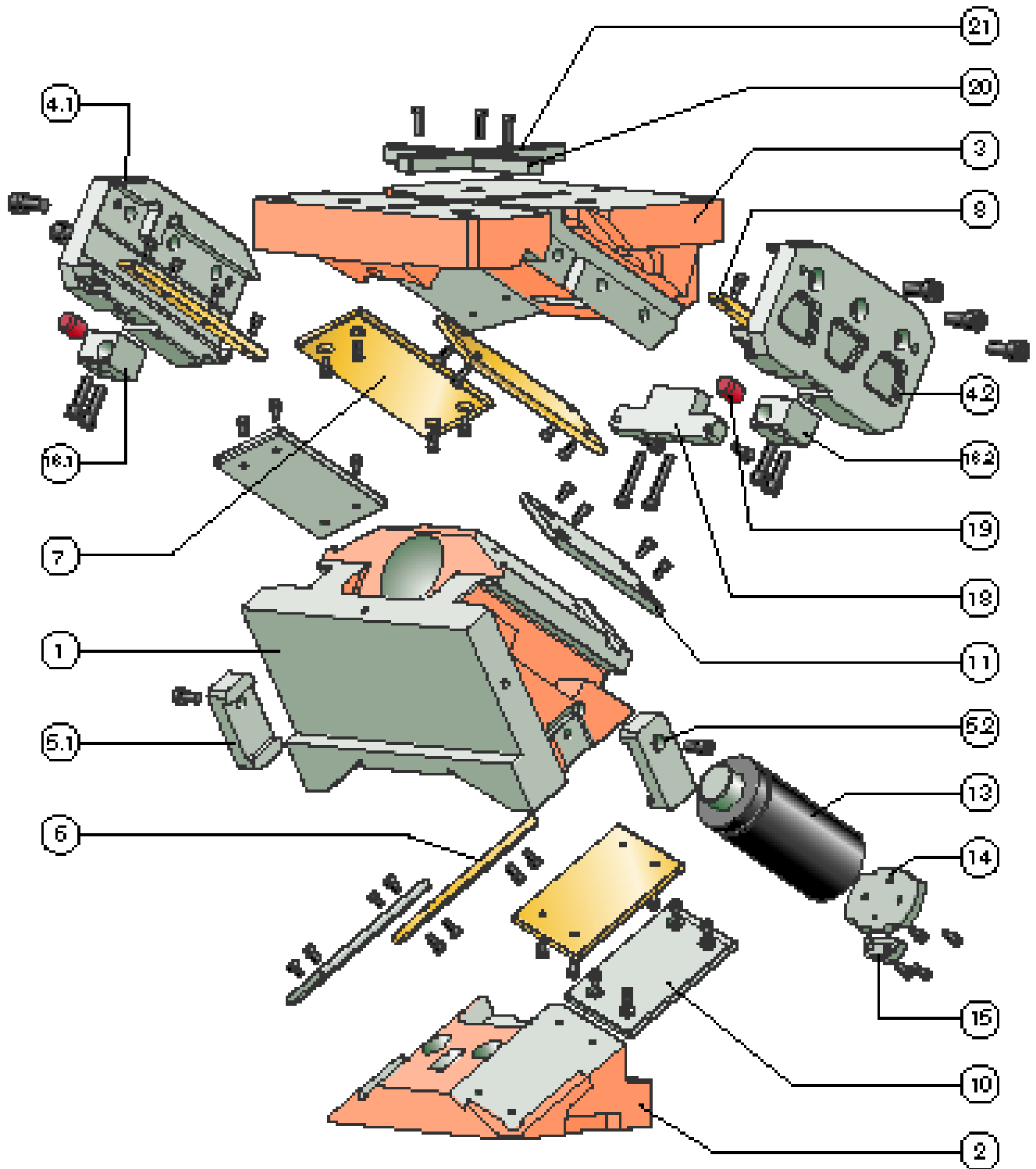

AERIAL FCC

2016.24.040.

PARTS LIST

Position	Piece	Designation	Material	spare part
1	1	Slider	GGG60	--
2	1	Cam driver	GGG60	--
2.1				
2.2				
3	1	Cam base	GGG60	--
4.1	1	Clamp, left	1.7225	x
4.2	1	Clamp, right	1.7225	x
5.1	1	Positive return, left	1.7225	x
5.2	1	Positive return, right	1.7225	x
6	2	Sliding plate	Bronze with solid lubricant	x
7	2	Sliding plate	Bronze with solid lubricant	x
8	2	Sliding plate	Bronze with solid lubricant	x
9				
10	2	Sliding plate	1.7131	x
11	2	Sliding plate	1.7131	x
12				
13	1	Gas spring	2487.12.03000.□□□	x
14	1	Stop plate	1.7225	x
15	1	Safety plate	1.1191	x
16.1	1	Cam slide stop, left	1.1191	x
16.2	1	Cam slide stop, right	1.1191	x
17				
18	1	Lockout system		x
19	2	Damping element	Elastomer	x
20	2	Feather key (T-nut)		x
21	1	Feather key (T-nut)		x
22				
23				
24				

For inquiries or when ordering spare parts (x), we require the following data:

- ▶ Cam unit order no.
- ▶ Cam unit serial no.
- ▶ Item number / Designation / Spare part

AERIAL FCC 2016.24.040. SYSTEM AND SURROUNDING FORCES

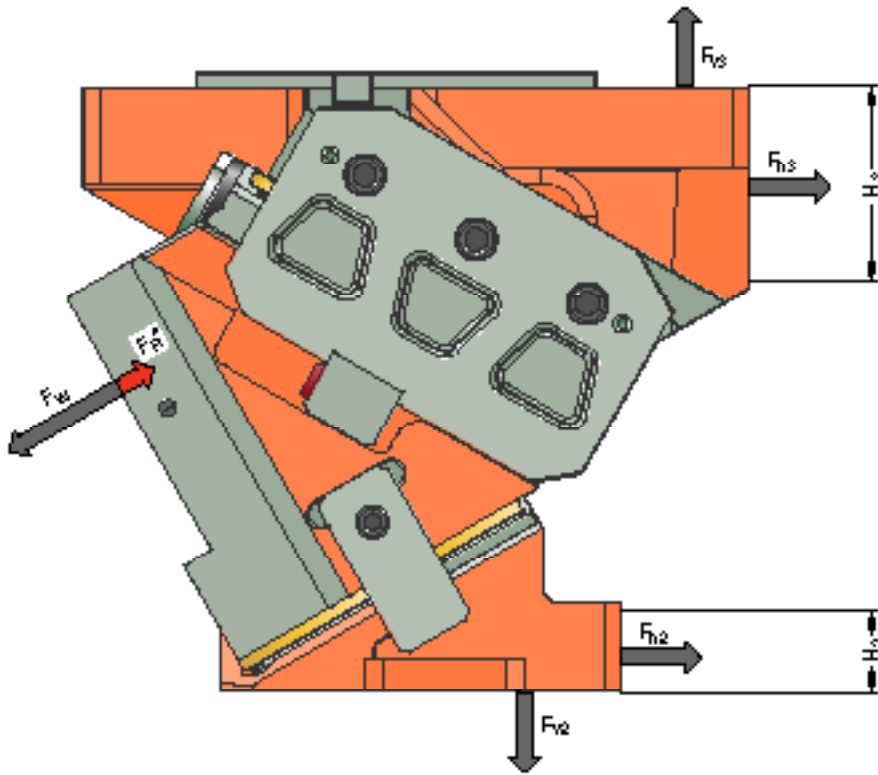

Order number	α [°]	F_W [kN]	F_R^* [kN]	F_{h2} [kN]	F_{v2} [kN]	F_{h3} [kN]	F_{v3} [kN]	H_2 [mm]	H_3 [mm]
2016.24.040.00.2000.00	0	1055	53.6	0	885	1055	885	30	176
2016.24.040.05.2000.00	5	1055	53.9	77	882	974	974	40	176
2016.24.040.10.2000.00	10	1054	59.3	128	727	910	910	40	176
2016.24.040.15.2000.00	15	1054	59.6	191	713	827	986	40	135
2016.24.040.20.2000.01	20	1054	59.8	252	694	738	1054	40	126
2016.24.040.25.2000.00	25	1054	67.2	257	552	698	997	40	134
2016.24.040.30.2000.00	30	1054	67.4	304	527	609	1054	40	125
2016.24.040.35.2000.00	35	1054	77.8	282	403	581	1007	40	125
2016.24.040.40.2000.00	40	1054	83.2	316	377	491	1054	50	110
2016.24.040.45.2000.00	45	1054	93.1	271	271	474	1017	50	140
2016.24.040.50.2000.00	50	1053	93.3	294	246	383	1053	60	120
2016.24.040.55.2000.00	55	1053	100.0	231	162	373	1024	70	120
2016.24.040.60.2000.00	60	1053	100.0	244	141	282	1053	80	112
2016.24.040.65.2000.00	65	1053	100.0	168	78	277	1033	32	100
2016.24.040.70.2000.00	70	1053	100.0	87	32	274	1021	32	100
2016.24.040.75.2000.00	75	1052	100.0	89	24	183	1040	32	49

* Retraction force values correspond to the spring-generated retraction force at the working point

The forces F_{h2} , F_{v2} as well as F_{h3} , F_{v3} act on the tool environment at maximum working force F_W .

AERIAL FCC

2016.24.040.

FORCE DIAGRAM

shouldered

		Width 400 mm							
		60	60	60	40	60	60	60	
Height 180 mm	0°	36	87	218	349	489	349	218	87
	36	36	120	301	446	676	446	301	120
	36	36	153	335	492	863	492	335	153
	36	36	185	355	520	1045	520	355	185
	36	36	186	349	512	1055	512	349	186

		Width 400 mm							
		60	60	60	40	60	60	60	
Height 180 mm	5°	36	84	206	327	475	327	206	84
	36	36	119	289	439	672	439	289	119
	36	36	154	341	500	868	500	341	154
	36	36	186	361	529	1046	529	361	186
	36	36	189	354	519	1055	519	354	189

		Width 400 mm							
		60	60	60	40	60	60	60	
Height 180 mm	10°	36	82	194	306	461	306	194	82
	36	36	119	278	432	667	432	278	119
	36	36	156	347	509	873	509	347	156
	36	36	187	367	537	1047	537	367	187
	36	36	192	359	525	1054	525	359	192

		Width 400 mm							
		60	60	60	40	60	60	60	
Height 180 mm	15°	36	80	182	284	448	284	182	80
	36	36	118	267	415	663	415	267	118
	36	36	157	351	517	878	517	351	157
	36	36	187	373	546	1049	546	373	187
	36	36	195	364	532	1054	532	364	195

		Width 400 mm							
		60	60	60	40	60	60	60	
Height 180 mm	20°	36	78	170	262	434	262	170	78
	36	36	118	255	392	658	392	255	118
	36	36	158	340	522	883	522	340	158
	36	36	188	379	555	1050	555	379	188
	36	36	198	368	539	1054	539	368	198

		Width 400 mm							
		60	60	60	40	60	60	60	
Height 180 mm	25°	36	75	158	241	420	241	158	75
	36	36	117	244	370	654	370	244	117
	36	36	159	329	499	888	499	329	159
	36	36	189	385	563	1051	563	385	189
	36	36	201	373	546	1054	546	373	201

Support with feather key

		Width 400 mm							
		60	60	60	40	60	60	60	
Height 180 mm	0°	36	72	109	141	171	141	109	72
	36	36	72	109	141	191	141	109	72
	36	36	72	109	141	191	141	109	72
	36	36	72	109	141	191	141	109	72
	36	36	72	109	141	191	141	109	72

		Width 400 mm							
		60	60	60	40	60	60	60	
Height 180 mm	5°	36	72	113	136	166	136	113	72
	36	36	72	113	136	182	136	113	72
	36	36	72	113	136	182	136	113	72
	36	36	72	113	136	182	136	113	72
	36	36	72	113	136	182	136	113	72

		Width 400 mm							
		60	60	60	40	60	60	60	
Height 180 mm	10°	36	72	97	138	162	138	97	72
	36	36	72	112	138	194	138	112	72
	36	36	72	112	138	194	138	112	72
	36	36	72	112	138	194	138	112	72
	36	36	72	112	138	194	138	112	72

		Width 400 mm							
		60	60	60	40	60	60	60	
Height 180 mm	15°	36	76	91	128	157	128	91	76
	36	36	76	117	153	219	153	117	76
	36	36	76	117	153	219	153	117	76
	36	36	76	117	153	219	153	117	76
	36	36	76	117	153	219	153	117	76

		Width 400 mm							
		60	60	60	40	60	60	60	
Height 180 mm	20°	36	75	85	118	152	118	85	75
	36	36	75	128	166	230	166	128	75
	36	36	75	128	166	240	166	128	75
	36	36	75	128	166	240	166	128	75
	36	36	75	128	166	240	166	128	75

		Width 400 mm							
		60	60	60	40	60	60	60	
Height 180 mm	25°	36	73	79	108	147	108	79	73
	36	36	73	122	167	229	167	122	73
	36	36	73	130	175	259	175	130	73
	36	36	73	130	175	259	175	130	73
	36	36	73	130	175	259	175	130	73

AERIAL FCC

2016.24.040.

FORCE DIAGRAM

shouldered

		Width 400 mm							
		60	60	60	40	60	60	60	
30°	Height 180 mm	36	73	146	219	406	219	146	73
		36	117	232	348	650	348	232	117
		36	161	318	476	893	476	318	161
		36	189	376	562	1053	562	376	189
		36	203	378	553	1054	553	378	203

Support with feather key

		Width 400 mm							
		60	60	60	40	60	60	60	
30°	Height 180 mm	36	71	73	99	142	99	73	71
		36	80	116	159	227	159	116	80
		36	80	132	187	297	187	132	80
		36	80	132	187	297	187	132	80
		36	80	132	187	297	187	132	80

35°

		Width 400 mm							
		60	60	60	40	60	60	60	
35°	Height 180 mm	36	71	134	198	392	198	134	71
		36	116	221	325	645	325	221	116
		36	162	307	453	898	453	307	162
		36	190	361	531	1054	531	361	190
		36	206	383	559	1054	559	383	206

35°

		Width 400 mm							
		60	60	60	40	60	60	60	
35°	Height 180 mm	36	69	74	99	157	99	74	69
		36	81	121	163	258	163	121	81
		36	81	134	189	310	189	134	81
		36	81	134	189	310	189	134	81
		36	81	134	189	310	189	134	81

40°

		Width 400 mm							
		60	60	60	40	60	60	60	
40°	Height 180 mm	36	77	143	209	393	209	143	77
		36	125	233	340	641	340	233	125
		36	173	322	472	889	472	322	173
		36	206	384	561	1054	561	384	206
		36	219	391	563	1054	563	391	219

40°

		Width 400 mm							
		60	60	60	40	60	60	60	
40°	Height 180 mm	36	75	79	105	157	105	79	75
		36	92	128	170	256	170	128	92
		36	92	162	205	356	205	162	92
		36	92	162	205	358	205	162	92
		36	92	162	205	358	205	162	92

45°

		Width 400 mm							
		60	60	60	40	60	60	60	
45°	Height 180 mm	36	83	152	221	394	221	152	83
		36	134	245	356	637	356	245	134
		36	184	337	490	880	490	337	184
		36	222	406	582	1054	582	406	222
		36	232	399	567	1053	567	399	232

45°

		Width 400 mm							
		60	60	60	40	60	60	60	
45°	Height 180 mm	36	83	91	122	177	122	91	83
		36	108	147	196	287	196	147	108
		36	108	202	227	382	227	202	108
		36	108	202	227	382	227	202	108
		36	108	202	227	382	227	202	108

50°

		Width 400 mm							
		60	60	60	40	60	60	60	
50°	Height 180 mm	36	90	161	233	395	233	161	90
		36	142	257	371	633	371	257	142
		36	195	352	509	871	509	352	195
		36	239	416	584	1053	584	416	239
		36	245	408	571	1053	571	408	245

50°

		Width 400 mm							
		60	60	60	40	60	60	60	
50°	Height 180 mm	36	90	97	128	178	128	97	90
		36	108	154	204	285	204	154	108
		36	108	189	274	392	274	189	108
		36	108	189	274	474	274	189	108
		36	108	189	274	474	274	189	108

55°

		Width 400 mm							
		60	60	60	40	60	60	60	
55°	Height 180 mm	36	96	170	244	396	244	170	96
		36	151	269	386	629	386	269	151
		36	206	367	528	862	528	367	206
		36	255	423	585	1053	585	423	255
		36	257	416	575	1053	575	416	257

55°

		Width 400 mm							
		60	60	60	40	60	60	60	
55°	Height 180 mm	36	96	107	134	198	134	107	96
		36	123	169	212	314	212	169	123
		36	123	202	290	431	290	202	123
		36	123	204	290	495	290	204	123
		36	123	202	290	495	290	202	123

AERIAL FCC

2016.24.040.

FORCE DIAGRAM

shouldered

		Width 400 mm							
		60	60	60	40	60	60	60	
Height 180 mm	60°	36	102	179	256	396	256	179	102
	36	36	160	281	401	625	401	281	160
	36	36	218	382	547	853	547	382	218
	36	36	271	429	586	1053	586	429	271
	36	36	270	424	578	1053	578	424	270
	36	36							

Support with feather key

		Width 400 mm							
		60	60	60	40	60	60	60	
Height 180 mm	60°	36	102	113	141	198	141	113	102
	36	36	147	177	221	312	221	177	147
	36	36	147	241	301	427	301	241	147
	36	36	147	270	322	526	322	270	147
	36	36	147	267	318	526	318	267	147
	36	36							

65°

		Width 400 mm							
		60	60	60	40	60	60	60	
Height 180 mm	65°	36	108	188	268	397	268	188	108
	36	36	169	293	417	621	417	293	169
	36	36	229	397	566	845	566	397	229
	36	36	285	436	587	1053	587	436	285
	36	36	283	433	582	1053	582	433	283
	36	36							

65°

		Width 400 mm							
		60	60	60	40	60	60	60	
Height 180 mm	65°	36	108	118	161	218	161	118	108
	36	36	196	184	250	341	250	184	196
	36	36	196	250	339	465	339	250	196
	36	36	196	275	352	579	352	275	196
	36	36	196	273	349	579	349	273	196
	36	36							

70°

		Width 400 mm							
		60	60	60	40	60	60	60	
Height 180 mm	70°	36	115	197	279	398	279	197	115
	36	36	177	305	432	617	432	305	177
	36	36	240	412	585	836	585	412	240
	36	36	296	442	588	1052	588	442	296
	36	36	296	441	586	1053	586	441	296
	36	36							

70°

		Width 400 mm							
		60	60	60	40	60	60	60	
Height 180 mm	70°	36	115	152	265	280	265	152	115
	36	36	177	235	410	487	410	235	177
	36	36	190	317	410	666	410	317	190
	36	36	190	317	410	666	410	317	190
	36	36	190	317	450	664	450	317	190
	36	36							

75°

		Width 400 mm							
		60	60	60	40	60	60	60	
Height 180 mm	75°	36	121	206	291	399	291	206	121
	36	36	186	317	447	613	447	317	186
	36	36	251	427	603	827	603	427	251
	36	36	308	449	589	1051	589	449	308
	36	36	309	449	590	1052	590	449	309
	36	36							

75°

		Width 400 mm							
		60	60	60	40	60	60	60	
Height 180 mm	75°	36	121	159	276	347	276	159	121
	36	36	186	244	425	533	425	244	186
	36	36	251	329	573	719	573	329	251
	36	36	308	345	559	914	559	345	308
	36	36	309	346	560	916	560	346	309
	36	36							



AERIAL FCC 2016.24.050.

Working width: 500 mm
Performance class: 1150 kN

AERIAL FCC
2016.24.050.
 SIZE TABLE

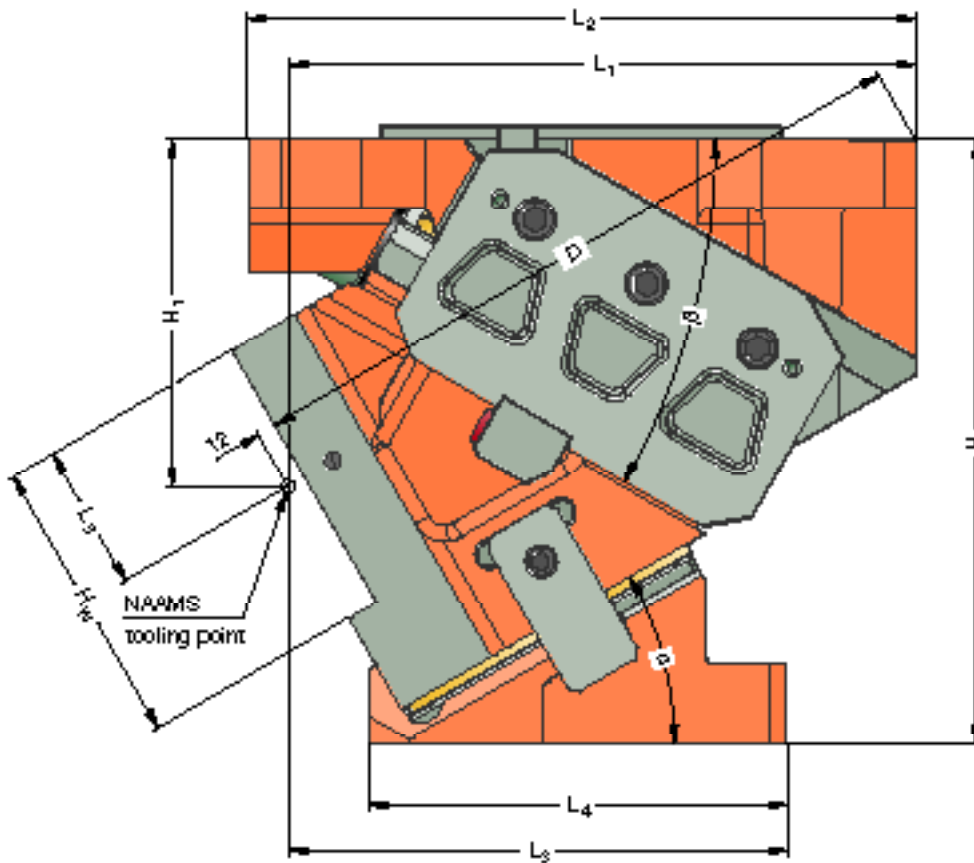
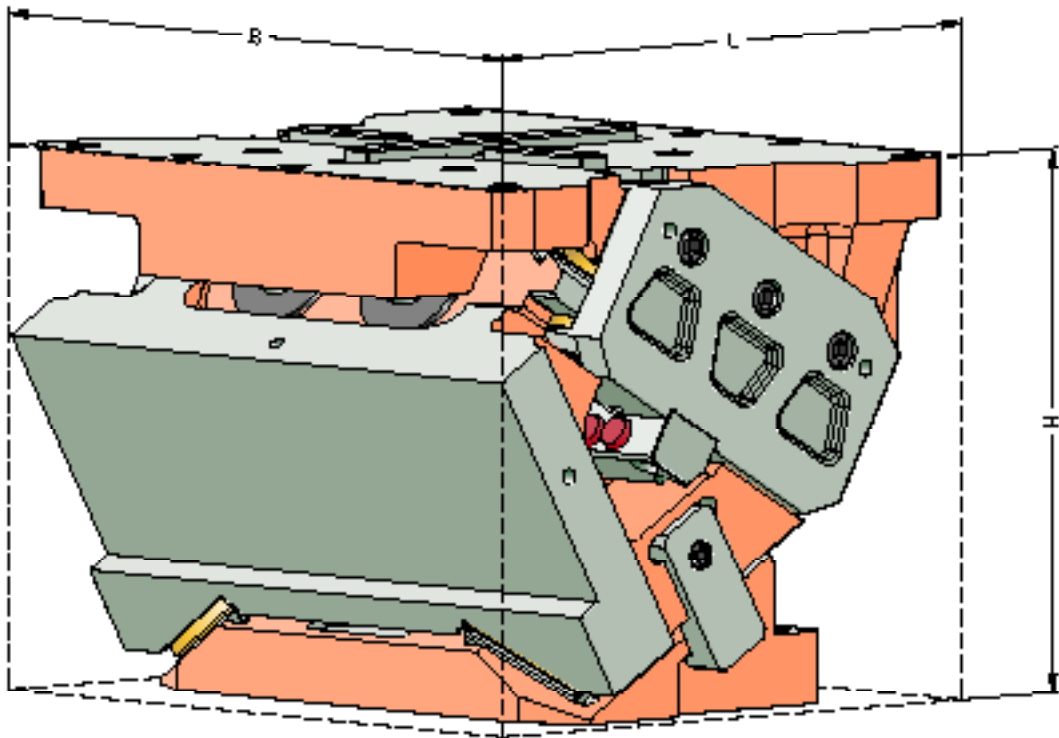

AERIAL FCC

2016.24.050.

SIZE TABLE

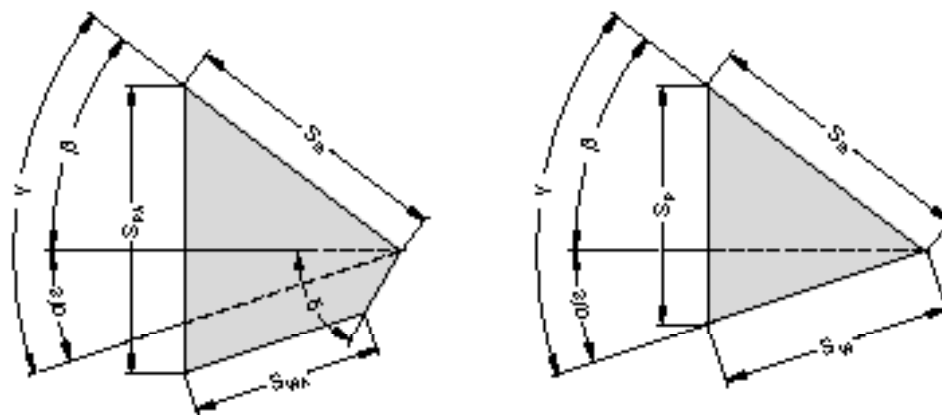

Order number	L	B	H	H ₁	H _W	L ₁	L ₂	L ₃	L ₄	L ₅	D	α	β	δ	S _W *	S _{WA} *	S _S	S _P *	S _{PA} *
2016.24.050.	[mm]	[mm]	[mm]	[mm]	[mm]	[mm]	[mm]	[mm]	[mm]	[mm]	[mm]	[°]	[°]	[°]	[mm]	[mm]	[mm]	[mm]	[mm]
00.2000.00	423	500	375	180	180	415	415	285	280	105	403.0	0	50	30	-	28.6	58	-	49.4
05.2000.00	415	500	375	185	180	415	415	285	280	90	417.5	5	45	35	-	32.9	58	-	49.6
10.2000.00	419	500	375	190	180	415	415	285	267	90	429.7	10	45	40	-	33.9	58	-	53.3
15.2000.00	435	500	375	200	180	415	415	285	258	90	446.4	15	40	45	-	38.7	58	-	54.4
20.2000.00	439	500	375	195	180	415	415	285	267	90	439.3	20	35	50	-	43.7	58	-	55.9
25.2000.00	417	500	375	205	180	390	415	310	270	90	428.1	25	35	55	-	46.1	58	-	60.9
30.2000.00	417	500	375	215	180	390	415	310	260	90	432.3	30	30	60	-	52.2	58	-	63.8
35.2000.00	428	500	375	225	180	390	415	310	247	83	436.5	35	30	65	-	56.2	58	-	70.3
40.2000.00	439	500	375	235	180	390	415	310	240	90	437.8	40	25	70	-	64.2	58	-	75.1
45.2000.00	455	500	375	245	180	340	455	310	225	90	401.7	45	25	75	-	70.7	58	-	84.1
50.2000.00	450	500	375	265	180	340	450	310	223	105	409.6	50	20	-	84.8	-	58	84.8	-
55.2000.00	450	500	375	285	180	340	450	310	232	110	416.5	55	20	-	95.0	-	58	97.7	-
60.2000.00	450	500	375	300	180	340	450	310	229	115	417.8	60	15	-	112.0	-	58	112.0	-
65.2000.00	450	500	375	300	180	340	450	340	250	110	403.6	65	15	-	102.9	-	45	104.9	-
70.2000.00	450	500	375	300	180	340	450	340	228	100	386.2	70	15	-	127.1	-	45	131.1	-
75.2000.00	450	500	375	300	180	325	450	325	213	100	361.9	75	10	-	114.2	-	30	115.5	-

* Values rounded

Fastening cam base:

Hexagon socket head cap screws DIN EN ISO 4762
Dowel pins DIN EN ISO 8735

6x M20 / Strength class min. 8.8
2x Ø20

Fastening cam driver :

Hexagon socket head cap screws DIN EN ISO 4762
Dowel pins DIN EN ISO 8735

4x M20 / Strength class min. 8.8
4x Ø20

AERIAL FCC
2016.24.050.
 EXPLODED VIEW

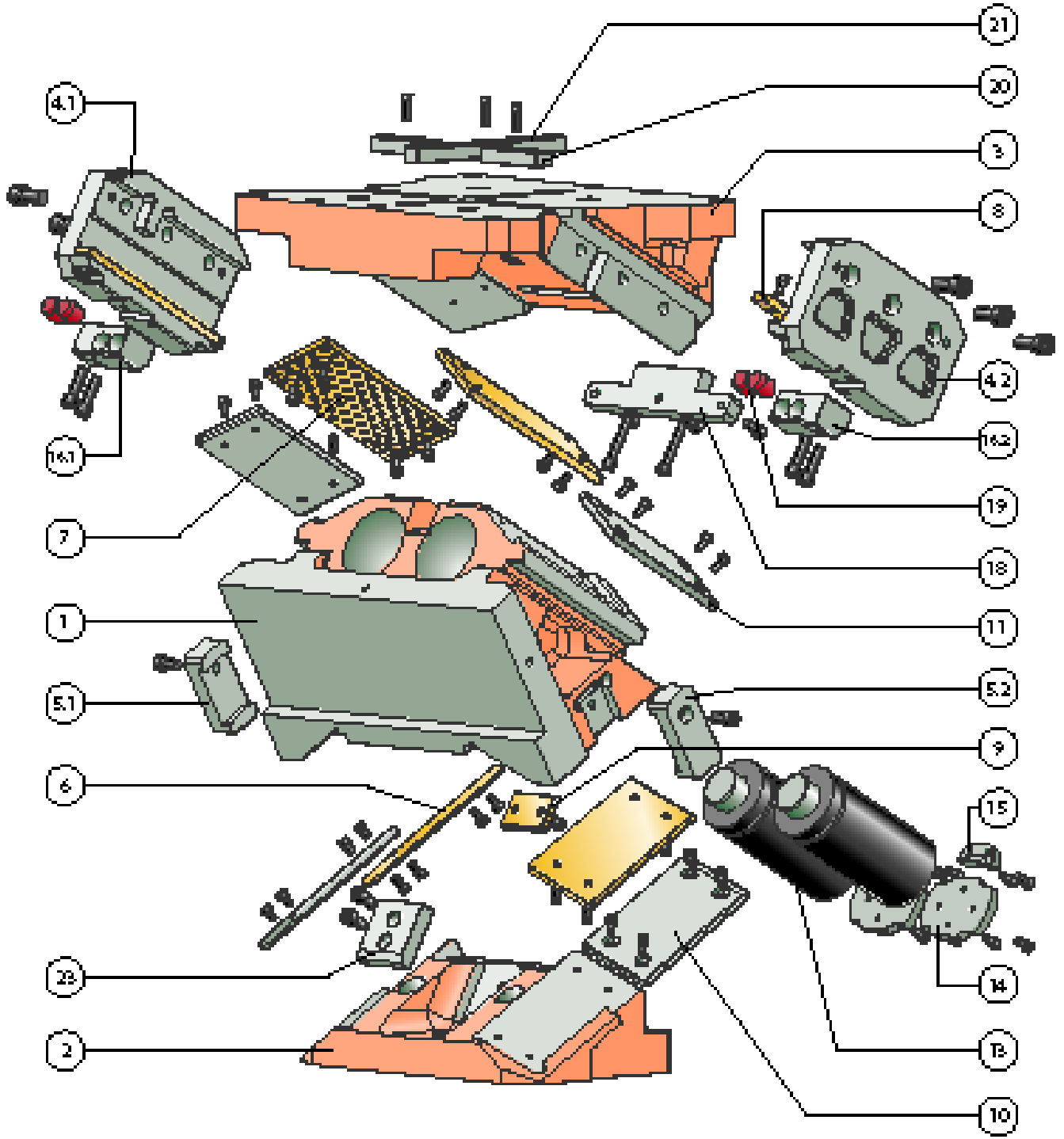

AERIAL FCC

2016.24.050.

PARTS LIST

Position	Piece	Designation	Material	spare part
1	1	Slider	GGG60	--
2	1	Cam driver	GGG60	--
2.1				
2.2				
3	1	Cam base	GGG60	--
4.1	1	Clamp, left	1.7225	x
4.2	1	Clamp, right	1.7225	x
5.1	1	Positive return, left	1.7225	x
5.2	1	Positive return, right	1.7225	x
6	2	Sliding plate	Bronze with solid lubricant	x
7	2	Sliding plate	Bronze with solid lubricant	x
8	2	Sliding plate	Bronze with solid lubricant	x
9*	2	Sliding plate	Bronze with solid lubricant	x
10	2	Sliding plate	1.7131	x
11	2	Sliding plate	1.7131	x
12				
13	2	Gas spring	2487.12.03000.□□□	x
14	2	Stop plate	1.7225	x
15	2	Safety plate	1.1191	x
16.1	1	Cam slide stop, left	1.1191	x
16.2	1	Cam slide stop, right	1.1191	x
17				
18	1	Lockout system		x
19	4	Damping element	Elastomer	x
20	2	Feather key (T-nut)		x
21	1	Feather key (T-nut)		x
22				
23*	1	Pre-acceleration		x
24				

* up to and including 45° with pre-acceleration

For inquiries or when ordering spare parts (x), we require the following data:

- ▶ Cam unit order no.
- ▶ Cam unit serial no.
- ▶ Item number / Designation / Spare part

AERIAL FCC 2016.24.050. SYSTEM AND SURROUNDING FORCES

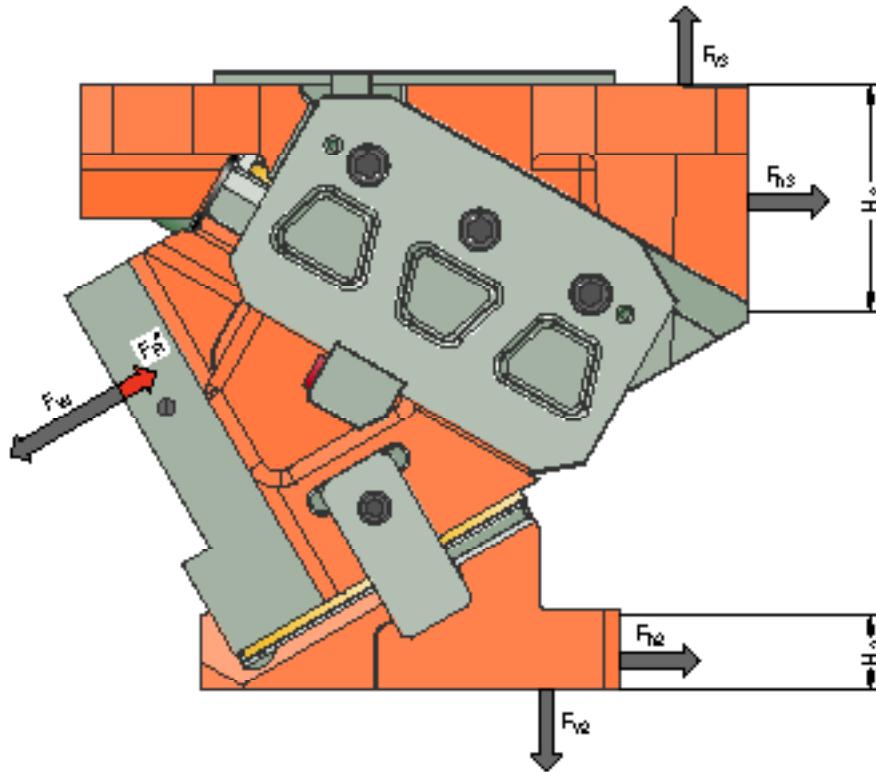

Order number	α [°]	F_W [kN]	F_R^* [kN]	F_{h2} [kN]	F_{v2} [kN]	F_{h3} [kN]	F_{v3} [kN]	H_2 [mm]	H_3 [mm]
2016.24.050.00.2000.00	0	1155	108.4	0	969	1155	969	30	179
2016.24.050.05.2000.00	5	1155	109.0	84	965	1066	1066	40	172
2016.24.050.10.2000.00	10	1155	120.3	140	796	997	997	40	174
2016.24.050.15.2000.00	15	1155	120.9	209	781	906	1080	40	137
2016.24.050.20.2000.00	20	1155	121.4	277	760	809	1155	40	155
2016.24.050.25.2000.00	25	1155	125.0	282	604	765	1092	40	170
2016.24.050.30.2000.00	30	1155	125.0	333	578	667	1155	40	146
2016.24.050.35.2000.00	35	1155	125.0	309	441	637	1104	40	143
2016.24.050.40.2000.00	40	1155	125.0	346	413	539	1155	60	115
2016.24.050.45.2000.00	45	1155	125.0	297	297	519	1114	70	140
2016.24.050.50.2000.00	50	1155	125.0	322	270	420	1155	80	117
2016.24.050.55.2000.00	55	1155	125.0	254	178	409	1124	80	109
2016.24.050.60.2000.00	60	1155	125.0	268	155	309	1155	90	103
2016.24.050.65.2000.00	65	1155	125.0	185	86	304	1133	89	83
2016.24.050.70.2000.00	70	1155	125.0	95	35	300	1120	116	100
2016.24.050.75.2000.00	75	1155	125.0	98	26	201	1142	146	77

* Retraction force values correspond to the spring-generated retraction force at the working point

The forces F_{h2} , F_{v2} as well as F_{h3} , F_{v3} act on the tool environment at maximum working force F_W .

AERIAL FCC

2016.24.050.

FORCE DIAGRAM

shouldered

		Width 500 mm									
		50	50	60	60	60	60	60	50	50	
Height 180 mm	0°	36	140	190	227	272	316	272	227	190	140
	36	36	143	264	375	507	640	507	375	264	143
	36	36	145	317	472	659	846	659	472	317	145
	36	36	148	357	546	773	1000	773	546	357	148
	36	36	151	397	620	887	1006	887	620	397	151
	36	36									

		Width 500 mm									
		50	50	60	60	60	60	60	50	50	
Height 180 mm	5°	36	138	210	268	333	398	333	268	210	138
	36	36	146	268	378	511	643	511	378	268	146
	36	36	154	325	480	667	853	667	480	325	154
	36	36	159	366	553	779	1004	779	553	366	159
	36	36	164	406	626	891	1155	891	626	406	164
	36	36									

		Width 500 mm									
		50	50	60	60	60	60	60	50	50	
Height 180 mm	10°	36	137	209	274	353	431	353	274	209	137
	36	36	150	271	381	541	646	541	381	271	150
	36	36	163	334	489	675	861	675	489	334	163
	36	36	170	375	561	784	1008	784	561	375	170
	36	36	176	416	633	894	1155	894	633	416	176
	36	36									

		Width 500 mm									
		50	50	60	60	60	60	60	50	50	
Height 180 mm	15°	36	135	207	272	351	430	351	272	207	135
	36	36	153	275	385	517	649	517	385	275	153
	36	36	172	342	497	683	868	683	497	342	172
	36	36	180	384	568	790	1012	790	568	384	180
	36	36	189	425	640	897	1155	897	640	425	189
	36	36									

		Width 500 mm									
		50	50	60	60	60	60	60	50	50	
Height 180 mm	20°	36	143	214	280	358	436	358	280	214	143
	36	36	157	278	389	521	653	521	389	278	157
	36	36	172	342	498	684	870	684	498	342	172
	36	36	170	376	563	788	1012	788	563	376	170
	36	36	168	409	629	892	1155	892	629	409	168
	36	36									

		Width 500 mm									
		50	50	60	60	60	60	60	50	50	
Height 180 mm	25°	36	150	222	287	365	443	365	287	222	150
	36	36	161	282	393	525	657	525	393	282	161
	36	36	172	343	498	685	872	685	498	343	172
	36	36	159	368	558	786	1013	786	558	368	159
	36	36	147	393	617	886	1155	886	617	393	147
	36	36									

Support with feather key

		Width 500 mm									
		50	50	60	60	60	60	60	50	50	
Height 180 mm	0°	36	63	82	109	160	210	160	109	82	63
	36	36	64	82	110	161	212	161	110	82	64
	36	36	64	82	110	163	214	163	110	82	64
	36	36	66	82	110	173	237	173	110	82	66
	36	36	68	82	110	173	237	173	110	82	68
	36	36									

		Width 500 mm									
		50	50	60	60	60	60	60	50	50	
Height 180 mm	5°	36	64	88	116	173	230	173	116	88	64
	36	36	65	88	116	175	233	175	116	88	65
	36	36	66	88	116	177	235	177	116	88	66
	36	36	68	88	116	180	245	180	116	88	68
	36	36	69	88	116	180	245	180	116	88	69
	36	36									

		Width 500 mm									
		50	50	60	60	60	60	60	50	50	
Height 180 mm	10°	36	64	88	112	186	250	186	112	88	64
	36	36	66	88	112	189	253	189	112	88	66
	36	36	68	88	112	192	256	192	112	88	68
	36	36	69	88	112	198	265	198	112	88	69
	36	36	71	88	112	204	274	204	112	88	71
	36	36									

		Width 500 mm									
		50	50	60	60	60	60	60	50	50	
Height 180 mm	15°	36	65	89	117	200	270	200	117	89	65
	36	36	68	89	117	203	273	203	117	89	68
	36	36	70	89	117	206	277	206	117	89	70
	36	36	71	89	117	208	279	208	117	89	71
	36	36	73	89	117	210	281	210	117	89	73
	36	36									

		Width 500 mm									
		50	50	60	60	60	60	60	50	50	
Height 180 mm	20°	36	72	93	128	189	250	189	128	93	72
	36	36	74	93	130	192	253	192	130	93	74
	36	36	76	93	133	194	256	194	133	93	76
	36	36	77	93	135	197	260	197	135	93	77
	36	36	79	93	137	201	264	201	137	93	79
	36	36									

		Width 500 mm									
		50	50	60	60	60	60	60	50	50	
Height 180 mm	25°	36	79	97	126	178	230	178	126	97	79
	36	36	80	97	128	180	233	180	128	97	80
	36	36	82	97	130	183	235	183	130	97	82
	36	36	83	97	133	187	241	187	133	97	83
	36	36	85	97	136	192	248	192	136	97	85
	36	36									

AERIAL FCC

2016.24.050.

FORCE DIAGRAM

shouldered

		Width 500 mm								
30°		50	50	60	60	60	60	60	50	50
Height 180 mm	36	151	229	294	372	450	372	294	229	151
	36	165	286	397	529	662	529	397	286	165
	36	172	343	499	686	873	686	499	343	172
	36	149	360	553	783	1014	783	553	360	149
	36	126	378	606	881	1155	881	606	378	126

		Width 500 mm								
35°		50	50	60	60	60	60	60	50	50
Height 180 mm	36	144	219	287	369	450	369	287	219	144
	36	161	284	396	530	665	530	396	284	161
	36	178	349	505	692	880	692	505	349	178
	36	166	374	563	790	1017	790	563	374	166
	36	154	399	621	888	1155	888	621	399	154

		Width 500 mm								
40°		50	50	60	60	60	60	60	50	50
Height 180 mm	36	131	209	280	365	450	365	280	209	131
	36	157	282	396	532	668	532	396	282	157
	36	183	355	511	699	886	699	511	355	183
	36	183	387	574	797	1021	797	574	387	183
	36	182	420	636	896	1155	896	636	420	182

		Width 500 mm								
45°		50	50	60	60	60	60	60	50	50
Height 180 mm	36	118	199	273	362	442	362	273	199	118
	36	154	280	395	533	671	533	395	280	154
	36	186	361	517	705	893	705	517	361	186
	36	200	401	584	804	1024	804	584	401	200
	36	210	441	651	903	1155	903	651	441	210

		Width 500 mm								
50°		50	50	60	60	60	60	60	50	50
Height 180 mm	36	122	201	272	349	420	349	272	201	122
	36	148	279	399	542	685	542	399	279	148
	36	174	358	525	726	927	726	525	358	174
	36	183	393	584	812	1041	812	584	393	183
	36	193	428	642	898	1155	898	642	428	193

		Width 500 mm								
55°		50	50	60	60	60	60	60	50	50
Height 180 mm	36	126	202	259	328	397	328	259	202	126
	36	143	279	402	550	699	550	402	279	143
	36	160	356	534	747	961	747	534	356	160
	36	167	385	583	820	1058	820	583	385	167
	36	175	415	632	894	1155	894	632	415	175

Support with feather key

		Width 500 mm								
30°		50	50	60	60	60	60	60	50	50
Height 180 mm	36	86	105	125	167	210	167	125	105	86
	36	86	105	126	169	212	169	126	105	86
	36	86	105	128	171	214	171	128	105	86
	36	86	105	161	177	223	177	161	105	86
	36	86	105	135	183	231	183	135	105	86

		Width 500 mm								
35°		50	50	60	60	60	60	60	50	50
Height 180 mm	36	82	93	111	180	266	180	111	93	82
	36	85	101	127	220	288	220	127	101	85
	36	86	101	133	235	310	235	133	101	86
	36	86	101	135	241	318	241	135	101	86
	36	86	101	135	248	325	248	135	101	86

		Width 500 mm								
40°		50	50	60	60	60	60	60	50	50
Height 180 mm	36	90	92	113	175	322	175	113	92	90
	36	92	101	125	221	364	221	125	101	92
	36	94	110	145	237	406	237	145	110	94
	36	94	110	145	280	413	280	145	110	94
	36	94	110	145	280	419	280	145	110	94

		Width 500 mm								
45°		50	50	60	60	60	60	60	50	50
Height 180 mm	36	92	127	182	222	378	222	182	127	92
	36	95	129	203	283	440	283	203	129	95
	36	100	131	224	313	502	313	224	131	100
	36	100	131	224	313	508	313	224	131	100
	36	100	131	224	313	513	313	224	131	100

		Width 500 mm								
50°		50	50	60	60	60	60	60	50	50
Height 180 mm	36	93	105	129	187	363	187	129	105	93
	36	103	125	153	207	486	207	153	125	103
	36	105	137	169	296	609	296	169	137	105
	36	107	140	173	325	617	325	173	140	107
	36	107	140	173	325	625	325	173	140	107

		Width 500 mm								
55°		50	50	60	60	60	60	60	50	50
Height 180 mm	36	105	113	132	187	347	187	132	113	105
	36	107	132	160	263	531	263	160	132	107
	36	122	150	185	315	630	315	185	150	122
	36	127	156	185	339	659	339	185	156	127
	36	132	156	185	339	659	339	185	156	132

AERIAL FCC 2016.24.050. FORCE DIAGRAM

shouldered

		Width 500 mm										
		50	50	60	60	60	60	60	50	50		
Height 180 mm	36	124	185	241	308	375	308	241	185	124		
	36	138	278	406	559	712	559	406	278	138		
	36	145	353	542	768	995	768	542	353	145		
	36	151	377	582	829	1075	829	582	377	151		
	36	158	401	623	889	1155	889	623	401	158		

Support with feather key

		Width 500 mm										
		50	50	60	60	60	60	60	50	50		
Height 180 mm	36	105	111	131	170	332	170	131	111	105		
	36	109	126	150	225	483	225	150	126	109		
	36	120	157	208	298	822	298	208	157	120		
	36	138	180	227	420	835	420	227	180	138		
	36	140	180	227	420	849	420	227	180	140		

65°

		Width 500 mm										
		50	50	60	60	60	60	60	50	50		
Height 180 mm	36	128	186	238	301	363	301	238	186	128		
	36	147	290	413	560	707	560	413	290	147		
	36	167	363	542	756	970	756	542	363	167		
	36	181	397	592	828	1063	828	592	397	181		
	36	195	430	643	899	1155	899	643	430	195		

65°

		Width 500 mm										
		50	50	60	60	60	60	60	50	50		
Height 180 mm	36	123	126	151	169	260	169	151	126	123		
	36	127	147	173	228	502	228	173	147	127		
	36	153	193	221	279	750	279	221	193	153		
	36	165	201	268	449	880	449	268	201	165		
	36	177	207	268	473	880	473	268	207	177		

70°

		Width 500 mm										
		50	50	60	60	60	60	60	50	50		
Height 180 mm	36	132	186	235	293	352	293	235	186	132		
	36	146	271	385	521	658	521	385	271	146		
	36	161	357	536	744	946	744	536	357	161		
	36	209	416	603	827	1051	827	603	416	209		
	36	233	458	663	909	1155	909	663	458	233		

70°

		Width 500 mm										
		50	50	60	60	60	60	60	50	50		
Height 180 mm	36	125	150	181	227	240	227	181	150	125		
	36	143	175	207	263	500	263	207	175	143		
	36	160	223	245	325	753	325	245	223	160		
	36	193	245	360	521	890	521	360	245	193		
	36	215	245	390	553	890	553	390	245	215		

75°

		Width 500 mm										
		50	50	60	60	60	60	60	50	50		
Height 180 mm	36	136	186	231	286	340	286	231	186	136		
	36	145	253	351	468	585	468	351	253	145		
	36	155	320	470	651	831	651	470	320	155		
	36	202	400	579	794	1009	794	579	400	202		
	36	250	479	683	919	1155	919	683	479	250		

75°

		Width 500 mm										
		50	50	60	60	60	60	60	50	50		
Height 180 mm	36	126	157	220	230	290	230	220	157	126		
	36	141	175	220	260	557	260	220	175	141		
	36	155	278	419	551	831	551	419	278	155		
	36	202	303	478	691	1038	691	478	303	202		
	36	250	325	536	702	1155	702	536	325	250		

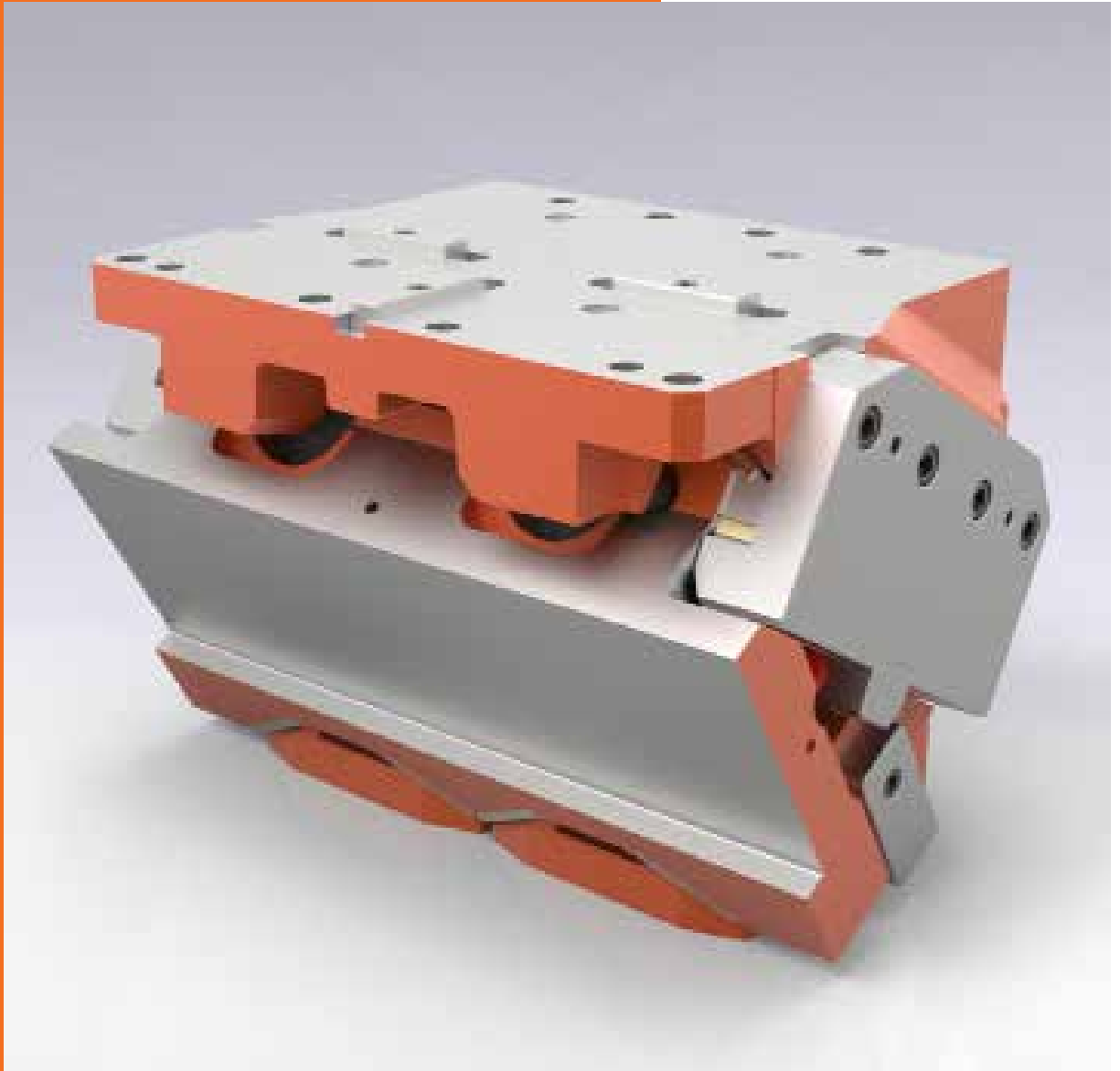

AERIAL FCC 2016.24.060.

Working width: 600 mm
Performance class: 1200 kN

AERIAL FCC
2016.24.060.
 SIZE TABLE

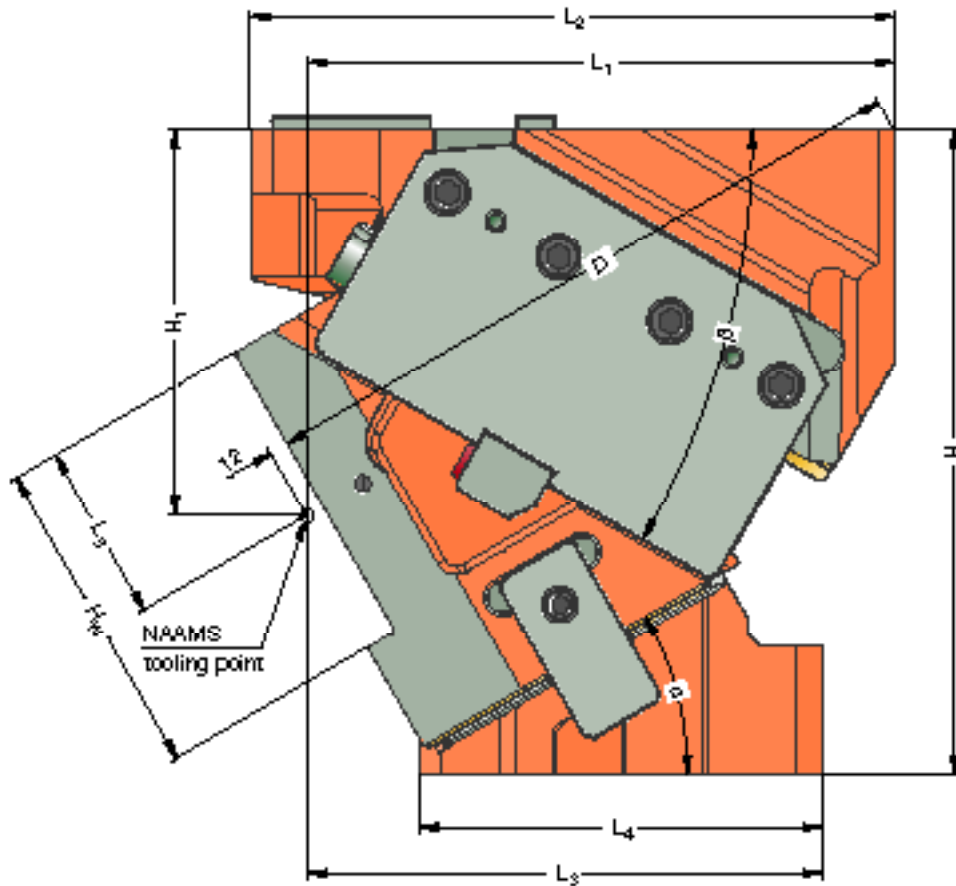
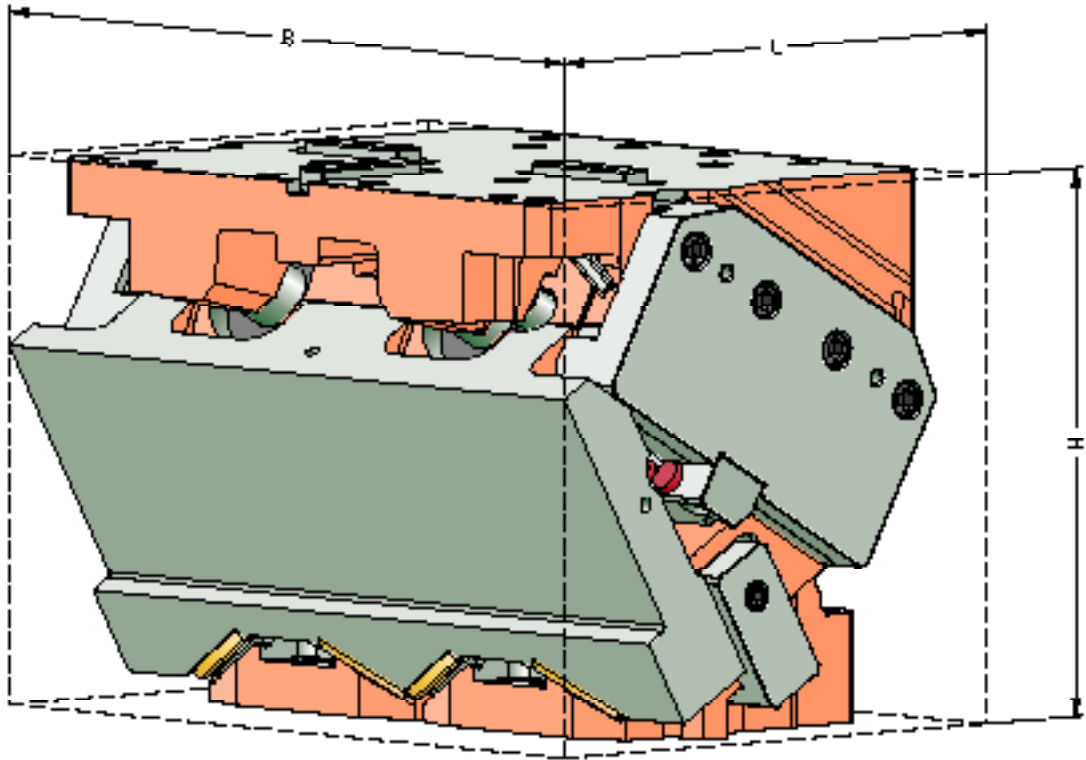

AERIAL FCC

2016.24.060.

SIZE TABLE

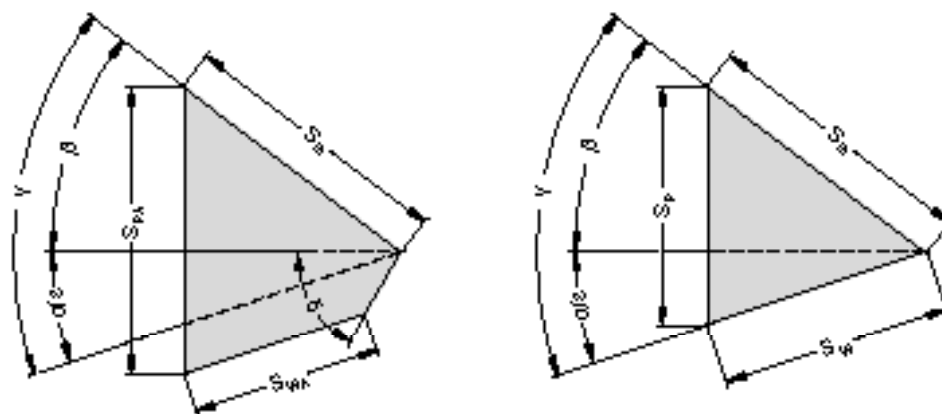

Order number	L	B	H	H ₁	H _W	L ₁	L ₂	L ₃	L ₄	L ₅	D	α	β	δ	S _W *	S _{VA} *	S _S	S _P *	S _{PA} *
2016.24.060.	[mm]	[mm]	[mm]	[mm]	[mm]	[mm]	[mm]	[mm]	[mm]	[mm]	[mm]	[°]	[°]	[°]	[mm]	[mm]	[mm]	[mm]	[mm]
00.2000.00	388	600	400	185	200	380	385	260	255	110	368.0	0	50	45	-	25.0	58	-	56.7
05.2000.00	385	600	400	200	200	380	385	275	258	110	384.0	5	45	50	-	25.0	58	-	62.3
10.2000.00	387	600	400	210	200	380	385	275	245	110	398.7	10	45	45	-	25.0	58	-	61.8
15.2000.00	397	600	400	220	200	380	385	285	245	110	412.0	15	40	50	-	35.0	58	-	59.0
20.2000.00	391	600	400	230	200	365	380	310	260	110	409.7	20	35	45	-	35.0	58	-	59.9
25.2000.00	401	600	400	240	200	365	380	310	250	110	420.2	25	35	50	-	35.0	58	-	66.8
30.2000.00	410	600	400	240	200	365	400	320	250	110	424.1	30	30	45	-	35.0	58	-	66.4
35.2000.00	418	600	400	250	200	365	415	360	280	110	430.4	35	30	50	-	40.0	58	-	72.8
40.2000.00	435	600	400	260	200	365	435	360	275	110	434.7	40	25	55	-	50.0	58	-	77.0
45.2000.00	435	600	400	270	200	365	435	360	265	110	437.0	45	25	60	-	55.0	58	-	87.1
50.2000.00	460	600	400	280	200	320	455	325	225	140	408.1	50	20	-	84.8	-	58	84.8	-
55.2000.00	460	600	400	290	200	320	455	325	215	140	409.1	55	20	-	95.0	-	58	97.7	-
60.2000.00	470	600	400	305	200	310	455	325	215	140	407.1	60	15	-	112.0	-	58	112.0	-
65.2000.00	495	600	400	315	200	310	495	305	185	140	404.5	65	15	-	102.9	-	45	104.9	-
70.2000.00	495	600	400	330	200	310	495	305	180	140	404.1	70	15	-	127.1	-	45	131.1	-
75.2000.00	495	600	400	340	200	310	495	305	175	140	396.6	75	10	-	114.2	-	30	115.5	-

* Values rounded

Fastening cam base:

Hexagon socket head cap screws DIN EN ISO 4762
Dowel pins DIN EN ISO 8735

8x M20 / Strength class min. 8.8
2x Ø20

Fastening cam driver :

Hexagon socket head cap screws DIN EN ISO 4762
Dowel pins DIN EN ISO 8735

8x M16 / Strength class min. 8.8
4x Ø16

AERIAL FCC
2016.24.060.
 EXPLODED VIEW

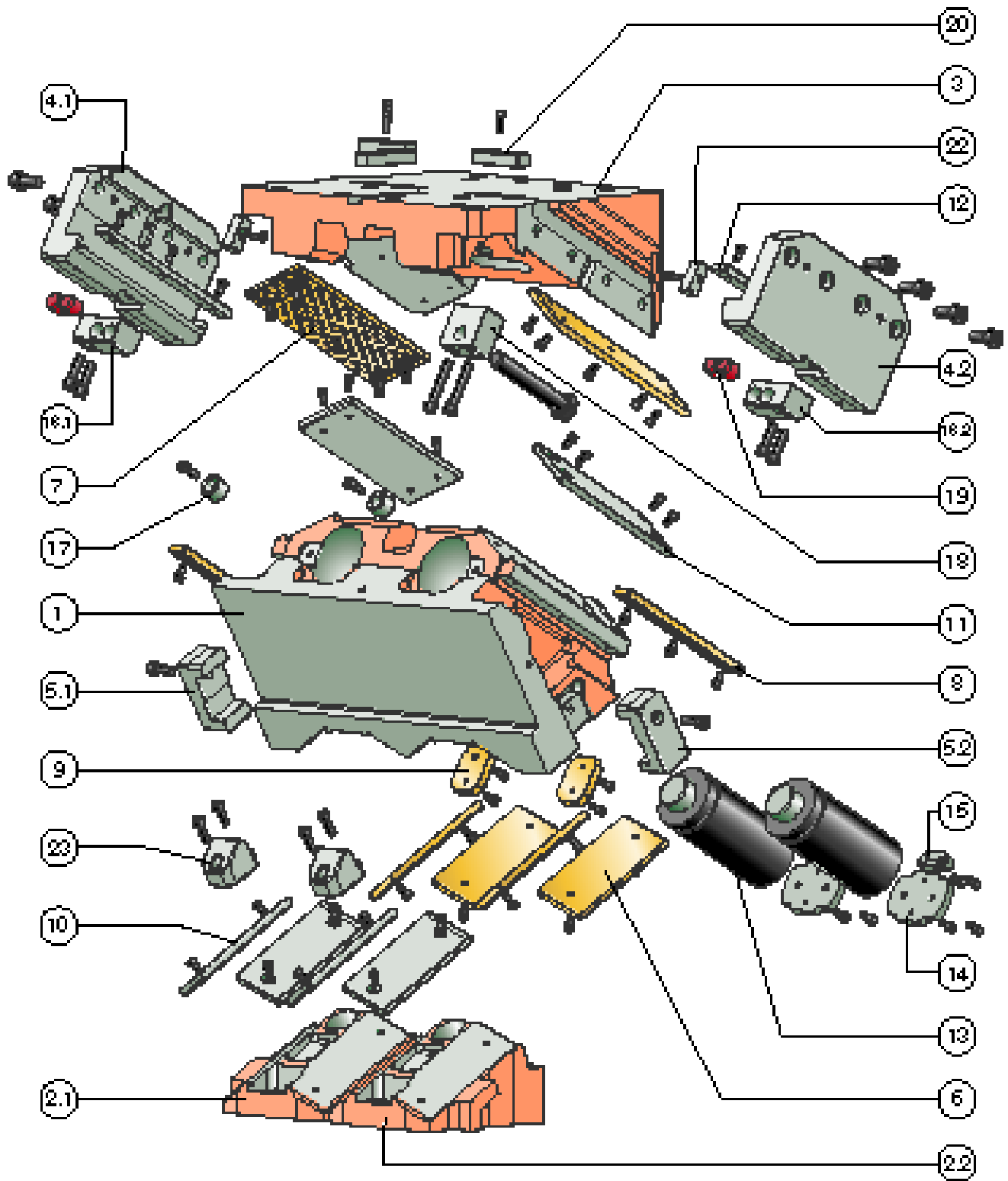

AERIAL FCC

2016.24.060.

PARTS LIST

Position	Piece	Designation	Material	spare part
1	1	Slider	GGG60	--
2				
2.1	1	Cam driver, left	GGG60	--
2.2	1	Cam driver, right	GGG60	--
3	1	Cam base	GGG60	--
4.1	1	Clamp, left	1.7225	x
4.2	1	Clamp, right	1.7225	x
5.1	1	Positive return, left	1.7225	x
5.2	1	Positive return, right	1.7225	x
6	4	Sliding plate	Bronze with solid lubricant	x
7	2	Sliding plate	Bronze with solid lubricant	x
8	2	Sliding plate	Bronze with solid lubricant	x
9*	2	Sliding plate	Bronze with solid lubricant	x
10	4	Sliding plate	1.7131	x
11	2	Sliding plate	1.7131	x
12	2	Sliding plate	1.7131	x
13	2	Gas spring	2487.12.03000.□□□	x
14	2	Stop plate	1.7225	x
15	2	Safety plate	1.1191	x
16.1	1	Cam slide stop, left	1.1191	x
16.2	1	Cam slide stop, right	1.1191	x
17	1	Spacer	1.1191	x
18	1	Lockout system		x
19	4	Damping element	Elastomer	x
20	3	Feather key (T-nut)		x
21				
22	2	Feather key (T-nut)		x
23*	2	Pre-acceleration		x
24				

* up to and including 45° with pre-acceleration

For inquiries or when ordering spare parts (x), we require the following data:

- ▶ Cam unit order no.
- ▶ Cam unit serial no.
- ▶ Item number / Designation / Spare part

AERIAL FCC

2016.24.060.

SYSTEM AND SURROUNDING FORCES

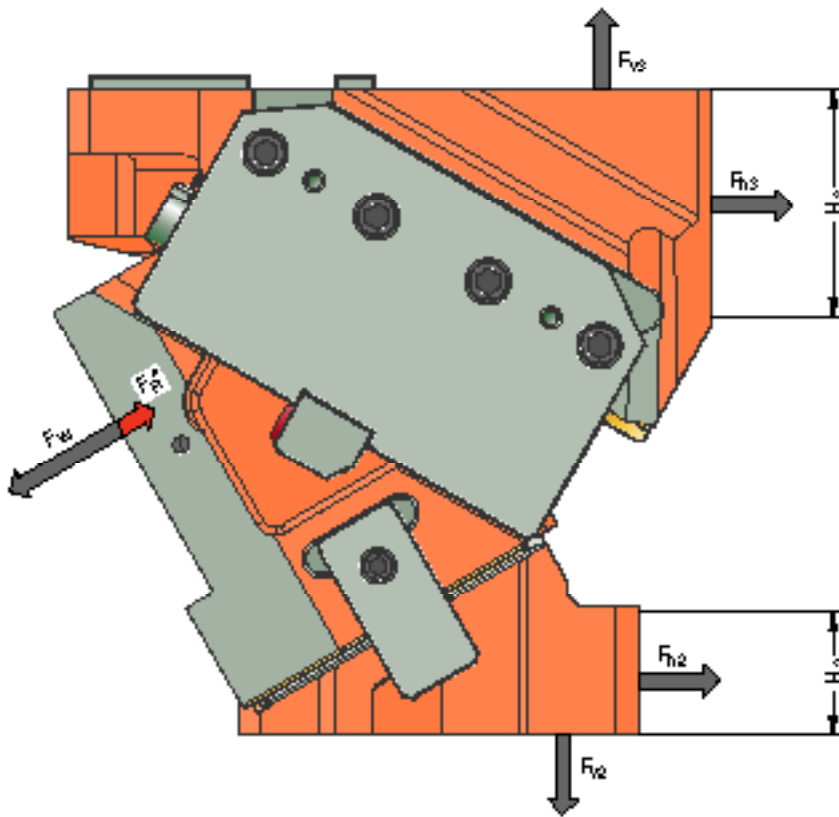

Order number	α [°]	F_W [kN]	F_R^* [kN]	F_{h2} [kN]	F_{v2} [kN]	F_{h3} [kN]	F_{v3} [kN]	H_2 [mm]	H_3 [mm]
2016.24.060.00.2000.00	0	1202	108.8	0	1009	1202	1009	40	220
2016.24.060.05.2000.00	5	1202	109.4	88	1005	1110	1110	40	210
2016.24.060.10.2000.00	10	1202	120.7	146	829	1038	1038	40	210
2016.24.060.15.2000.00	15	1202	121.3	218	813	943	1124	40	193
2016.24.060.20.2000.00	20	1202	121.7	288	791	842	1202	40	180
2016.24.060.25.2000.00	25	1202	125.0	293	629	796	1137	40	180
2016.24.060.30.2000.00	30	1202	125.0	347	601	694	1202	40	145
2016.24.060.35.2000.00	35	1202	125.0	321	459	663	1149	45	145
2016.24.060.40.2000.00	40	1202	125.0	360	429	561	1202	65	101
2016.24.060.45.2000.00	45	1202	125.0	309	309	541	1159	90	64
2016.24.060.50.2000.00	50	1202	125.0	335	281	437	1202	120	58
2016.24.060.55.2000.00	55	1202	125.0	264	185	426	1169	120	80
2016.24.060.60.2000.00	60	1202	125.0	279	161	322	1202	130	92
2016.24.060.65.2000.00	65	1202	125.0	192	90	316	1179	140	82
2016.24.060.70.2000.00	70	1202	125.0	99	36	312	1165	140	73
2016.24.060.75.2000.00	75	1202	125.0	102	27	210	1188	150	66

* Retraction force values correspond to the spring-generated retraction force at the working point

The forces F_{h2} , F_{v2} as well as F_{h3} , F_{v3} act on the tool environment at maximum working force F_W .

AERIAL FCC 2016.24.060. FORCE DIAGRAM

shouldered

Support with feather key

		Width 600 mm								
0°		65	65	65	70	70	70	65	65	65
Height 200 mm	40	90	216	302	385	473	385	302	216	90
	40	98	240	374	494	619	494	374	240	98
	40	107	265	422	586	756	586	422	265	107
	40	117	351	554	765	983	765	554	351	117
	40	126	406	662	927	1202	927	662	406	126

		Width 600 mm								
0°		65	65	65	70	70	70	65	65	65
Height 200 mm	40	45	63	68	93	118	93	68	63	45
	40	48	63	70	93	118	93	70	63	48
	40	51	63	70	93	118	93	70	63	51
	40	52	63	70	93	118	93	70	63	52
	40	53	63	70	93	118	93	70	63	53

		Width 600 mm								
5°		65	65	65	70	70	70	65	65	65
Height 200 mm	40	92	219	299	382	469	382	299	219	92
	40	101	262	378	498	623	498	378	262	101
	40	110	306	457	615	778	615	457	306	110
	40	121	361	563	772	990	772	563	361	121
	40	131	416	668	930	1202	930	668	416	131

		Width 600 mm								
5°		65	65	65	70	70	70	65	65	65
Height 200 mm	40	47	68	75	105	136	105	75	68	47
	40	49	68	79	105	136	105	79	68	49
	40	51	68	79	105	136	105	79	68	51
	40	52	68	79	105	136	105	79	68	52
	40	53	68	79	105	136	105	79	68	53

		Width 600 mm								
10°		65	65	65	70	70	70	65	65	65
Height 200 mm	40	95	216	296	379	465	379	296	216	95
	40	104	266	382	503	628	503	382	266	104
	40	114	315	468	626	791	626	468	315	114
	40	125	371	571	780	996	780	571	371	125
	40	135	426	675	933	1202	933	675	426	135

		Width 600 mm								
10°		65	65	65	70	70	70	65	65	65
Height 200 mm	40	48	74	82	117	154	117	82	74	48
	40	50	74	95	117	154	117	95	74	50
	40	51	74	95	117	154	117	95	74	51
	40	52	74	95	117	154	117	95	74	52
	40	53	74	95	117	154	117	95	74	53

		Width 600 mm								
15°		65	65	65	70	70	70	65	65	65
Height 200 mm	40	97	214	293	376	461	376	293	214	97
	40	107	270	386	507	632	507	386	270	107
	40	117	325	479	638	803	638	479	325	117
	40	129	380	580	787	1002	787	580	380	129
	40	140	435	681	937	1202	937	681	435	140

		Width 600 mm								
15°		65	65	65	70	70	70	65	65	65
Height 200 mm	40	50	79	89	130	172	130	89	79	50
	40	50	79	99	130	172	130	99	79	50
	40	51	79	109	130	172	130	109	79	51
	40	52	79	109	130	172	130	109	79	52
	40	53	79	109	130	172	130	109	79	53

		Width 600 mm								
20°		65	65	65	70	70	70	65	65	65
Height 200 mm	40	95	219	295	375	457	375	295	219	95
	40	106	275	392	514	641	514	392	275	106
	40	118	331	489	654	825	654	489	331	118
	40	131	375	580	793	1013	793	580	375	131
	40	145	419	670	931	1202	931	670	419	145

		Width 600 mm								
20°		65	65	65	70	70	70	65	65	65
Height 200 mm	40	51	85	96	143	191	143	96	85	51
	40	53	85	110	143	191	143	110	85	53
	40	55	85	110	143	191	143	110	85	55
	40	58	85	110	143	191	143	110	85	58
	40	60	85	110	143	191	143	110	85	60

		Width 600 mm								
25°		65	65	65	70	70	70	65	65	65
Height 200 mm	40	93	215	298	374	454	374	298	215	93
	40	106	280	399	522	650	522	399	280	106
	40	119	336	500	670	847	670	500	336	119
	40	134	370	580	798	1024	798	580	370	134
	40	147	403	660	926	1202	926	660	403	147

		Width 600 mm								
25°		65	65	65	70	70	70	65	65	65
Height 200 mm	40	53	91	103	156	211	156	103	91	53
	40	56	91	112	156	211	156	112	91	56
	40	59	91	112	156	211	156	112	91	59
	40	63	91	112	156	211	156	112	91	63
	40	68	91	112	156	211	156	112	91	68

AERIAL FCC 2016.24.060. FORCE DIAGRAM

shouldered

		Width 600 mm								
30°		65	65	65	70	70	70	65	65	65
Height 200 mm	40	90	207	300	373	450	373	300	207	90
	40	105	285	405	530	659	530	405	285	105
	40	119	341	510	686	868	686	510	341	119
	40	137	364	580	803	1035	803	580	364	137
	40	126	387	649	920	1202	920	649	387	126

		Width 600 mm								
35°		65	65	65	70	70	70	65	65	65
Height 200 mm	40	94	205	313	388	466	388	313	205	94
	40	105	294	415	541	671	541	415	294	105
	40	117	347	517	694	876	694	517	347	117
	40	140	378	590	811	1039	811	590	378	140
	40	154	409	663	928	1202	928	663	409	154

		Width 600 mm								
40°		65	65	65	70	70	70	65	65	65
Height 200 mm	40	97	202	306	402	482	402	306	202	97
	40	106	303	425	552	683	552	425	303	106
	40	114	354	524	701	884	701	524	354	114
	40	144	392	601	818	1043	818	601	392	144
	40	174	430	678	935	1202	935	678	430	174

		Width 600 mm								
45°		65	65	65	70	70	70	65	65	65
Height 200 mm	40	101	199	297	399	497	399	297	199	101
	40	106	307	435	563	695	563	435	307	106
	40	111	360	531	708	893	708	531	360	111
	40	147	405	611	825	1047	825	611	405	147
	40	183	451	692	942	1202	942	692	451	183

		Width 600 mm								
50°		65	65	65	70	70	70	65	65	65
Height 200 mm	40	92	184	276	372	471	372	276	184	92
	40	100	282	452	594	740	594	452	282	100
	40	109	380	563	754	952	754	563	380	109
	40	142	415	628	848	1077	848	628	415	142
	40	176	451	692	942	1202	942	692	451	176

		Width 600 mm								
55°		65	65	65	70	70	70	65	65	65
Height 200 mm	40	83	169	256	345	438	345	256	169	83
	40	95	257	420	589	764	589	420	257	95
	40	106	345	584	800	1012	800	584	345	106
	40	138	425	644	871	1107	871	644	425	138
	40	169	451	692	942	1202	942	692	451	169

Support with feather key

		Width 600 mm								
30°		65	65	65	70	70	70	65	65	65
Height 200 mm	40	54	97	111	169	230	169	111	97	54
	40	59	97	130	185	283	185	130	97	59
	40	63	97	130	185	283	185	130	97	63
	40	69	97	130	185	283	185	130	97	69
	40	76	97	130	185	283	185	130	97	76

		Width 600 mm								
35°		65	65	65	70	70	70	65	65	65
Height 200 mm	40	61	98	125	190	259	190	125	98	61
	40	67	98	132	220	300	220	132	98	67
	40	74	98	132	220	300	220	132	98	74
	40	74	98	132	220	300	220	132	98	74
	40	74	98	132	220	300	220	132	98	74

		Width 600 mm								
40°		65	65	65	70	70	70	65	65	65
Height 200 mm	40	67	101	139	211	287	211	139	101	67
	40	67	101	141	211	318	211	141	101	67
	40	67	101	141	211	350	211	141	101	67
	40	67	101	141	211	350	211	141	101	67
	40	67	101	141	211	350	211	141	101	67

		Width 600 mm								
45°		65	65	65	70	70	70	65	65	65
Height 200 mm	40	67	108	152	186	315	186	152	108	67
	40	67	108	153	196	336	196	153	108	67
	40	67	108	153	240	357	240	153	108	67
	40	67	108	153	240	357	240	153	108	67
	40	67	108	153	240	357	240	153	108	67

		Width 600 mm								
50°		65	65	65	70	70	70	65	65	65
Height 200 mm	40	65	145	164	242	323	242	164	145	65
	40	65	164	168	275	370	275	168	164	65
	40	65	176	168	309	417	309	168	176	65
	40	65	176	168	309	445	309	168	176	65
	40	65	176	168	309	445	309	168	176	65

		Width 600 mm								
55°		65	65	65	70	70	70	65	65	65
Height 200 mm	40	67	115	175	211	330	211	175	115	67
	40	67	115	196	302	403	302	196	115	67
	40	67	115	196	316	466	316	196	115	67
	40	67	115	196	316	466	316	196	115	67
	40	67	115	196	316	466	316	196	115	67

AERIAL FCC 2016.24.060. FORCE DIAGRAM

shouldered

		Width 600 mm								
60°		65	65	65	70	70	70	65	65	65
Height 200 mm	40	74	155	235	318	404	318	235	155	74
	40	89	232	376	525	679	525	376	232	89
	40	104	310	517	731	954	731	517	310	104
	40	133	414	660	894	1136	894	660	414	133
	40	163	451	692	942	1202	942	692	451	163

Support with feather key

		Width 600 mm								
60°		65	65	65	70	70	70	65	65	65
Height 200 mm	40	74	128	186	240	338	240	186	128	74
	40	74	128	223	265	437	265	223	128	74
	40	74	128	223	378	536	378	223	128	74
	40	74	128	223	380	614	380	223	128	74
	40	74	128	223	380	614	380	223	128	74

65°

		Width 600 mm								
65°		65	65	65	70	70	70	65	65	65
Height 200 mm	40	71	153	235	319	408	319	235	153	71
	40	86	231	376	527	684	527	376	231	86
	40	100	309	518	736	961	736	518	309	100
	40	122	397	671	913	1156	913	671	397	122
	40	145	466	702	947	1202	947	702	466	145

65°

		Width 600 mm								
65°		65	65	65	70	70	70	65	65	65
Height 200 mm	40	71	133	203	291	383	291	203	133	71
	40	77	133	251	383	519	383	251	133	77
	40	77	133	251	392	643	392	251	133	77
	40	77	133	251	392	643	392	251	133	77
	40	77	133	251	392	643	392	251	133	77

70°

		Width 600 mm								
70°		65	65	65	70	70	70	65	65	65
Height 200 mm	40	68	151	234	321	411	321	234	151	68
	40	82	230	377	530	689	530	377	230	82
	40	96	308	520	740	968	740	520	308	96
	40	112	380	648	926	1176	926	648	380	112
	40	127	451	713	953	1202	953	713	451	127

70°

		Width 600 mm								
70°		65	65	65	70	70	70	65	65	65
Height 200 mm	40	67	151	220	321	411	321	220	151	67
	40	82	173	280	437	601	437	280	173	82
	40	96	175	280	439	640	439	280	175	96
	40	124	178	280	439	640	439	280	178	124
	40	124	178	280	439	640	439	280	178	124

75°

		Width 600 mm								
75°		65	65	65	70	70	70	65	65	65
Height 200 mm	40	64	149	234	322	414	322	234	149	64
	40	79	228	378	533	694	533	378	228	79
	40	93	307	522	744	975	744	522	307	93
	40	101	363	624	896	1178	896	624	363	101
	40	110	419	723	958	1202	958	723	419	110

75°

		Width 600 mm								
75°		65	65	65	70	70	70	65	65	65
Height 200 mm	40	64	149	234	273	414	273	234	149	64
	40	79	149	308	350	578	350	308	149	79
	40	93	149	378	513	743	513	378	149	93
	40	104	149	372	548	862	548	372	149	104
	40	104	149	366	548	832	548	366	149	104

AERIAL FCC
2016.24.006./008./011.
 ASSEMBLY INSTRUCTIONS

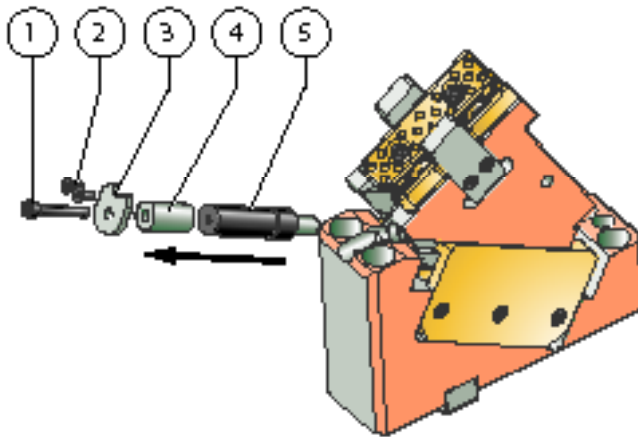

Step 1

- ▶ Remove screws (1+2)
- ▶ Remove stop plate (3) of the gas spring
- ▶ Remove spacer (4) and gas spring (5) from the bore

CAUTION

The gas spring may only be removed if the spring is released. After removing the stop plate for the gas spring, observe that there is a risk of crushing between the cam unit driver and the cam unit base due to independent movement of the cam unit driver.

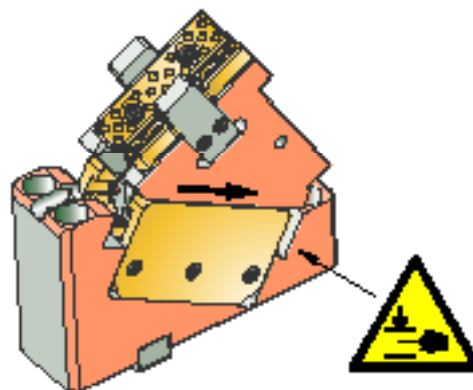

Step 2

- ▶ Slide the cam unit driver into the front position

CAUTION

Risk of crushing between the cam unit driver and the cam unit base by movement of the cam unit driver.

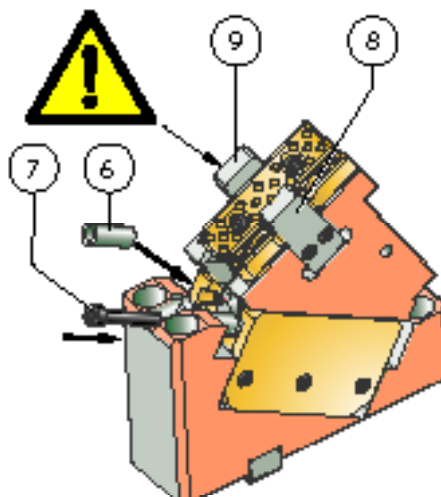

Step 3

- ▶ Insert the lockout sleeve (6)
- ▶ Secure the cam unit driver with the screw (7)

This position corresponds to the closed position (working position) in the tool.

CAUTION

In the classic tool setup process (pressing the cam driver in the die), the positive return left (9) and right (8) must additionally be removed in order to avoid damaging the cam unit, cam driver and die.

AERIAL FCC

2016.24.006./008./011.

ASSEMBLY INSTRUCTIONS

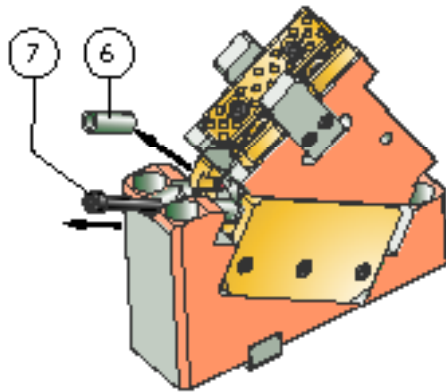

Step 4

Restore the cam unit function after completion of the work (setup, work surface machining).

- ▶ Remove screw (7)
- ▶ Remove the lockout sleeve (6)

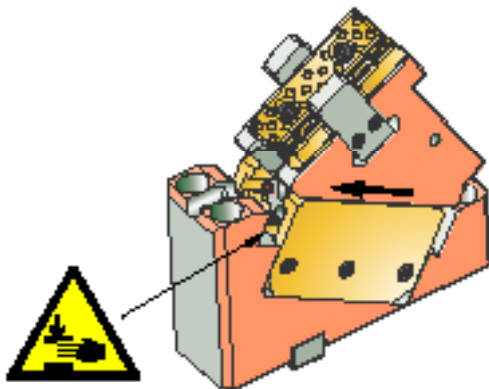

Step 5

- ▶ Slide the cam unit driver backwards

CAUTION

Risk of crushing between the cam unit driver and the cam unit base by movement of the cam unit driver.

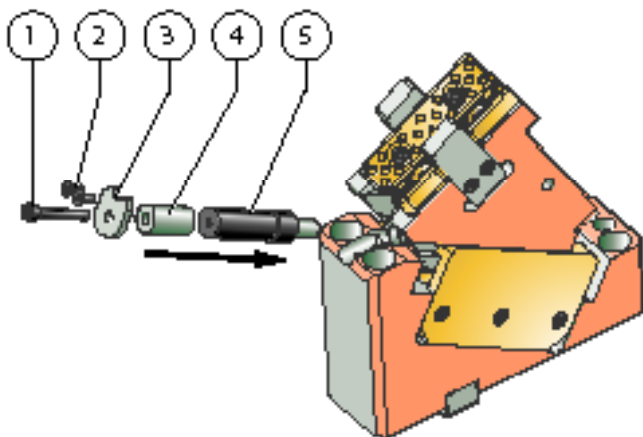

Step 6

- ▶ Insert gas spring (5) and spacer (4)
- ▶ Insert stop plate (3) for gas spring and secure with screws (2+1)

Screws must be secured against loosening by means of adhesive or suitable lock washers.

AERIAL FCC

2016.24.015./018./022./026./033./040./050.

ASSEMBLY INSTRUCTIONS

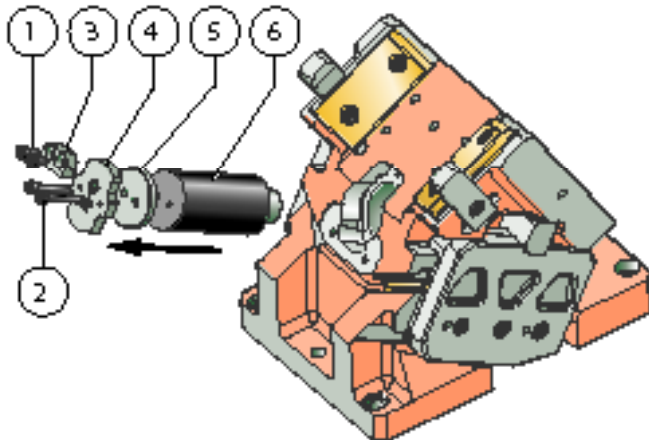

Step 1

- ▶ Remove screws (1 + 2)
- ▶ Remove lock washer (3)
- ▶ Remove the stop plate (4) of the gas spring
- ▶ Remove spacer (5) only up to cam unit width 260 mm) and gas spring (6) from the bore

CAUTION

The gas spring may only be removed if the spring is released. After removing the stop plate for the gas spring, observe that there is a risk of crushing between the cam unit driver, stop, and cam unit base due to independent movement of the cam unit driver.

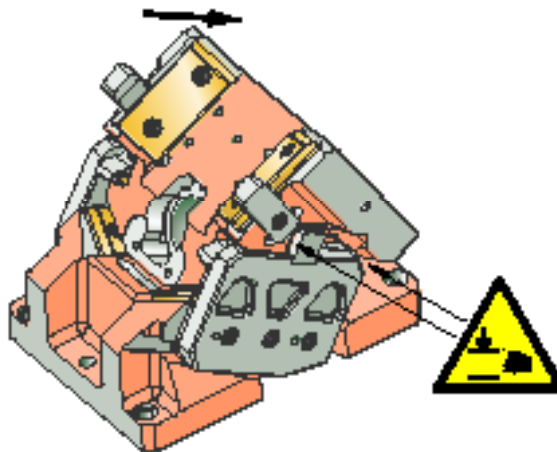

Step 2

- ▶ Slide the cam unit driver into the front position

CAUTION

Risk of crushing between the cam unit driver, stop, and cam unit base by movement of the cam unit driver.

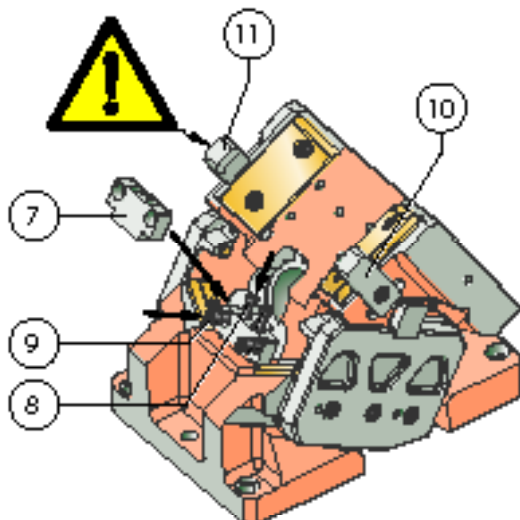

Step 3

- ▶ Insert lockout system (7) and fix with screws (8)
- ▶ Insert the spacer (not shown) between the lockout and the cam unit driver (cam unit width 110 and 150 mm)
- ▶ Fix the cam unit driver with the screws (9)

This position corresponds to the closed position (working position) in the die.

CAUTION

In the classic tool setup process (pressing the cam driver in the die), the positive return right (10) and left (11) must be removed in order to avoid damaging the cam unit, cam driver and die.

AERIAL FCC

2016.24.015./018./022./026./033./040./050.

ASSEMBLY INSTRUCTIONS

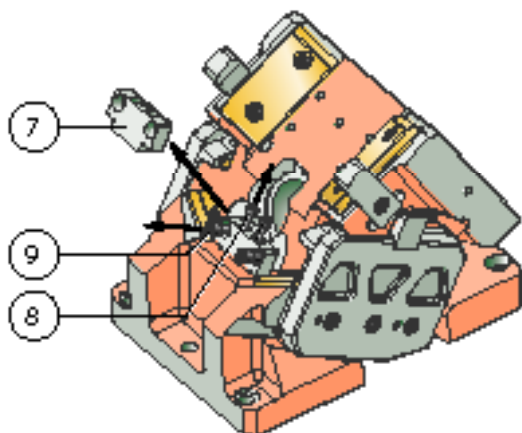

Step 4

Restore the cam unit function after completion of the work (setup, work surface machining).

- ▶ Remove screws (9)
- ▶ Remove spacer (not shown) (cam unit width 110 and 150 mm)
- ▶ Loosen the screws (8) and remove the lockout system (7)

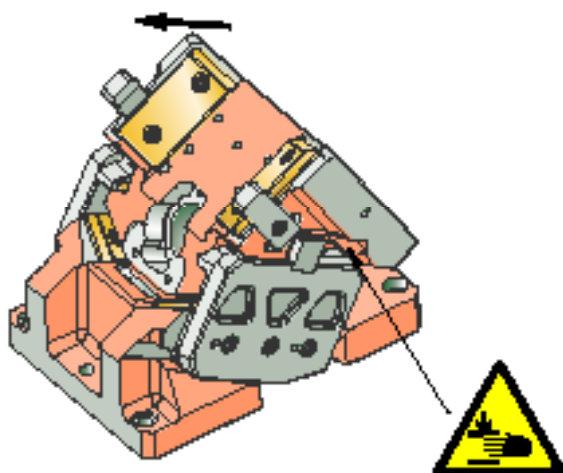

Step 5

- ▶ Slide the cam unit driver backwards

CAUTION

Risk of crushing between the cam unit driver, stop, and cam unit base by movement of the cam unit driver.

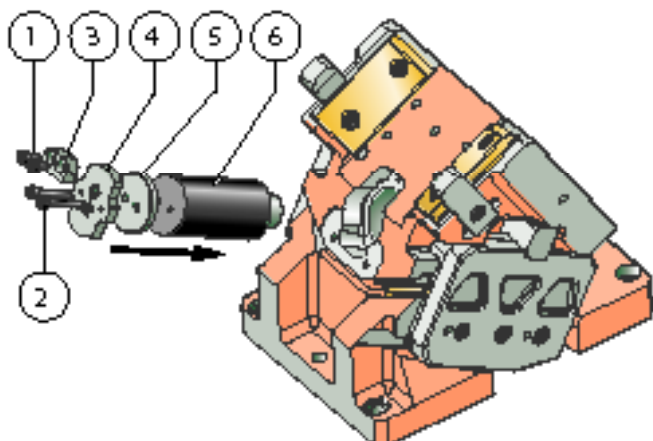

Step 6

- ▶ Insert the gas spring (6) and the spacer (5) (only up to the slide width 260 mm)
- ▶ Insert the stop plate (4) for the gas spring
- ▶ Insert lock washer (3) (from cam unit width 220m)
- ▶ Fix stop plate and lock washer with screws (2 + 1)

Screws must be secured against loosening by means of adhesive or suitable lock washers.

AERIAL FCC

2016.24.060.

ASSEMBLY INSTRUCTIONS

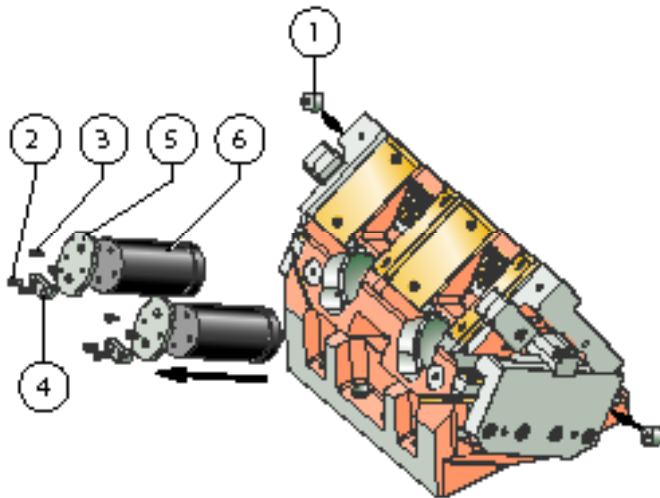

Step 1

- ▶ Insert the spacer (1) and secure with screws (not shown)
- ▶ Remove screws (2 + 3)
- ▶ Remove lock washers (4)
- ▶ Remove the stop plates (5) of the gas springs
- ▶ Remove the gas springs (6) from the bore

CAUTION

The gas spring may only be removed if the spring is released. After removing the stop plate for the gas spring, observe that there is a risk of crushing between the cam unit driver, stop, and cam unit base due to independent movement of the cam unit driver.

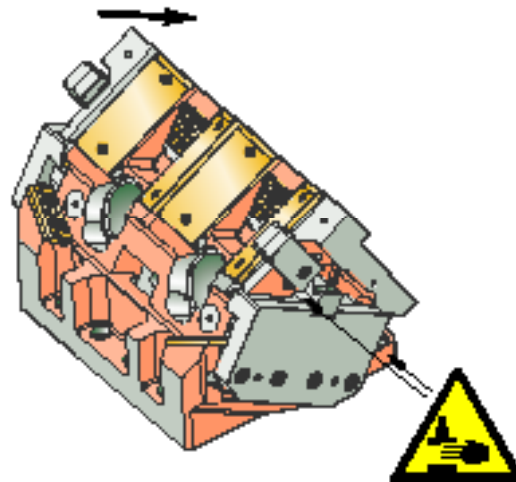

Step 2

- ▶ Slide the cam unit driver into the front position

CAUTION

Risk of crushing between the cam unit driver, stop, and cam unit base by movement of the cam unit driver.

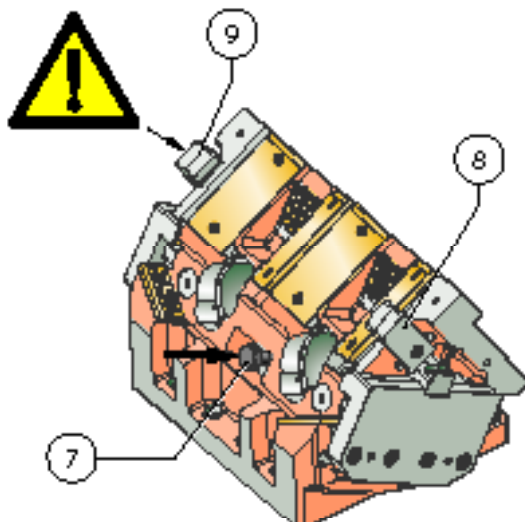

Step 3

- ▶ Fix cam unit driver with lockout screw (7) in the front position

This position corresponds to the closed position (working position) in the tool.

CAUTION

In the classic tool setup process (pressing the cam driver in the tool), the positive return right (8) and left (9) must be removed in order to avoid damaging the cam unit, cam driver and tool.

AERIAL FCC
2016.24.060.
 ASSEMBLY INSTRUCTIONS

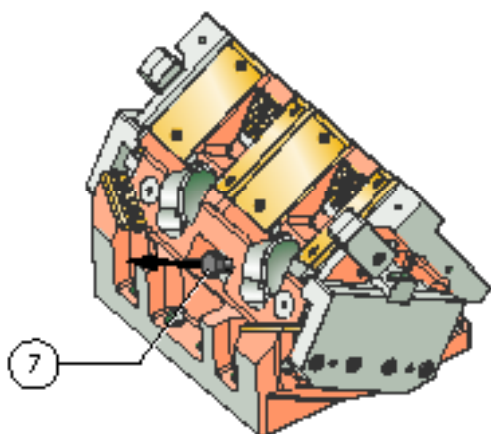

Step 4

Restore the cam unit function after completion of the work (setup, work surface machining).

- ▶ Remove lockout screws (7)

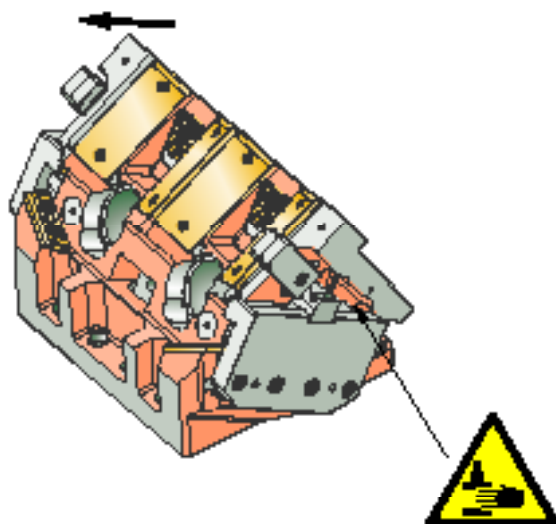

Step 5

- ▶ Slide the cam unit driver backwards

CAUTION

Risk of crushing between the cam unit driver, stop, and cam unit base by movement of the cam unit driver.

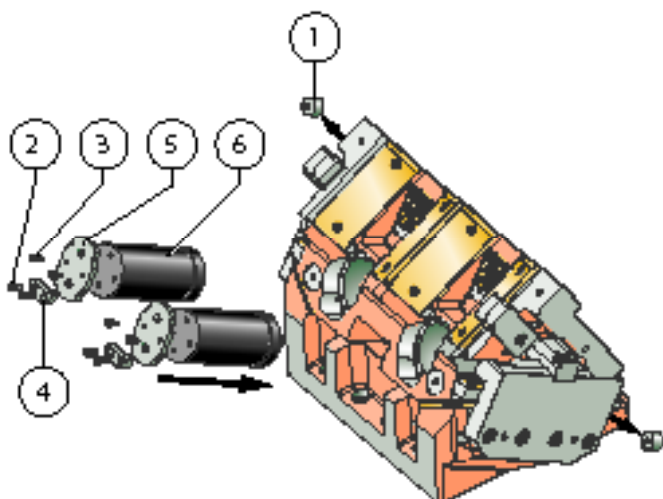

Step 6

- ▶ Insert gas springs (6) in bores
- ▶ Insert the stop plates (5) for the gas springs
- ▶ Insert lock washers (4)
- ▶ Fix stop plate and lock washer with screws (3 + 2)
- ▶ Remove spacer (1)

Screws must be secured against loosening by means of adhesive or suitable lock washers.

AERIAL FCC

2016.24.

ASSEMBLY IN THE TOOL

Series 2016.24. cam units are designed so that the screws and pins for positioning and securing the cam unit components in the die are accessible in the open position of the cam unit. This accessibility can be restricted or completely prevented by tooling on the cam unit working surface. In such cases, the disassembly / assembly of the fitted cam unit is possible by disassembling the clamp:

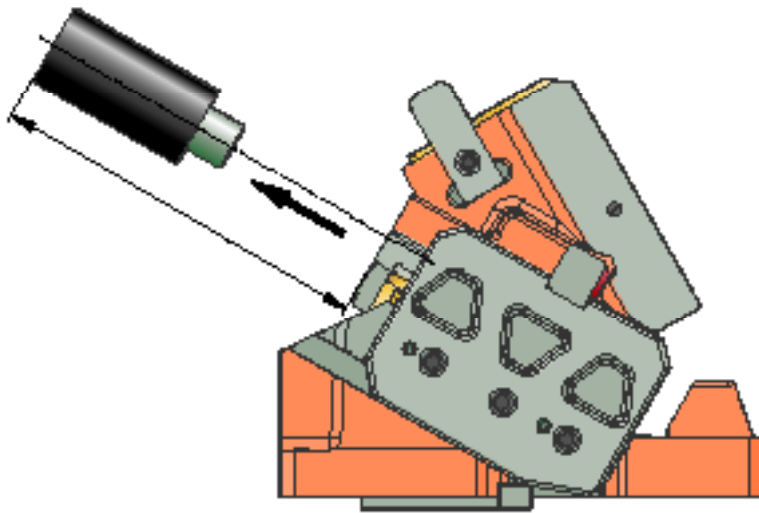

Step 1

- ▶ Remove the gas spring before disassembling the cam unit. In the die, the corresponding mechanical clearances must be taken into account backwards.

CAUTION

The gas spring may only be removed if the spring is released. After removing the stop plate for the gas spring, observe that there is a risk of crushing between the cam unit driver and the cam unit base due to independent movement of the cam unit driver.

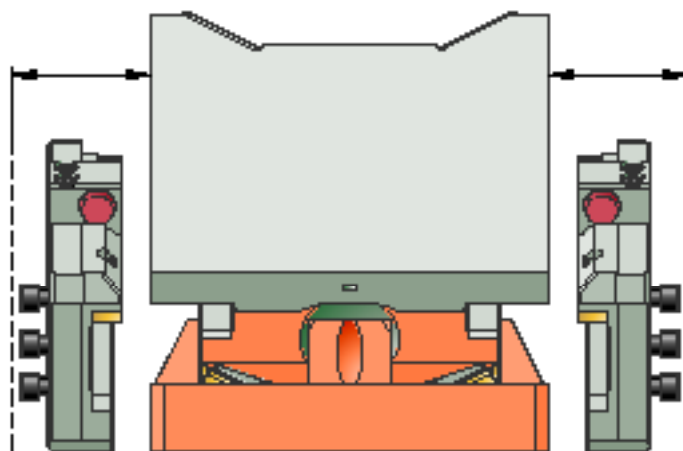

Step 2

- ▶ Loosen and remove the left and right guide clamps. No removal of positioning pins required! In the die, the corresponding mechanical clearances must be provided at the sides.

AERIAL FCC

2016.24.

ASSEMBLY IN THE TOOL

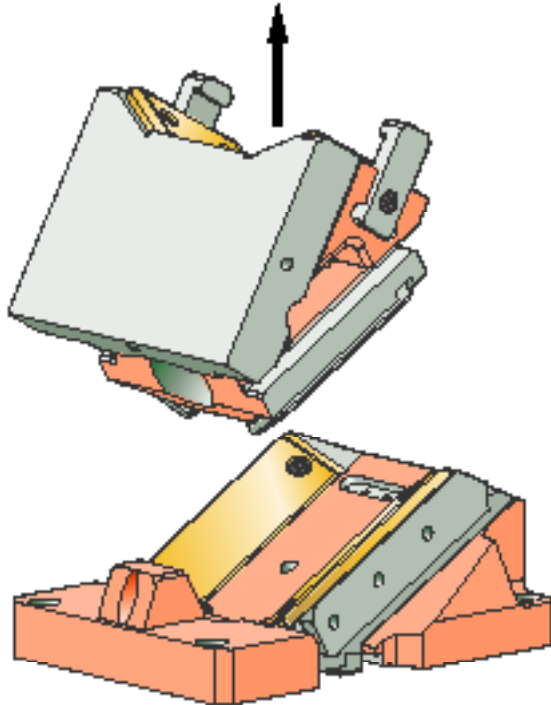

Step 3

- Lift the (equipped) cam unit upwards.
The cam unit base can remain in the upper die

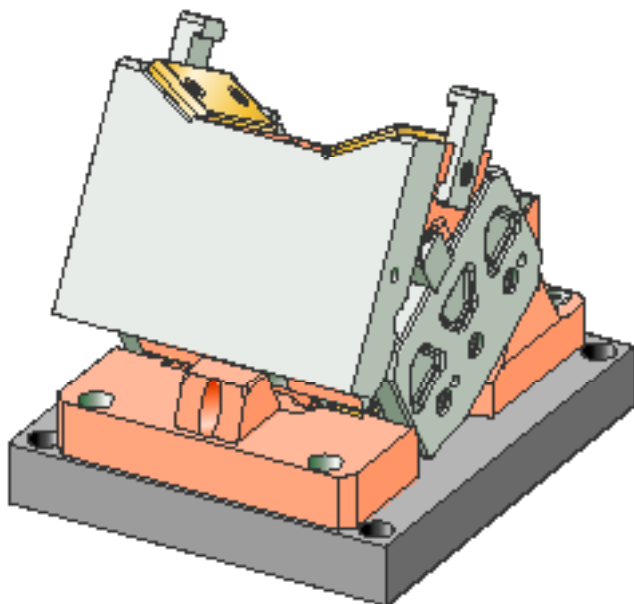

In the case of installation space problems in the die, an additional mounting plate can also be used as an alternative. The cam unit is positioned and fixed on this mounting plate, the positioning and fastening possibilities to the die lie outside the compact cam unit structure, and are thus easily accessible from above for the necessary fitting aids. Mounting plates are to be provided by the tool shop if necessary, they are not included in the delivery scope of FIBRO cam units.

INTRODUCTION AND TABLE OF CONTENTS

ENGINEERING

2016.24. AERIAL FCC BAK

DAIMLER, VOLVO,
VOLKSWAGEN GROUP

2016.25. AERIAL FCC BAK

DAIMLER, VOLVO,
VOLKSWAGEN GROUP

2016.207. AERIAL ECO LINE

2016.208. AERIAL ECO LINE

CUSTOMER-SPECIFIC SERVICES

APPENDIX

EMERGENCY SITUATION / CONTACTS



**AERIAL FCC
2016.25.**



AERIAL FCC 2016.25.

FIBRO FCC cam units series 2016.25. are a continuation of the FCC Series from a width of 700 mm and higher. This series also impresses with its excellent load bearing as well as the highest precision even after a high number of pressing.

All sliding elements of the cam unit correspond to the VDI standard. The sliding elements are shouldered to absorb thrust. The return springs are accessible from the back side of the cam unit, so that they can be dismantled from the die without removing the cam unit.

FIBRO FCC cam units series 2016.25. meet the requirements of the BAK product specifications.

Various ordering options are available for FIBRO FCC cam units series 2016.25.

- The working surface can be optionally equipped with or without shoulder
- Up to an angle of 45°, the cam units are equipped with a pre-acceleration, whereby a choice can be made between roll or plate pre-acceleration.

FIBRO cam units series 2016.25. are machined on the outer surfaces of the back side of the working surface. This makes it possible to machine the working surface of the cam unit with a simple clamping.

FIBRO FCC cam units series 2016.25. are, of course, available ex works, manufactured according to customer requirements. This meets the highest requirements of modern tool and die makers.

Design features:

- Double prismatic guide against cam driver, square positioned guiding elements against cam base.
- Sliding surfaces hardened steel / bronze with solid lubricant
- Gas springs
- Positive locking connections

FIBRO FCC cam units series 2016.25. are available in the widths from 700 to 1050 mm and in the angular variants 0° to 75 ° (gradation 5°).

Order number	Width [mm]	Performance class [kN]*	Page
2016.25.070.□□.□000.02	700	1600	179
2016.25.075.□□.□000.02	750	1600	179
2016.25.080.□□.□000.02	800	1700	189
2016.25.085.□□.□000.02	850	1700	189
2016.25.090.□□.□000.02	900	1800	199
2016.25.095.□□.□000.02	950	1800	199
2016.25.100.□□.□000.02	1000	2000	209
2016.25.105.□□.□000.02	1050	2000	209

* For exact power values, please refer to the force diagrams of the corresponding cam units

Order options:

- .1000 Working surface standard, roll pre-acceleration
- .2000 Working surface offset (shoulder on working surface), roll pre-acceleration
- .3000 Working surface standard, plate pre-acceleration
- .4000 Working surface offset (shoulder on working surface), plate pre-acceleration

Ordering example:

FIBRO cam unit FCC, aerial, width 850 mm	=	2016.25.085.□□.□000.02
Cam unit angle $\alpha = 35^\circ$	=	35.
Working surface offset (shoulder on working surface), plate pre-acceleration	=	4000.
Order number	=	2016.25.085. 35. 4000.02



AERIAL FCC 2016.25.070./075.

Working width: 700/750 mm
Performance class: 1600 kN

AERIAL FCC
2016.25.070./075.
 SIZE TABLE

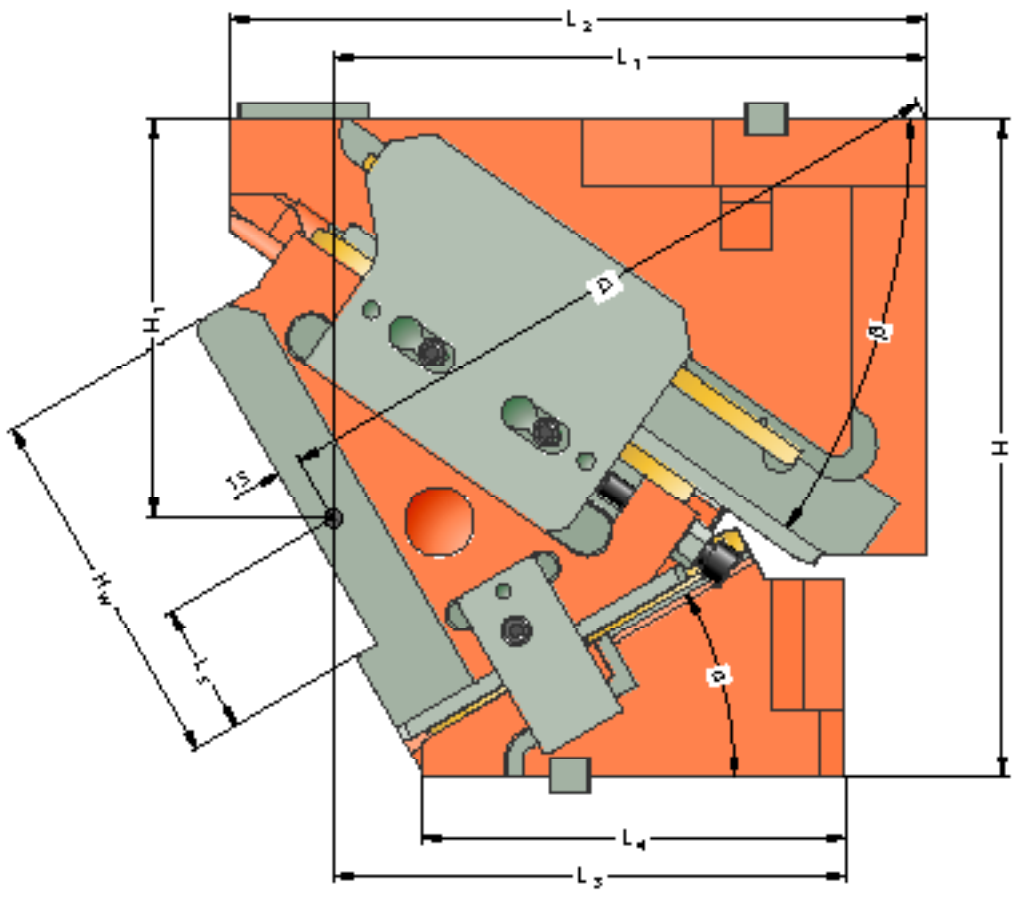
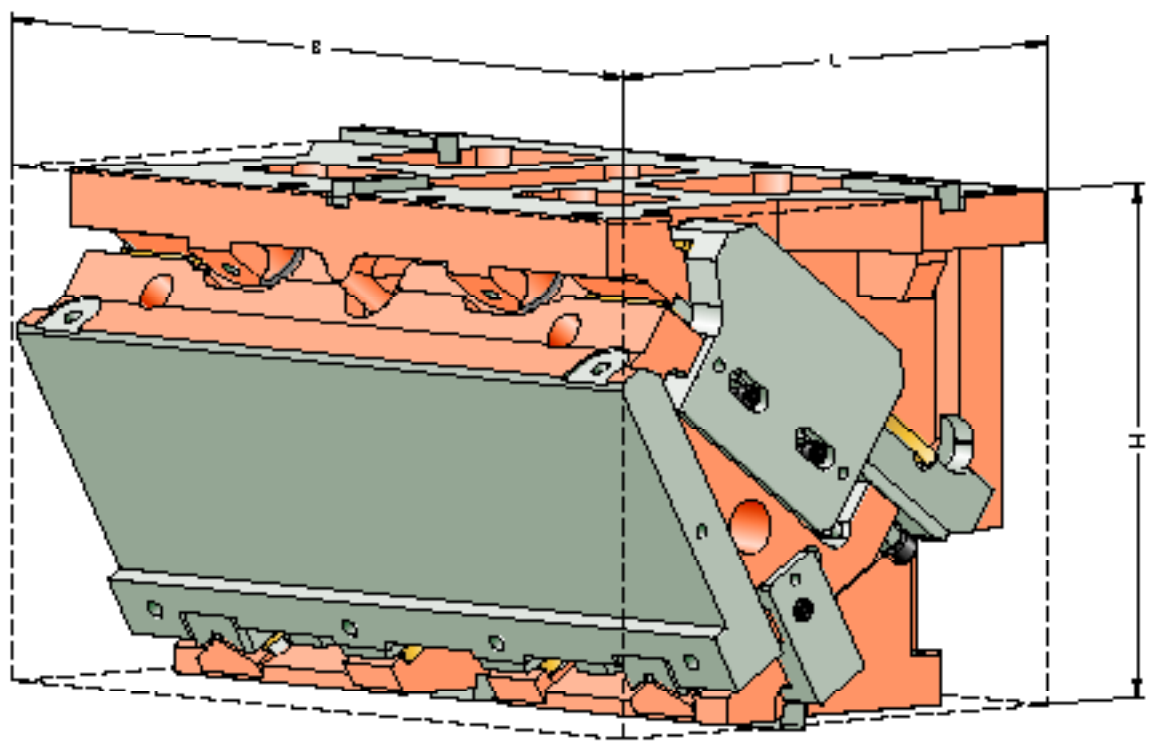

AERIAL FCC

2016.25.070./075.

SIZE TABLE

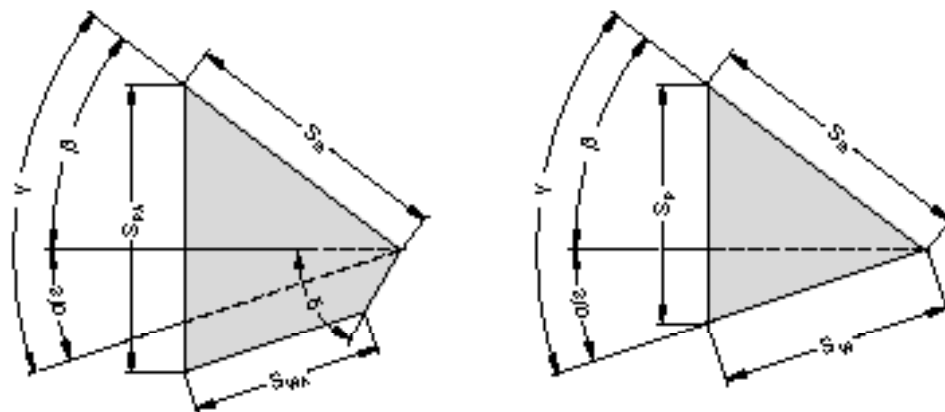

Order No.	L**	B***	H	H ₁	H _W	L ₁	L ₂	L ₃	L ₄	L ₅	D*	α	β	δ	S _W *	S _{WA} *	S _S	S _P *	S _{PA} *
2016.25.7□0.	[mm]	[mm]	[mm]	[mm]	[mm]	[mm]	[mm]	[mm]	[mm]	[mm]	[mm]	[°]	[°]	[°]	[mm]	[mm]	[mm]	[mm]	[mm]
00.□000.02	395	7□0	400	208	220	365	370	280	305	80	395	0	50	45	-	45.7	100	-	95.2
05.□000.02	409.1	7□0	400	209	220	367.03	385	297.03	308	80	413.8	5	45	50	-	53.8	100	-	95.8
10.□000.02	428	7□0	400	208.61	220	374.12	385	304.12	302	80	434.7	10	45	45	-	56.6	100	-	95.5
15.□000.02	441.4	7□0	400	218.84	220	376.22	405	316.22	300	80	450	15	40	50	-	65.5	100	-	97.2
20.□000.02	449.3	7□0	400	229.69	220	373.27	410	298.27	270	80	459.3	20	40	45	-	68.8	100	-	99.8
25.□000.02	456.6	7□0	400	236.16	220	370.22	420	305.22	263	80	465.3	25	35	50	-	74.3	95	-	98.4
30.□000.02	458	7□0	400	243.22	220	362.01	425	312.01	258	80	465.1	30	35	45	-	79.5	95	-	103.2
35.□000.02	458.5	7□0	400	250.86	220	353.6	440	318.6	253	80	463.5	35	30	50	-	81.4	85	-	97.5
40.□000.02	462.9	7□0	400	259.08	220	349.93	450	324.93	247	80	464.6	40	25	55	-	93.0	85	-	104.0
45.□000.02	461.2	7□0	400	262.83	220	340.96	455	330.96	243	80	456.9	45	20	60	-	100.2	80	-	105.7
50.□000.02	483.2	7□0	400	267.09	220	356.64	480	336.64	264	80	463.9	50	10	-	107.2	-	70	94.3	-
55.□000.02	475.1	7□0	400	271.83	220	331.93	460	341.93	260	80	443.1	55	10	-	103.0	-	60	94.8	-
60.□000.02	480	7□0	400	277.01	220	316.78	470	326.78	237	80	428.3	60	10	-	108.3	-	55	103.4	-
65.□000.02	490	7□0	400	282.6	220	281.17	440	331.17	234	80	404.9	65	0	-	106.5	-	45	96.5	-
70.□000.02	505	7□0	400	288.54	220	265.05	435	335.05	232	80	391.8	70	0	-	117.0	-	40	109.9	-
75.□000.02	515	7□0	400	294.81	220	248.39	425	338.39	230	80	379.1	75	0	-	115.9	-	30	112.0	-

* Values rounded

** Values L, D measured for option with shouldered working surface

*** 7□0 = 700 or 750 mm

Mounting cam base:

Hexagon socket head cap screws DIN EN ISO 4762

8x M20 / Strength class min. 8.8

Dowel pins DIN EN ISO 8735

2x ø16

Mounting cam driver:

Hexagon socket head cap screws DIN EN ISO 4762

2x4 M16 / Strength class min. 8.8

Dowel pins DIN EN ISO 8735

2x2 ø12

AERIAL FCC
2016.25.070./075.
 EXPLODED VIEW

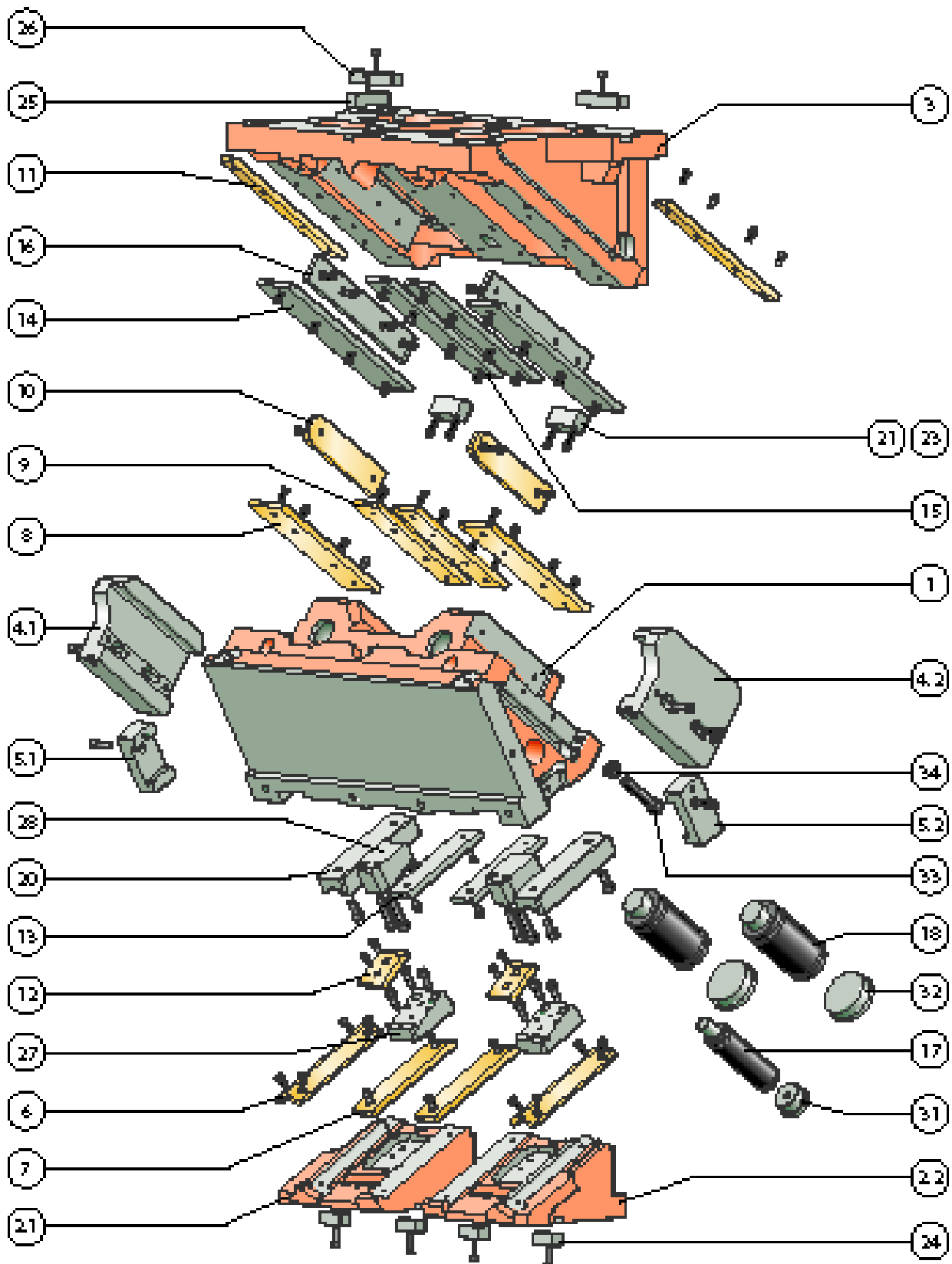

AERIAL FCC

2016.25.070./075.

PARTS LIST

Position	Piece	Designation	Material	spare part
1	1	Slider		
2.1	1	Driver, left		
2.2	1	Driver, right		
3	1	Slider base		
4.1	1	Clamp, left		x
4.2	1	Clamp, right		x
5.1	1	Positive return, left		x
5.2	1	Positive return, right		x
6	4	Sliding plate VDI	Bronze with solid lubricant	x
7	2	Sliding plate VDI	Bronze with solid lubricant	x
8	2	Sliding plate VDI	Bronze with solid lubricant	x
9	2	Sliding plate VDI	Bronze with solid lubricant	x
10	2	Sliding plate VDI	Bronze with solid lubricant	x
11	2	Sliding plate VDI	Bronze with solid lubricant	x
12**	2	Sliding plate VDI	Bronze with solid lubricant	x
13	2	Sliding plate VDI	Steel	x
14	2	Sliding plate VDI	Steel	x
15	2	Sliding plate VDI	Steel	x
16	2	Sliding plate VDI	Steel	x
17	1	Gas spring	2487.12.00750.125	x
18	2	Gas spring	2487.12.02400. □□□	x
19				x
20	2	Prismatic guide		x
21	2	Stop plate		x
22				
23	2	Damper		x
24	4	Feather key (T-nut)		x
25	1	Feather key (T-nut)		x
26	2	Feather key (T-nut)		x
27**	2	Construction piece		x
28**	2	Slide pad		x
29* (not shown)	2	Curve wedge		x
30* (not shown)	2	Roller block		x
31	1	Locking screw		x
32	2	Locking screw		x
33	2	Ball-head screw		x
34	2	Hexagon nut		x

up to and including 45° with pre-acceleration

Optionally:

* Roll pre-acceleration (.1000. /.2000.)

** Plate pre-acceleration (.3000. /.4000.)

For inquiries or when ordering spare parts (x), we require the following data:

- Cam unit order no.
- Cam unit serial number
- Item number / Designation / Spare part

AERIAL FCC

2016.25.070./075.

SYSTEM AND SURROUNDING FORCES

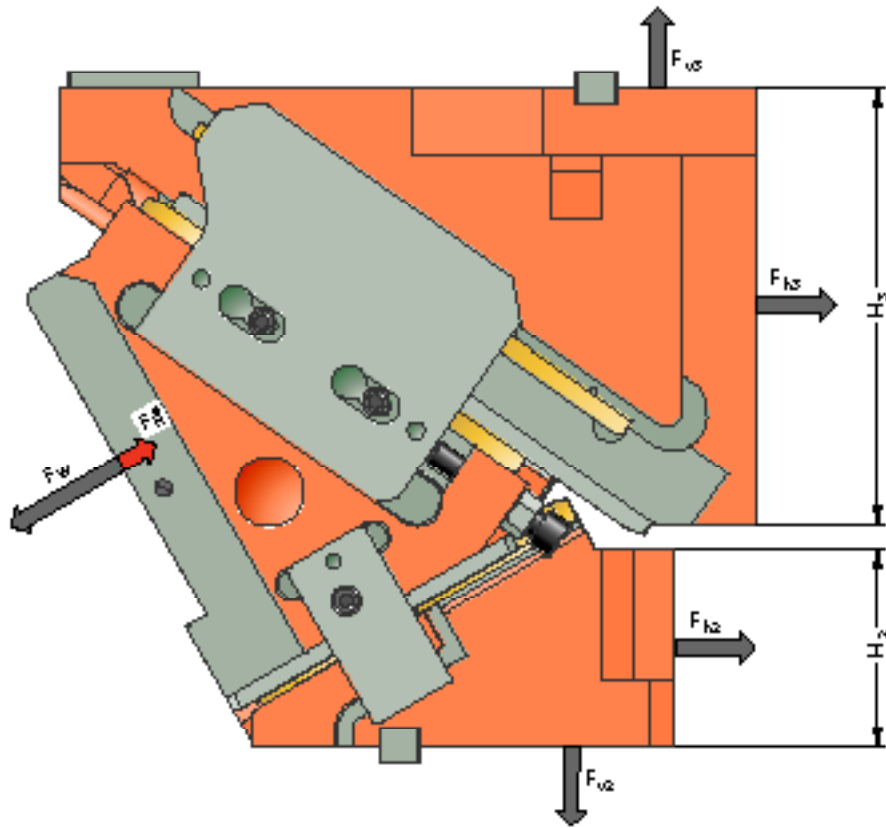

Order number	α [°]	F_W [kN]	F_R^* [kN]	F_{h2} [kN]	F_{v2} [kN]	F_{h3} [kN]	F_{v3} [kN]	H_2 [mm]	H_3 [mm]
2016.25.07□.00.□000.02	0	1600	101.0	0	1343	1600	1343	40	300
2016.25.07□.05.□000.02	5	1600	102.9	117	1337	1477	1477	40	275
2016.25.07□.10.□000.02	10	1600	114.5	195	1103	1381	1381	75	275
2016.25.07□.15.□000.02	15	1600	116.1	290	1082	1256	1496	80	255
2016.25.07□.20.□000.02	20	1600	131.4	316	868	1188	1415	90	245
2016.25.07□.25.□000.02	25	1600	130.3	390	837	1060	1513	110	215
2016.25.07□.30.□000.02	30	1600	151.2	373	646	1013	1446	120	210
2016.25.07□.35.□000.02	35	1600	147.2	428	611	883	1529	140	210
2016.25.07□.40.□000.02	40	1600	148.1	480	572	746	1600	150	190
2016.25.07□.45.□000.02	45	1600	146.2	528	528	604	1659	170	170
2016.25.07□.50.□000.02	50	1600	124.1	708	594	321	1819	170	120
2016.25.07□.55.□000.02	55	1600	137.6	611	428	307	1739	180	115
2016.25.07□.60.□000.02	60	1600	170.7	504	291	296	1677	180	110
2016.25.07□.65.□000.02	65	1600	135.5	676	315	0	1765	190	85
2016.25.07□.70.□000.02	70	1600	163.1	547	199	0	1703	205	85
2016.25.07□.75.□000.02	75	1600	191.8	414	111	0	1656	220	85

* Retraction force values correspond to the spring-generated retraction force at the working point point

The forces F_{h2} , F_{v2} as well as F_{h3} , F_{v3} act on the tool environment at maximum working force F_W .

AERIAL FCC

2016.25.070./075.

FORCE DIAGRAM

shouldered

		Width 700 mm						
		105	105	105	70	105	105	105
Height 225 mm	45	60	77	211	654	211	77	60
	45	72	97	336	1044	336	97	72
	45	83	117	543	1435	543	117	83
	45	94	136	653	1633	653	136	94
	45	105	156	451	1207	451	156	105

		Width 700 mm						
		105	105	105	70	105	105	105
Height 225 mm	45	65	84	242	732	242	84	65
	45	78	108	370	1100	370	108	78
	45	89	129	566	1469	566	129	89
	45	99	143	650	1620	650	143	99
	45	108	158	458	1219	458	158	108

		Width 700 mm						
		105	105	105	70	105	105	105
Height 225 mm	45	69	92	274	810	274	92	69
	45	83	119	404	1156	404	119	83
	45	95	141	589	1502	589	141	95
	45	103	150	648	1607	648	150	103
	45	112	160	466	1231	466	160	112

		Width 700 mm						
		105	105	105	70	105	105	105
Height 225 mm	45	75	101	312	905	312	101	75
	45	90	132	446	1234	446	132	90
	45	104	156	624	1564	624	156	104
	45	110	160	657	1623	657	160	110
	45	117	164	482	1267	482	164	117

		Width 700 mm						
		105	105	105	70	105	105	105
Height 225 mm	45	79	109	344	984	344	109	79
	45	96	143	481	1291	481	143	96
	45	110	169	648	1598	648	169	110
	45	115	167	655	1610	655	167	115
	45	121	166	490	1279	490	166	121

		Width 700 mm						
		105	105	105	70	105	105	105
Height 225 mm	45	84	117	376	1064	376	117	84
	45	102	154	515	1348	515	154	102
	45	116	181	672	1632	672	181	116
	45	120	174	652	1597	652	174	120
	45	124	168	497	1292	497	168	124

Support with feather key

		Width 700 mm						
		40	40	40	20	40	40	40
Height 225 mm	45	48	46	63	131	63	46	48
	45	58	58	101	209	101	58	58
	45	66	70	163	287	163	70	66
	45	75	82	196	327	196	82	75
	45	84	94	135	241	135	94	84

		Width 700 mm						
		105	105	105	70	105	105	105
Height 225 mm	45	52	51	80	176	80	51	52
	45	62	65	122	264	122	65	62
	45	71	77	187	352	187	77	71
	45	79	86	215	389	215	86	79
	45	87	95	151	293	151	95	87

		Width 700 mm						
		105	105	105	70	105	105	105
Height 225 mm	45	55	55	99	227	99	55	55
	45	67	71	145	324	145	71	67
	45	76	85	212	421	212	85	76
	45	83	90	233	450	233	90	83
	45	89	96	168	345	168	96	89

		Width 700 mm						
		105	105	105	70	105	105	105
Height 225 mm	45	60	61	122	290	122	61	60
	45	72	79	174	395	174	79	72
	45	83	94	243	500	243	94	83
	45	88	96	256	519	256	96	88
	45	94	99	188	405	188	99	94

		Width 700 mm						
		105	105	105	70	105	105	105
Height 225 mm	45	63	65	145	354	145	65	63
	45	77	86	202	465	202	86	77
	45	88	101	272	575	272	101	88
	45	92	100	275	580	275	100	92
	45	97	100	206	460	206	100	97

		Width 700 mm						
		105	105	105	70	105	105	105
Height 225 mm	45	67	70	169	426	169	70	67
	45	82	93	232	539	232	93	82
	45	93	109	302	653	302	109	93
	45	96	105	293	639	293	105	96
	45	99	101	224	517	224	101	99

AERIAL FCC

2016.25.070./075.

FORCE DIAGRAM

shouldered

		Width 700 mm						
		105	105	105	70	105	105	105
Height 225 mm	45	84	119	390	1092	390	119	84
	45	103	158	525	1341	525	158	103
	45	117	185	664	1591	664	185	117
	45	119	173	620	1511	620	173	119
	45	122	162	482	1245	482	162	122

		Width 700 mm						
		105	105	105	70	105	105	105
Height 225 mm	45	88	125	417	1157	417	125	88
	45	107	167	553	1382	553	167	107
	45	122	195	680	1608	680	195	122
	45	123	178	612	1484	612	178	123
	45	124	162	485	1245	485	162	124

		Width 700 mm						
		105	105	105	70	105	105	105
Height 225 mm	45	90	127	425	1170	425	127	90
	45	110	167	566	1407	566	167	110
	45	125	193	674	1595	674	193	125
	45	123	176	599	1462	599	176	123
	45	121	160	474	1227	474	160	121

		Width 700 mm						
		105	105	105	70	105	105	105
Height 225 mm	45	93	132	441	1206	441	132	93
	45	115	170	590	1460	590	170	115
	45	130	195	681	1614	681	195	130
	45	125	178	599	1467	599	178	125
	45	120	161	472	1232	472	161	120

		Width 700 mm						
		105	105	105	70	105	105	105
Height 225 mm	45	95	133	450	1220	450	133	95
	45	118	170	603	1486	603	170	118
	45	133	193	674	1601	674	193	133
	45	125	176	586	1444	586	176	125
	45	116	159	462	1213	462	159	116

		Width 700 mm						
		105	105	105	70	105	105	105
Height 225 mm	45	97	135	458	1234	458	135	97
	45	121	170	617	1512	617	170	121
	45	136	191	668	1589	668	191	136
	45	125	174	574	1421	574	174	125
	45	113	158	451	1195	451	158	113

Support with feather key

		Width 700 mm						
		105	105	105	70	105	105	105
Height 225 mm	45	67	74	187	480	187	74	67
	45	82	98	252	590	252	98	82
	45	94	114	319	700	319	114	94
	45	96	107	298	665	298	107	96
	45	98	100	231	548	231	100	98

		Width 700 mm						
		105	105	105	70	105	105	105
Height 225 mm	45	70	80	213	555	213	80	70
	45	86	107	282	663	282	107	86
	45	98	125	347	772	347	125	98
	45	98	114	312	712	312	114	98
	45	99	104	247	597	247	104	99

		Width 700 mm						
		105	105	105	70	105	105	105
Height 225 mm	45	72	84	230	609	230	84	72
	45	88	110	305	732	305	110	88
	45	100	127	364	830	364	127	100
	45	98	116	324	760	324	116	98
	45	97	106	256	638	256	106	97

		Width 700 mm						
		105	105	105	70	105	105	105
Height 225 mm	45	75	89	252	676	252	89	75
	45	92	116	336	818	336	116	92
	45	104	132	388	904	388	132	104
	45	100	121	341	822	341	121	100
	45	96	110	269	690	269	110	96

		Width 700 mm						
		105	105	105	70	105	105	105
Height 225 mm	45	76	93	270	732	270	93	76
	45	94	119	362	892	362	119	94
	45	107	135	404	961	404	135	107
	45	100	123	352	866	352	123	100
	45	93	112	277	728	277	112	93

		Width 700 mm						
		105	105	105	70	105	105	105
Height 225 mm	45	78	98	288	790	288	98	78
	45	97	122	388	967	388	122	97
	45	109	138	421	1017	421	138	109
	45	100	126	362	910	362	126	100
	45	90	113	284	764	284	113	90

AERIAL FCC

2016.25.070./075.

FORCE DIAGRAM

shouldered

		Width 700 mm						
		105	105	105	70	105	105	105
Height 225 mm	45	101	140	475	1271	475	140	101
	45	126	173	642	1566	642	173	126
	45	142	193	674	1606	674	193	142
	45	127	176	572	1425	572	176	127
	45	112	159	449	1198	449	159	112

Support with feather key

		Width 700 mm						
		105	105	105	70	105	105	105
Height 225 mm	45	81	104	313	864	313	104	81
	45	101	128	424	1065	424	128	101
	45	113	143	445	1092	445	143	113
	45	101	130	378	969	378	130	101
	45	89	117	296	815	296	117	89

65°

		Width 700 mm						
		105	105	105	70	105	105	105
Height 225 mm	45	105	145	492	1309	492	145	105
	45	132	176	667	1622	667	176	132
	45	147	195	679	1623	679	195	147
	45	129	177	570	1427	570	177	129
	45	110	160	446	1201	446	160	110

65°

		Width 700 mm						
		105	105	105	70	105	105	105
Height 225 mm	45	84	110	339	943	339	110	84
	45	105	134	461	1168	461	134	105
	45	118	148	469	1168	469	148	118
	45	103	135	393	1028	393	135	103
	45	88	121	308	865	308	121	88

70°

		Width 700 mm						
		105	105	105	70	105	105	105
Height 225 mm	45	104	143	487	1287	487	143	104
	45	131	171	663	1604	663	171	131
	45	146	188	654	1566	654	188	146
	45	125	171	542	1365	542	171	125
	45	104	154	423	1150	423	154	104

70°

		Width 700 mm						
		105	105	105	70	105	105	105
Height 225 mm	45	83	111	350	978	350	111	83
	45	105	133	477	1219	477	133	105
	45	117	146	471	1190	471	146	117
	45	100	133	390	1038	390	133	100
	45	83	120	304	874	304	120	83

75°

		Width 700 mm						
		105	105	105	70	105	105	105
Height 225 mm	45	105	143	490	1289	490	143	105
	45	133	169	670	1615	670	169	133
	45	148	184	642	1539	642	184	148
	45	124	167	525	1330	525	167	124
	45	99	150	408	1120	408	150	99

75°

		Width 700 mm						
		105	105	105	70	105	105	105
Height 225 mm	45	84	115	368	1031	368	115	84
	45	106	135	502	1292	502	135	106
	45	118	147	481	1231	481	147	118
	45	99	134	394	1064	394	134	99
	45	80	120	306	896	306	120	80



AERIAL FCC 2016.25.080./085.

Working width: 800/850 mm
Performance class: 1700 kN

AERIAL FCC
2016.25.080./085.
 SIZE TABLE

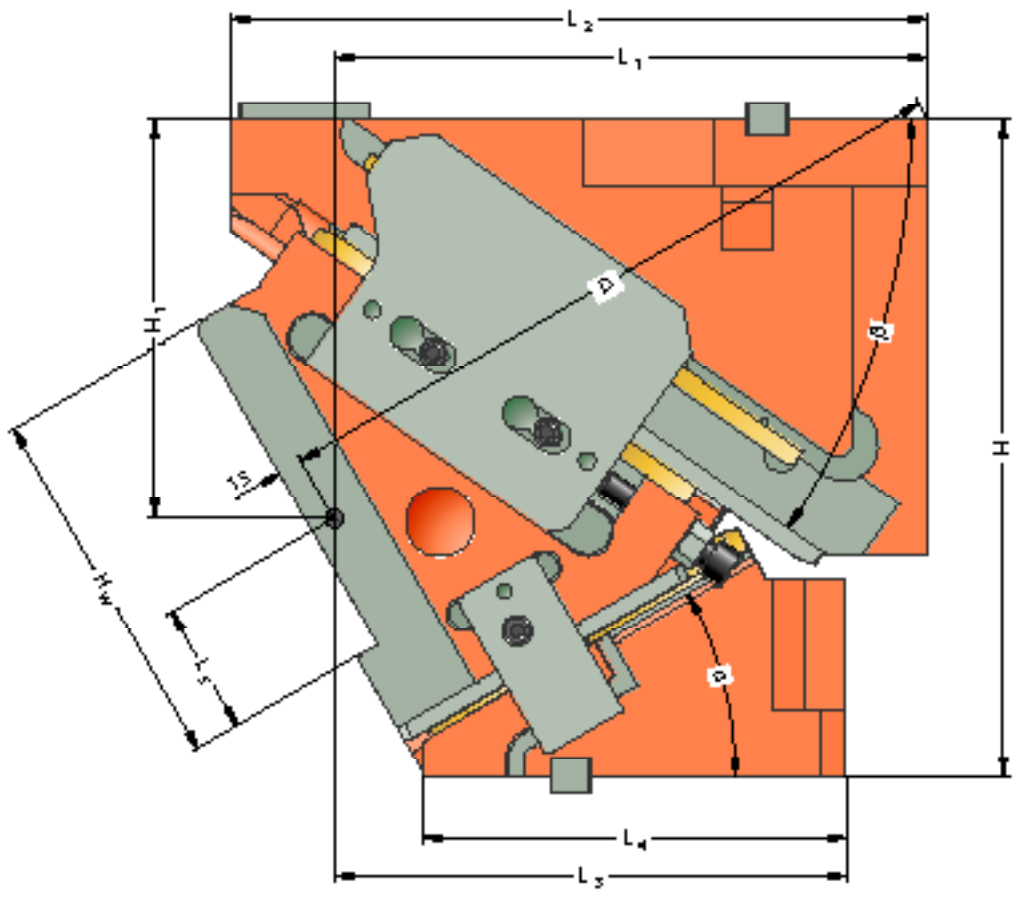
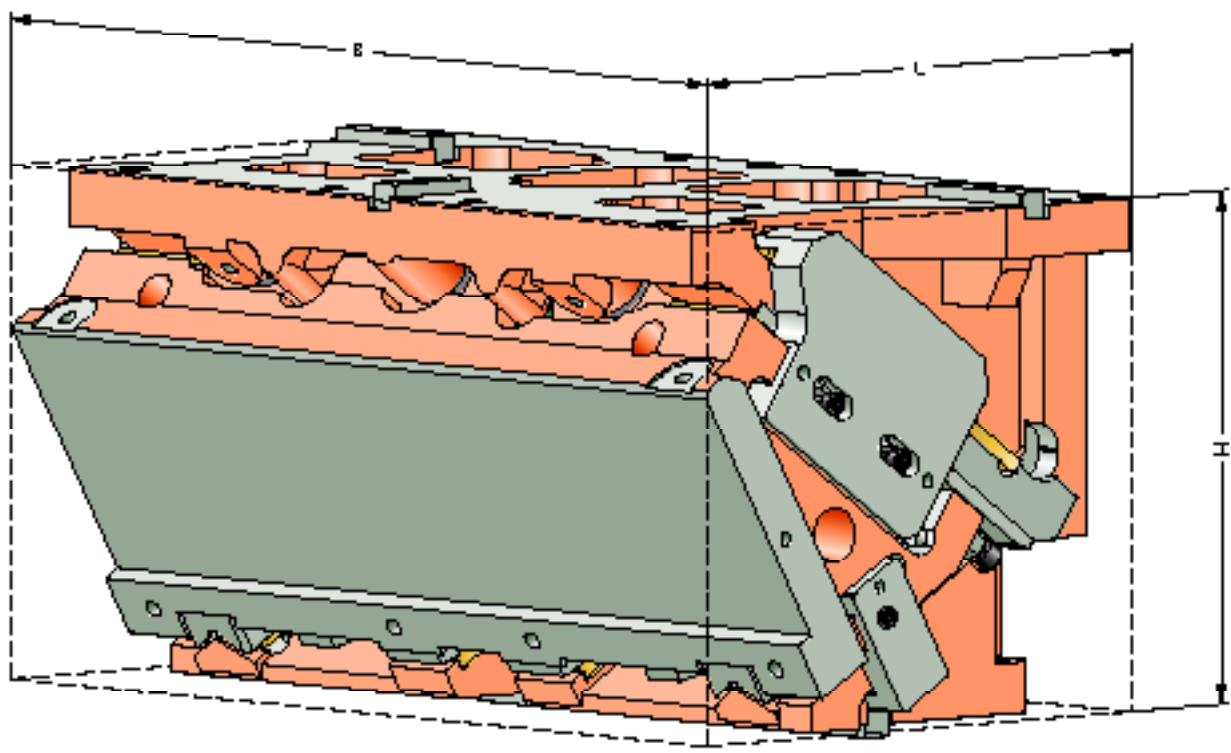

AERIAL FCC

2016.25.080./085.

SIZE TABLE

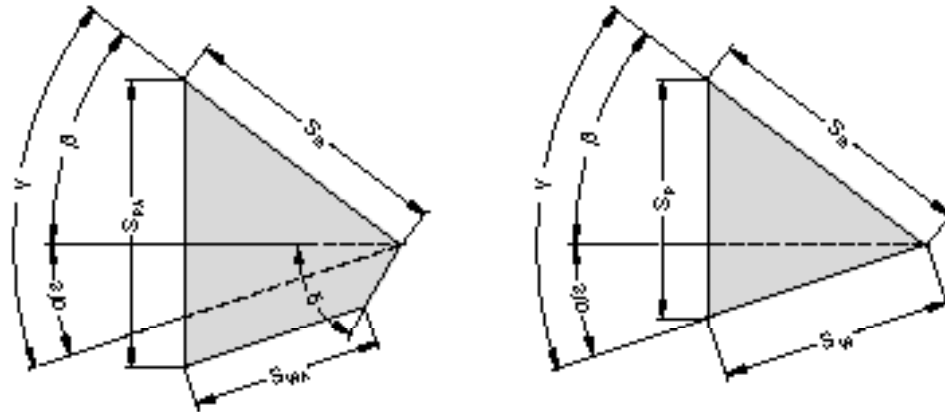

Order No.	L**	B***	H	H ₁	H _W	L ₁	L ₂	L ₃	L ₄	L ₅	D**	α	β	δ	S _W *	S _{WA} *	S _S	S _P *	S _{PA} *
2016.25.8□0.	[mm]	[mm]	[mm]	[mm]	[mm]	[mm]	[mm]	[mm]	[mm]	[mm]	[mm]	[°]	[°]	[°]	[mm]	[mm]	[mm]	[mm]	[mm]
00.□000.02	395	8□0	400	208	220	365	370	280	305	80	395	0	50	45	-	45.7	100	-	95.2
05.□000.02	409.1	8□0	400	209	220	367.03	385	297.03	308	80	413.84	5	45	50	-	53.8	100	-	95.8
10.□000.02	428	8□0	400	208.61	220	374.12	385	304.12	302	80	434.66	10	45	45	-	56.6	100	-	95.5
15.□000.02	441.4	8□0	400	218.84	220	376.22	405	316.22	300	80	450.04	15	40	50	-	65.5	100	-	97.2
20.□000.02	449.3	8□0	400	229.69	220	373.27	410	298.27	270	80	459.32	20	40	45	-	68.8	100	-	99.8
25.□000.02	456.6	8□0	400	236.16	220	370.22	420	305.22	263	80	465.33	25	35	50	-	74.3	95	-	98.4
30.□000.02	458	8□0	400	243.22	220	362.01	425	312.01	258	80	465.12	30	35	45	-	79.5	95	-	103.2
35.□000.02	458.5	8□0	400	250.86	220	353.6	440	318.6	253	80	463.54	35	30	50	-	81.4	85	-	97.5
40.□000.02	462.9	8□0	400	259.08	220	349.93	450	324.93	247	80	464.59	40	25	55	-	93.0	85	-	104.0
45.□000.02	461.2	8□0	400	262.83	220	340.96	455	330.96	243	80	456.94	45	20	60	-	100.2	80	-	105.7
50.□000.02	483.2	8□0	400	267.09	220	356.64	480	336.64	264	80	463.85	50	10	-	107.2	-	70	94.3	-
55.□000.02	475.1	8□0	400	271.83	220	331.93	460	341.93	260	80	443.05	55	10	-	103.0	-	60	94.8	-
60.□000.02	480	8□0	400	277.01	220	316.78	470	326.78	237	80	428.29	60	10	-	108.3	-	55	103.4	-
65.□000.02	490	8□0	400	282.6	220	281.17	440	331.17	234	80	404.94	65	0	-	106.5	-	45	96.5	-
70.□000.02	505	8□0	400	288.54	220	265.05	435	335.05	232	80	391.79	70	0	-	117.0	-	40	109.9	-
75.□000.02	515	8□0	400	294.81	220	248.39	425	338.39	230	80	379.05	75	0	-	115.9	-	30	112.0	-

* Values rounded

** Values L, D measured for option with shouldered working surface

*** 8□0 = 800 or 850 mm

Mounting cam base:

Hexagon socket head cap screws DIN EN ISO 4762

8x M20 / Strength class min. 8.8

Dowel pins DIN EN ISO 8735

2x ø16

Mounting cam driver:

Hexagon socket head cap screws DIN EN ISO 4762

2x4 M16 / Strength class min. 8.8

Dowel pins DIN EN ISO 8735

2x2 ø12

AERIAL FCC
2016.25.080./085.
 EXPLODED VIEW

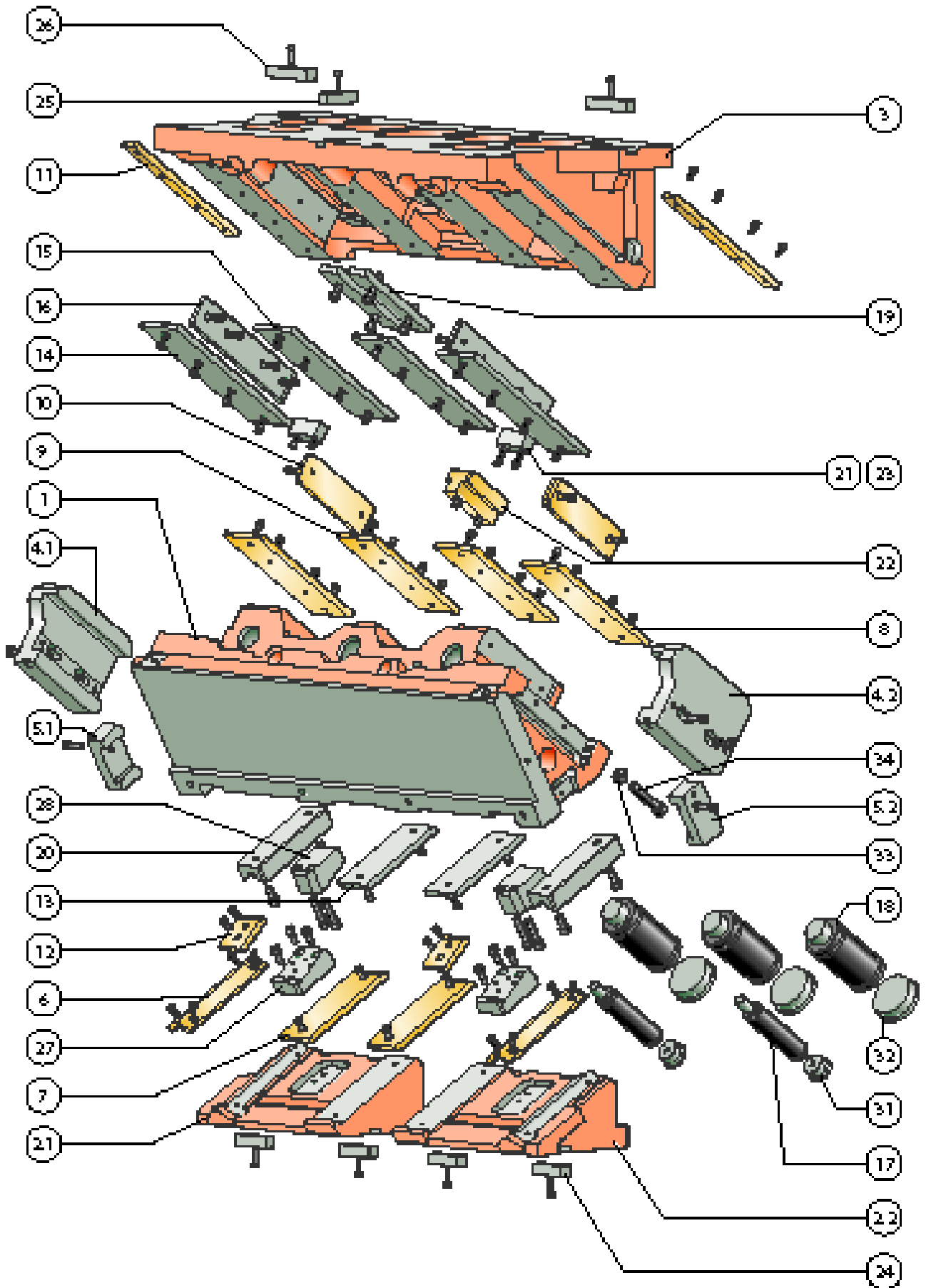

AERIAL FCC

2016.25.080./085.

PARTS LIST

Position	Piece	Designation	Material	spare part
1	1	Slider		
2.1	1	Driver, left		
2.2	1	Driver, right		
3	1	Slider cam base		
4.1	1	Clamp, left		x
4.2	1	Clamp, right		x
5.1	1	Positive return, left		x
5.2	1	Positive return, right		x
6	4	Sliding plate VDI	Bronze with solid lubricant	x
7	2	Sliding plate VDI	Bronze with solid lubricant	x
8	2	Sliding plate VDI	Bronze with solid lubricant	x
9	2	Sliding plate VDI	Bronze with solid lubricant	x
10	2	Sliding plate VDI	Bronze with solid lubricant	x
11	2	Sliding plate VDI	Bronze with solid lubricant	x
12**	2	Sliding plate VDI	Bronze with solid lubricant	x
13	2	Sliding plate VDI	Steel	x
14	2	Sliding plate VDI	Steel	x
15	2	Sliding plate VDI	Steel	x
16	2	Sliding plate VDI	Steel	x
17	2	Gas spring	2487.12.00500.125	x
18	3	Gas spring	2487.12.02400.□□□	x
19	2	Cover strip		x
20	2	Prismatic guide		x
21	2	Stop plate		x
22	1	Centre guide		x
23	2	Damper		x
24	4	Feather key (T-nut)		x
25	1	Feather key (T-nut)		x
26	2	Feather key (T-nut)		x
27**	2	Construction piece		x
28**	2	Slide pad		x
29* (not shown)	2	Curve wedge		x
30* (not shown)	2	Roller block		x
31	2	Locking screw		x
32	3	Locking screw		x
33	2	Ball-head screw		x
34	2	Hexagon nut		x

up to and including 45° with pre-acceleration

Optionally:

* Roll pre-acceleration (.1000. /.2000.)

** Plate pre-acceleration (.3000. /.4000.)

For inquiries or when ordering spare parts (x), we require the following data:

- Cam unit order no.
- Cam unit serial number
- Item number / Designation / Spare part

AERIAL FCC

2016.25.080./085.

SYSTEM AND SURROUNDING FORCES

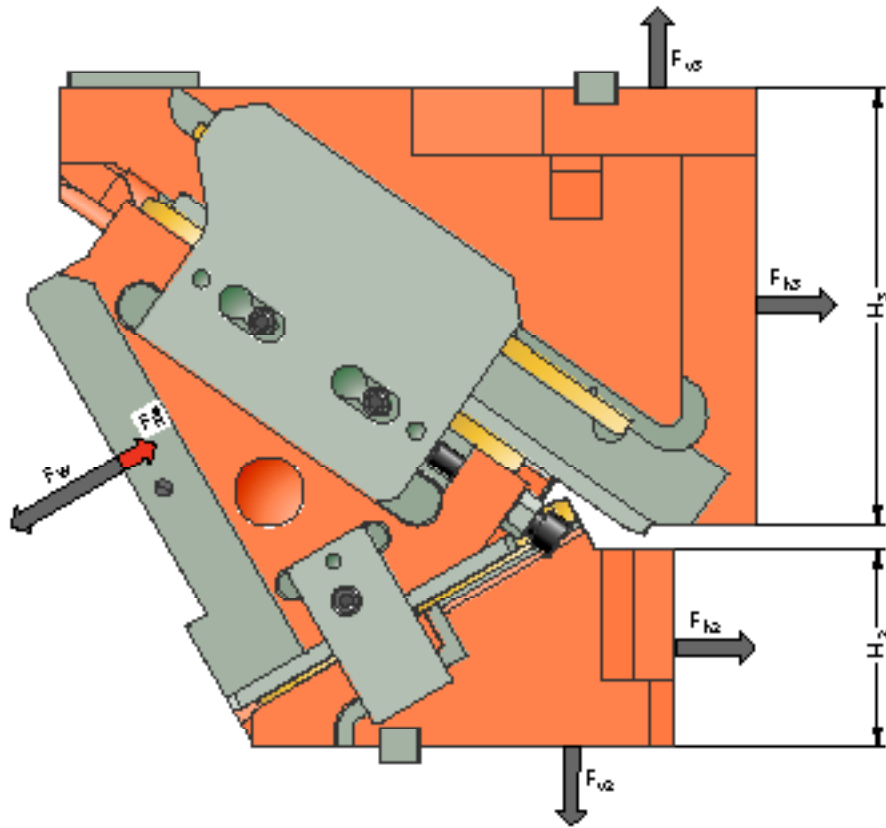

Order number	α [°]	F_W [kN]	F_R^* [kN]	F_{h2} [kN]	F_{v2} [kN]	F_{h3} [kN]	F_{v3} [kN]	H_2 [mm]	H_3 [mm]
2016.25.08□.02.□000.02	0	1700	149.3	0	1426	1700	1426	40	300
2016.25.08□.05.□000.02	5	1700	152.3	124	1421	1569	1569	40	275
2016.25.08□.10.□000.02	10	1700	169.6	207	1172	1467	1467	75	275
2016.25.08□.15.□000.02	15	1700	172.3	308	1150	1334	1590	80	255
2016.25.08□.20.□000.02	20	1700	195.1	407	1119	1190	1700	90	245
2016.25.08□.25.□000.02	25	1700	193.9	415	890	1126	1608	110	215
2016.25.08□.30.□000.02	30	1700	225.1	396	687	1076	1537	120	210
2016.25.08□.35.□000.02	35	1700	219.4	455	649	938	1624	140	210
2016.25.08□.40.□000.02	40	1700	221.1	510	607	793	1700	150	190
2016.25.08□.45.□000.02	45	1700	218.6	561	561	642	1763	170	170
2016.25.08□.50.□000.02	50	1700	186.1	752	631	341	1933	170	120
2016.25.08□.55.□000.02	55	1700	206.6	649	455	326	1847	180	115
2016.25.08□.60.□000.02	60	1700	256.5	536	309	314	1782	180	110
2016.25.08□.65.□000.02	65	1700	204.3	718	335	0	1876	190	85
2016.25.08□.70.□000.02	70	1700	246.0	581	212	0	1809	205	85
2016.25.08□.75.□000.02	75	1700	289.9	440	118	0	1760	220	85

* Retraction force values correspond to the spring-generated retraction force at the working point point

The forces F_{h2} , F_{v2} as well as F_{h3} , F_{v3} act on the tool environment at maximum working force F_W .

AERIAL FCC

2016.25.080./085.

FORCE DIAGRAM

shouldered

		Width 800 mm						
		120	120	120	80	120	120	120
Height 225 mm	45	76	113	335	869	335	113	76
	45	94	145	491	1310	491	145	94
	45	108	169	689	1680	689	169	108
	45	114	169	703	1705	703	169	114
	45	120	169	504	1306	504	169	120

		Width 800 mm						
		120	120	120	80	120	120	120
Height 225 mm	45	79	118	354	926	354	118	79
	45	97	152	512	1345	512	152	97
	45	112	178	705	1703	705	178	112
	45	117	175	705	1704	705	175	117
	45	123	172	514	1322	514	172	123

		Width 800 mm						
		120	120	120	80	120	120	120
Height 225 mm	45	81	123	374	984	374	123	81
	45	100	160	533	1380	533	160	100
	45	116	186	721	1725	721	186	116
	45	121	180	708	1703	708	180	121
	45	126	174	524	1339	524	174	126

		Width 800 mm						
		120	120	120	80	120	120	120
Height 225 mm	45	82	126	387	1022	387	126	82
	45	102	165	545	1389	545	165	102
	45	117	191	723	1715	723	191	117
	45	122	182	698	1671	698	182	122
	45	126	173	524	1331	524	173	126

		Width 800 mm						
		120	120	120	80	120	120	120
Height 225 mm	45	84	130	402	1069	402	130	84
	45	104	170	561	1410	561	170	104
	45	120	198	732	1721	732	198	120
	45	124	186	694	1655	694	186	124
	45	128	174	529	1334	529	174	128

		Width 800 mm						
		120	120	120	80	120	120	120
Height 225 mm	45	87	136	425	1135	425	136	87
	45	108	179	587	1457	587	179	108
	45	125	208	754	1759	754	208	125
	45	128	193	703	1670	703	193	128
	45	132	178	543	1363	543	178	132

Support with feather key

		Width 800 mm						
		120	120	120	80	120	120	120
Height 225 mm	45	61	68	100	174	100	68	61
	45	75	87	147	262	147	87	75
	45	87	101	207	336	207	101	87
	45	91	101	211	341	211	101	91
	45	96	102	151	261	151	102	96

		Width 800 mm						
		120	120	120	80	120	120	120
Height 225 mm	45	63	71	117	222	117	71	63
	45	78	91	169	323	169	91	78
	45	90	107	233	409	233	107	90
	45	94	105	233	409	233	105	94
	45	98	103	170	317	170	103	98

		Width 800 mm						
		120	120	120	80	120	120	120
Height 225 mm	45	65	74	135	275	135	74	65
	45	80	96	192	386	192	96	80
	45	93	112	259	483	259	112	93
	45	97	108	255	477	255	108	97
	45	101	104	189	375	189	104	101

		Width 800 mm						
		120	120	120	80	120	120	120
Height 225 mm	45	66	75	151	327	151	75	66
	45	82	99	212	444	212	99	82
	45	94	115	282	549	282	115	94
	45	97	109	272	535	272	109	97
	45	101	104	204	426	204	104	101

		Width 800 mm						
		120	120	120	80	120	120	120
Height 225 mm	45	67	78	169	385	169	78	67
	45	83	102	235	508	235	102	83
	45	96	119	307	620	307	119	96
	45	99	112	291	596	291	112	99
	45	102	104	222	480	222	104	102

		Width 800 mm						
		120	120	120	80	120	120	120
Height 225 mm	45	70	81	191	454	191	81	70
	45	87	108	264	583	264	108	87
	45	100	125	339	704	339	125	100
	45	103	116	316	668	316	116	103
	45	106	107	244	545	244	107	106

AERIAL FCC

2016.25.080./085.

FORCE DIAGRAM

shouldered

		Width 800 mm						
		120	120	120	80	120	120	120
Height 225 mm	45	90	141	445	1191	445	141	90
	45	112	187	608	1491	608	187	112
	45	128	217	769	1781	769	217	128
	45	132	198	705	1669	705	198	132
	45	135	180	553	1379	553	180	135

		Width 800 mm						
		120	120	120	80	120	120	120
Height 225 mm	45	87	138	438	1178	438	138	87
	45	108	183	594	1440	594	183	108
	45	125	213	741	1702	741	213	125
	45	128	192	669	1575	669	192	128
	45	130	172	531	1318	531	172	130

		Width 800 mm						
		120	120	120	80	120	120	120
Height 225 mm	45	90	139	451	1202	451	139	90
	45	112	184	608	1467	608	184	112
	45	129	212	738	1695	738	212	129
	45	128	191	658	1556	658	191	128
	45	127	170	522	1303	522	170	127

		Width 800 mm						
		120	120	120	80	120	120	120
Height 225 mm	45	93	142	469	1238	469	142	93
	45	117	186	629	1509	629	186	117
	45	134	214	742	1705	742	214	134
	45	130	191	655	1552	655	191	130
	45	125	169	518	1300	518	169	125

		Width 800 mm						
		120	120	120	80	120	120	120
Height 225 mm	45	96	144	486	1274	486	144	96
	45	122	188	649	1551	649	188	122
	45	139	215	746	1714	746	215	139
	45	131	191	650	1547	650	191	131
	45	124	167	513	1298	513	167	124

		Width 800 mm						
		120	120	120	80	120	120	120
Height 225 mm	45	99	147	504	1311	504	147	99
	45	127	191	670	1594	670	191	127
	45	144	217	750	1723	750	217	144
	45	133	192	646	1542	646	192	133
	45	122	166	509	1295	509	166	122

Support with feather key

		Width 800 mm						
		120	120	120	80	120	120	120
Height 225 mm	45	72	87	213	524	213	87	72
	45	89	116	292	656	292	116	89
	45	103	134	369	784	369	134	103
	45	105	123	339	734	339	123	105
	45	108	112	265	607	265	112	108

		Width 800 mm						
		120	120	120	80	120	120	120
Height 225 mm	45	70	88	224	566	224	88	70
	45	87	117	303	691	303	117	87
	45	100	136	378	817	378	136	100
	45	102	123	341	756	341	123	102
	45	104	110	271	633	271	110	104

		Width 800 mm						
		120	120	120	80	120	120	120
Height 225 mm	45	72	92	244	625	244	92	72
	45	90	121	328	763	328	121	90
	45	103	140	399	882	399	140	103
	45	102	126	356	809	356	126	102
	45	102	112	282	677	282	112	102

		Width 800 mm						
		120	120	120	80	120	120	120
Height 225 mm	45	74	96	267	693	267	96	74
	45	94	127	358	845	358	127	94
	45	107	145	423	955	423	145	107
	45	104	130	373	869	373	130	104
	45	100	115	295	728	295	115	100

		Width 800 mm						
		120	120	120	80	120	120	120
Height 225 mm	45	77	101	292	765	292	101	77
	45	97	132	390	931	390	132	97
	45	111	151	448	1028	448	151	111
	45	105	134	390	928	390	134	105
	45	99	117	308	779	308	117	99

		Width 800 mm						
		120	120	120	80	120	120	120
Height 225 mm	45	80	106	318	839	318	106	80
	45	101	137	422	1020	422	137	101
	45	116	156	473	1103	473	156	116
	45	106	138	407	987	407	138	106
	45	97	120	321	829	321	120	97

AERIAL FCC

2016.25.080./085.

FORCE DIAGRAM

shouldered

		Width 800 mm						
		120	120	120	80	120	120	120
Height 225 mm	45	102	148	517	1335	517	148	102
	45	131	191	685	1622	685	191	131
	45	148	217	747	1716	747	217	148
	45	133	190	636	1523	636	190	133
	45	118	163	499	1279	499	163	118

Support with feather key

		Width 800 mm						
		120	120	120	80	120	120	120
Height 225 mm	45	81	110	341	908	341	110	81
	45	104	141	452	1103	452	141	104
	45	119	160	493	1167	493	160	119
	45	107	141	420	1035	420	141	107
	45	95	121	330	870	330	121	95

65°

		Width 800 mm						
		120	120	120	80	120	120	120
Height 225 mm	45	103	148	526	1347	526	148	103
	45	133	190	693	1634	693	190	133
	45	151	214	737	1692	737	214	151
	45	133	187	619	1488	619	187	133
	45	114	159	485	1252	485	159	114

65°

		Width 800 mm						
		120	120	120	80	120	120	120
Height 225 mm	45	83	113	363	970	363	113	83
	45	107	144	478	1176	478	144	107
	45	121	163	508	1218	508	163	121
	45	106	142	427	1072	427	142	106
	45	91	121	335	901	335	121	91

70°

		Width 800 mm						
		120	120	120	80	120	120	120
Height 225 mm	45	106	149	539	1371	539	149	106
	45	137	190	708	1661	708	190	137
	45	155	214	734	1685	734	214	155
	45	133	185	609	1469	609	185	133
	45	111	156	476	1237	476	156	111

70°

		Width 800 mm						
		120	120	120	80	120	120	120
Height 225 mm	45	84	117	388	1042	388	117	84
	45	110	148	510	1263	510	148	110
	45	124	167	528	1280	528	167	124
	45	106	144	438	1116	438	144	106
	45	89	122	342	940	342	122	89

75°

		Width 800 mm						
		120	120	120	80	120	120	120
Height 225 mm	45	109	152	557	1409	557	152	109
	45	142	193	730	1705	730	193	142
	45	160	215	737	1693	737	215	160
	45	135	185	604	1463	604	185	135
	45	109	155	471	1233	471	155	109

75°

		Width 800 mm						
		120	120	120	80	120	120	120
Height 225 mm	45	87	122	418	1127	418	122	87
	45	114	154	547	1364	547	154	114
	45	128	172	553	1355	553	172	128
	45	108	148	453	1171	453	148	108
	45	87	124	353	987	353	124	87



AERIAL FCC **2016.25.090./095.**

Working width: 900/950 mm
Performance class: 1800 kN

AERIAL FCC
2016.25.090./095.
 SIZE TABLE

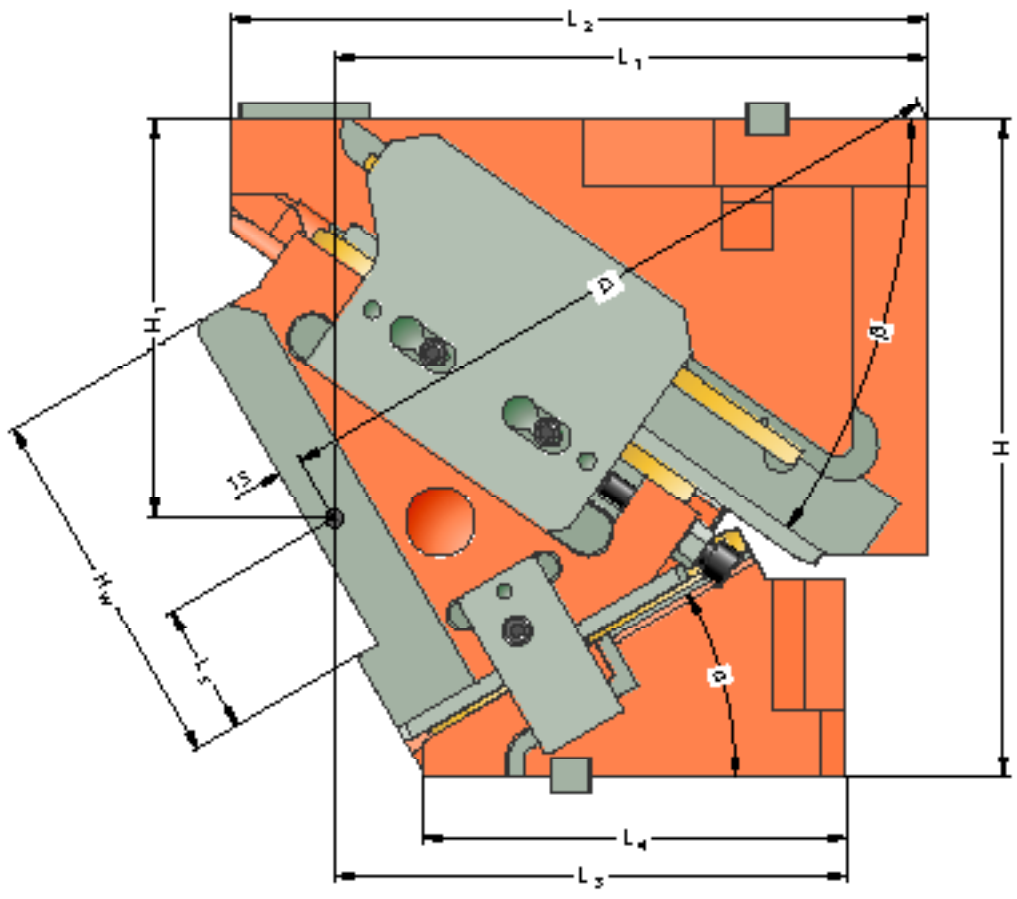
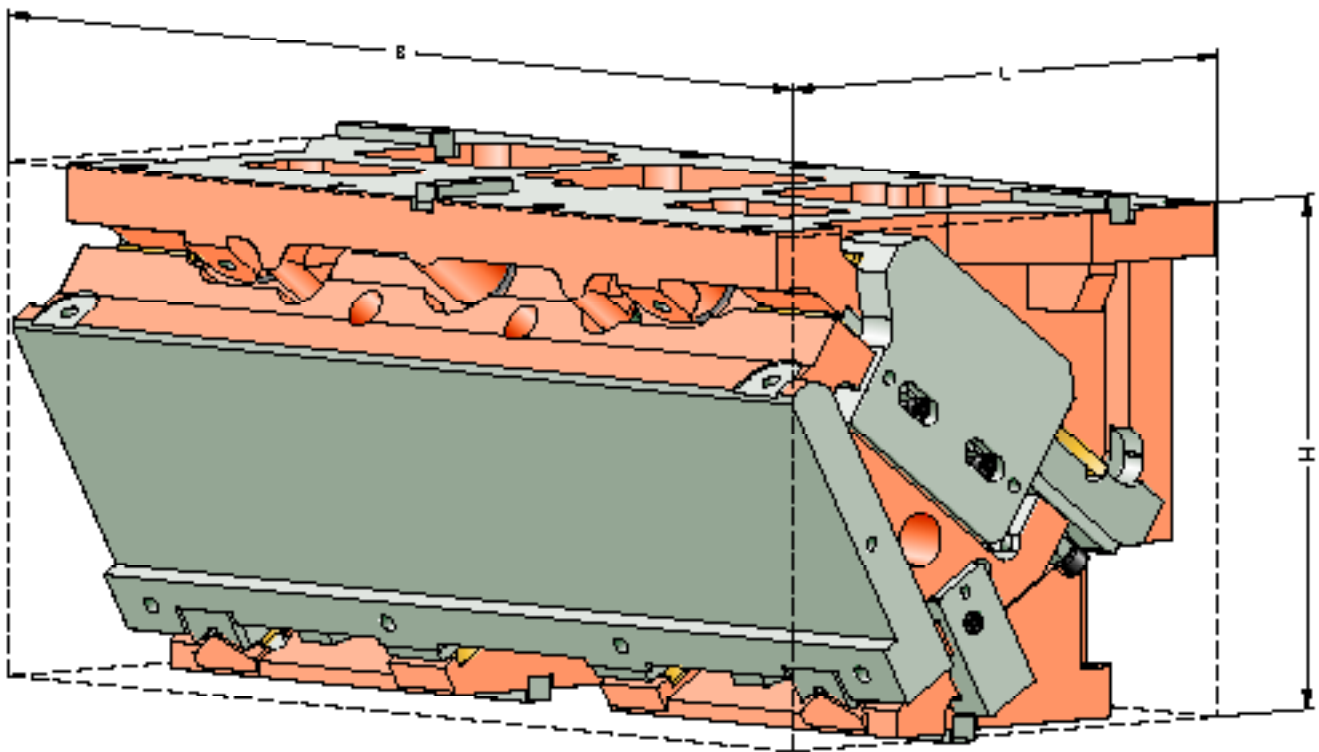

AERIAL FCC

2016.25.090./095.

SIZE TABLE

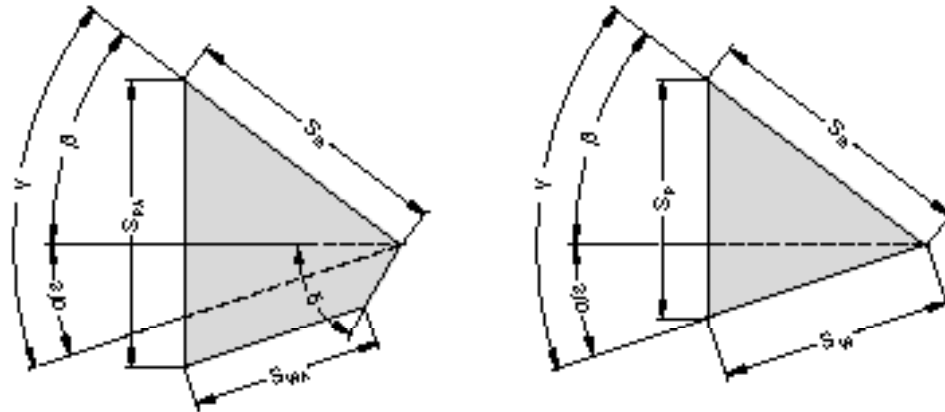

Order No.	L**	B***	H	H ₁	H _w	L ₁	L ₂	L ₃	L ₄	L ₅	D**	α	β	δ	S _w *	S _{wa} *	S _s	S _p *	S _{pa} *
2016.25.09□.	[mm]	[mm]	[mm]	[mm]	[mm]	[mm]	[mm]	[mm]	[mm]	[mm]	[mm]	[°]	[°]	[°]	[mm]	[mm]	[mm]	[mm]	[mm]
00.□000.02	395	9□0	400	208	220	365	370	280	305	80	395	0	50	45	-	45.7	100	-	95.2
05.□000.02	409.1	9□0	400	209	220	367.03	385	297.03	308	80	413.84	5	45	50	-	53.8	100	-	95.8
10.□000.02	428	9□0	400	208.61	220	374.12	385	304.12	302	80	434.66	10	45	45	-	56.6	100	-	95.5
15.□000.02	441.4	9□0	400	218.84	220	376.22	405	316.22	300	80	450.04	15	40	50	-	65.5	100	-	97.2
20.□000.02	449.3	9□0	400	229.69	220	373.27	410	298.27	270	80	459.32	20	40	45	-	68.8	100	-	99.8
25.□000.02	456.6	9□0	400	236.16	220	370.22	420	305.22	263	80	465.33	25	35	50	-	74.3	95	-	98.4
30.□000.02	458	9□0	400	243.22	220	362.01	425	312.01	258	80	465.12	30	35	45	-	79.5	95	-	103.2
35.□000.02	458.5	9□0	400	250.86	220	353.6	440	318.6	253	80	463.54	35	30	50	-	81.4	85	-	97.5
40.□000.02	462.9	9□0	400	259.08	220	349.93	450	324.93	247	80	464.59	40	25	55	-	93.0	85	-	104.0
45.□000.02	461.2	9□0	400	262.83	220	340.96	455	330.96	243	80	456.94	45	20	60	-	100.2	80	-	105.7
50.□000.02	483.2	9□0	400	267.09	220	356.64	480	336.64	264	80	463.85	50	10	-	107.2	-	70	94.3	-
55.□000.02	475.1	9□0	400	271.83	220	331.93	460	341.93	260	80	443.05	55	10	-	103.0	-	60	94.8	-
60.□000.02	480	9□0	400	277.01	220	316.78	470	326.78	237	80	428.29	60	10	-	108.3	-	55	103.4	-
65.□000.02	490	9□0	400	282.6	220	281.17	440	331.17	234	80	404.94	65	0	-	106.5	-	45	96.5	-
70.□000.02	505	9□0	400	288.54	220	265.05	435	335.05	232	80	391.79	70	0	-	117.0	-	40	109.9	-
75.□000.02	515	9□0	400	294.81	220	248.39	425	338.39	230	80	379.05	75	0	-	115.9	-	30	112.0	-

* Values rounded

** Values L, D measured for option with shouldered working surface

*** 9□0 = 900 or 950 mm

Mounting cam base:

Hexagon socket head cap screws DIN EN ISO 4762

8x M20 / Strength class min. 8.8

Dowel pins DIN EN ISO 8735

2x ø16

Mounting cam driver:

Hexagon socket head cap screws DIN EN ISO 4762

2x4 M16 / Strength class min. 8.8

Dowel pins DIN EN ISO 8735

2x2 ø12

AERIAL FCC
2016.25.090./095.
 EXPLODED VIEW

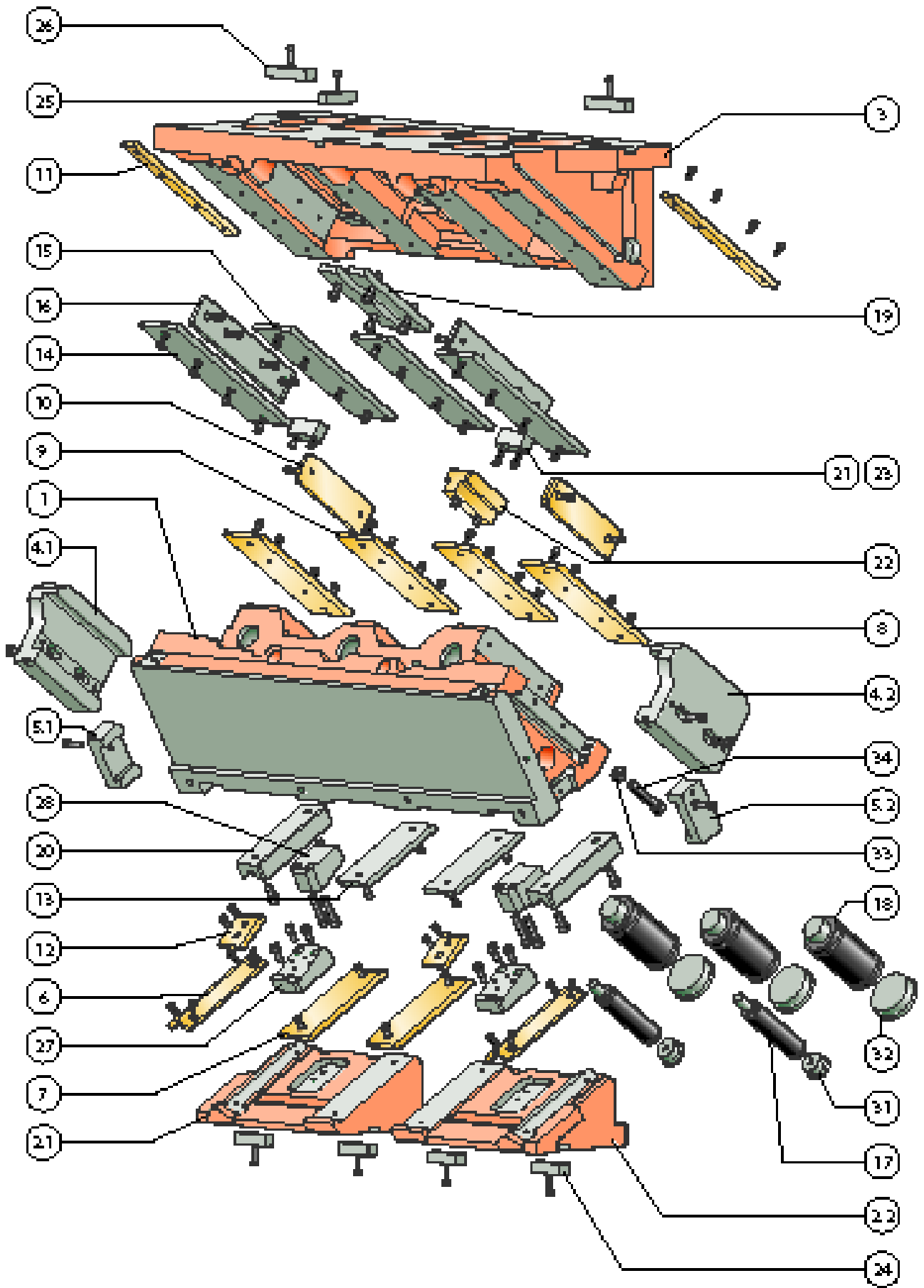

AERIAL FCC

2016.25.090./095.

PARTS LIST

Position	Piece	Designation	Material	spare part
1	1	Slider		
2.1	1	Driver, left		
2.2	1	Driver, right		
3	1	Slider cam base		
4.1	1	Clamp, left		x
4.2	1	Clamp, right		x
5.1	1	Positive return, left		x
5.2	1	Positive return, right		x
6	4	Sliding plate VDI	Bronze with solid lubricant	x
7	2	Sliding plate VDI	Bronze with solid lubricant	x
8	2	Sliding plate VDI	Bronze with solid lubricant	x
9	2	Sliding plate VDI	Bronze with solid lubricant	x
10	2	Sliding plate VDI	Bronze with solid lubricant	x
11	2	Sliding plate VDI	Bronze with solid lubricant	x
12**	2	Sliding plate VDI	Bronze with solid lubricant	x
13	2	Sliding plate VDI	Steel	x
14	2	Sliding plate VDI	Steel	x
15	2	Sliding plate VDI	Steel	x
16	2	Sliding plate VDI	Steel	x
17	2	Gas spring	2487.12.00500.125	x
18	3	Gas spring	2487.12.02400.□□□	x
19	2	Cover strip		x
20	2	Prismatic guide		x
21	2	Stop plate		x
22	1	Centre guide		x
23	2	Damper		x
24	4	Feather key (T-nut)		x
25	1	Feather key (T-nut)		x
26	2	Feather key (T-nut)		x
27**	2	Construction piece		x
28**	2	Slide pad		x
29* (not shown)	2	Curve wedge		x
30* (not shown)	2	Roller block		x
31	2	Locking screw		x
32	3	Locking screw		x
33	2	Ball-head screw		x
34	2	Hexagon nut		x

up to and including 45° with pre-acceleration

Optionally:

* Roll pre-acceleration (.1000. /.2000.)

** Plate pre-acceleration (.3000. /.4000.)

For inquiries or when ordering spare parts (x), we require the following data:

- Cam unit order no.
- Cam unit serial number
- Item number / Designation / Spare part

AERIAL FCC

2016.25.090./095.

SYSTEM AND SURROUNDING FORCES

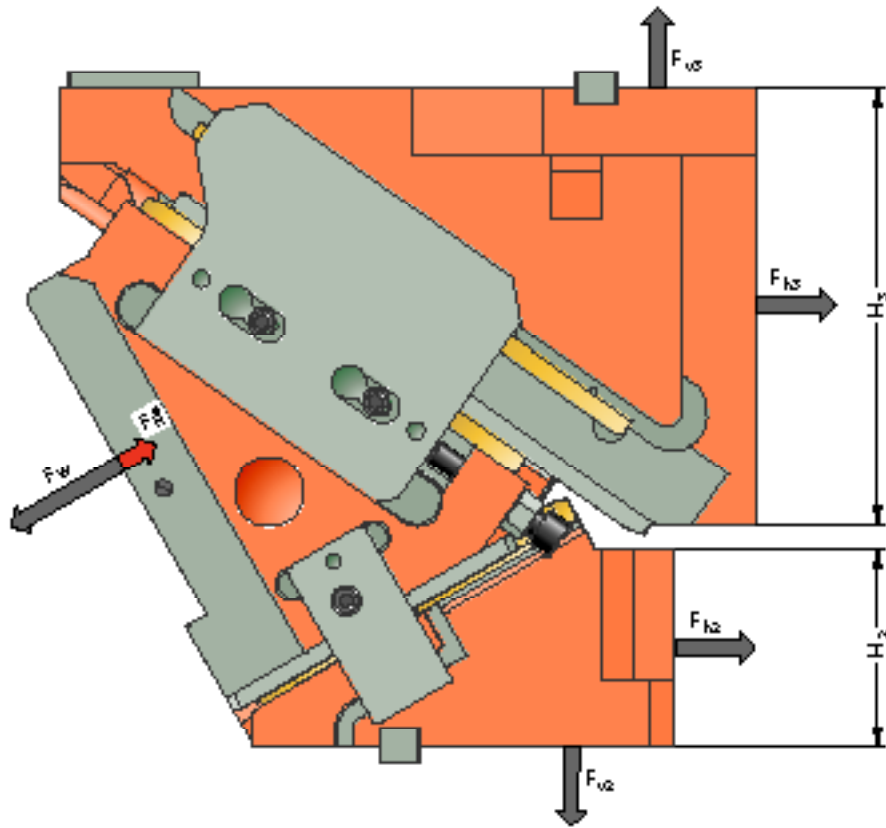

Order number	α [°]	F_W [kN]	F_R^* [kN]	F_{h2} [kN]	F_{v2} [kN]	F_{h3} [kN]	F_{v3} [kN]	H_2 [mm]	H_3 [mm]
2016.25.09□.00.□000.02	0	1800	149.3	0	1510	1800	1510	40	300
2016.25.09□.05.□000.02	5	1800	152.3	132	1505	1662	1662	40	275
2016.25.09□.10.□000.02	10	1800	169.6	219	1241	1554	1554	75	275
2016.25.09□.15.□000.02	15	1800	172.3	326	1217	1412	1683	80	255
2016.25.09□.20.□000.02	20	1800	195.1	431	1184	1260	1800	90	245
2016.25.09□.25.□000.02	25	1800	193.9	439	942	1192	1703	110	215
2016.25.09□.30.□000.02	30	1800	225.1	420	727	1139	1627	120	210
2016.25.09□.35.□000.02	35	1800	219.4	481	688	993	1720	140	210
2016.25.09□.40.□000.02	40	1800	221.1	540	643	839	1800	150	190
2016.25.09□.45.□000.02	45	1800	218.6	594	594	679	1866	170	170
2016.25.09□.50.□000.02	50	1800	186.1	796	668	361	2047	170	120
2016.25.09□.55.□000.02	55	1800	206.6	688	481	345	1956	180	115
2016.25.09□.60.□000.02	60	1800	256.5	567	328	333	1886	180	110
2016.25.09□.65.□000.02	65	1800	204.3	761	355	0	1986	190	85
2016.25.09□.70.□000.02	70	1800	246.0	616	224	0	1916	205	85
2016.25.09□.75.□000.02	75	1800	289.9	466	125	0	1863	220	85

* Retraction force values correspond to the spring-generated retraction force at the working point point

The forces F_{h2} , F_{v2} as well as F_{h3} , F_{v3} act on the tool environment at maximum working force F_W .

AERIAL FCC

2016.25.090./095.

FORCE DIAGRAM

shouldered

		Width 900 mm						
		135	135	135	90	135	135	135
Height 225 mm	45	87	141	434	1023	434	141	87
	45	109	183	610	1486	610	183	109
	45	126	209	788	1813	788	209	126
	45	126	190	707	1667	707	190	126
	45	126	171	524	1320	524	171	126

		Width 900 mm						
		135	135	135	90	135	135	135
Height 225 mm	45	87	143	441	1057	441	143	87
	45	110	186	618	1498	618	186	110
	45	127	214	795	1823	795	214	127
	45	128	194	714	1678	714	194	128
	45	129	174	536	1339	536	174	129

		Width 900 mm						
		135	135	135	90	135	135	135
Height 225 mm	45	87	144	443	1080	443	144	87
	45	110	188	620	1496	620	188	110
	45	127	216	795	1815	795	216	127
	45	128	196	715	1673	715	196	128
	45	130	175	542	1346	542	175	130

		Width 900 mm						
		135	135	135	90	135	135	135
Height 225 mm	45	88	146	450	1113	450	146	88
	45	111	192	627	1508	627	192	111
	45	128	221	802	1825	802	221	128
	45	130	199	722	1684	722	199	130
	45	132	178	553	1365	553	178	132

		Width 900 mm						
		135	135	135	90	135	135	135
Height 225 mm	45	88	147	452	1136	452	147	88
	45	110	194	629	1505	629	194	110
	45	128	223	802	1817	802	223	128
	45	131	201	723	1679	723	201	131
	45	133	179	559	1371	559	179	133

		Width 900 mm						
		135	135	135	90	135	135	135
Height 225 mm	45	87	148	454	1157	454	148	87
	45	110	196	630	1502	630	196	110
	45	128	225	801	1809	801	225	128
	45	131	203	723	1673	723	203	131
	45	135	180	565	1377	565	180	135

Support with feather key

		Width 900 mm						
		135	135	135	90	135	135	135
Height 225 mm	45	69	84	130	205	130	84	69
	45	88	110	183	297	183	110	88
	45	101	126	236	363	236	126	101
	45	101	114	212	333	212	114	101
	45	101	103	157	264	157	103	101

		Width 900 mm						
		135	135	135	90	135	135	135
Height 225 mm	45	70	86	145	254	145	86	70
	45	88	112	204	360	204	112	88
	45	102	128	262	437	262	128	102
	45	102	116	236	403	236	116	102
	45	103	104	177	321	177	104	103

		Width 900 mm						
		135	135	135	90	135	135	135
Height 225 mm	45	70	86	160	302	160	86	70
	45	88	113	223	419	223	113	88
	45	102	130	286	508	286	130	102
	45	103	117	257	468	257	117	103
	45	104	105	195	377	195	105	104

		Width 900 mm						
		135	135	135	90	135	135	135
Height 225 mm	45	70	88	175	356	175	88	70
	45	89	115	245	482	245	115	89
	45	103	133	313	584	313	133	103
	45	104	120	282	539	282	120	104
	45	106	107	216	437	216	107	106

		Width 900 mm						
		135	135	135	90	135	135	135
Height 225 mm	45	70	88	190	409	190	88	70
	45	88	116	264	542	264	116	88
	45	102	134	337	654	337	134	102
	45	105	121	304	604	304	121	105
	45	107	107	235	494	235	107	107

		Width 900 mm						
		135	135	135	90	135	135	135
Height 225 mm	45	70	89	204	463	204	89	70
	45	88	117	284	601	284	117	88
	45	102	135	360	724	360	135	102
	45	105	122	325	669	325	122	105
	45	108	108	254	551	254	108	108

AERIAL FCC 2016.25.090./095. FORCE DIAGRAM

shouldered

		Width 900 mm						
30°		135	135	135	90	135	135	135
Height 225 mm	45	88	151	461	1190	461	151	88
	45	111	199	638	1514	638	199	111
	45	129	230	808	1819	808	230	129
	45	133	206	730	1684	730	206	133
	45	137	183	576	1396	576	183	137

Support with feather key

		Width 900 mm						
30°		135	135	135	90	135	135	135
Height 225 mm	45	70	93	221	524	221	93	70
	45	89	124	306	666	306	124	89
	45	103	143	388	800	388	143	103
	45	106	128	351	741	351	128	106
	45	110	113	277	614	277	113	110

		Width 900 mm						
35°		135	135	135	90	135	135	135
Height 225 mm	45	88	151	463	1210	463	151	88
	45	110	201	639	1510	639	201	110
	45	129	232	807	1810	807	232	129
	45	133	208	730	1678	730	208	133
	45	138	184	582	1401	582	184	138

		Width 900 mm						
35°		135	135	135	90	135	135	135
Height 225 mm	45	70	97	236	581	236	97	70
	45	88	129	326	725	326	129	88
	45	103	148	411	869	411	148	103
	45	107	133	372	805	372	133	107
	45	110	118	297	672	297	118	110

		Width 900 mm						
40°		135	135	135	90	135	135	135
Height 225 mm	45	91	152	480	1244	480	152	91
	45	115	202	655	1539	655	202	115
	45	134	233	807	1808	807	233	134
	45	134	207	722	1661	722	207	134
	45	135	180	574	1389	574	180	135

		Width 900 mm						
40°		135	135	135	90	135	135	135
Height 225 mm	45	72	100	259	647	259	100	72
	45	92	133	354	800	354	133	92
	45	107	154	436	940	436	154	107
	45	107	136	390	864	390	136	107
	45	108	119	310	722	310	119	108

		Width 900 mm						
45°		135	135	135	90	135	135	135
Height 225 mm	45	93	153	498	1278	498	153	93
	45	120	203	671	1568	671	203	120
	45	138	234	807	1806	807	234	138
	45	135	205	713	1645	713	205	135
	45	132	177	566	1377	566	177	132

		Width 900 mm						
45°		135	135	135	90	135	135	135
Height 225 mm	45	75	104	284	716	284	104	75
	45	96	138	382	878	382	138	96
	45	111	159	460	1011	460	159	111
	45	108	140	407	921	407	140	108
	45	106	120	322	771	322	120	106

		Width 900 mm						
50°		135	135	135	90	135	135	135
Height 225 mm	45	97	155	521	1325	521	155	97
	45	125	206	693	1613	693	206	125
	45	145	237	815	1821	815	237	145
	45	138	206	712	1645	712	206	138
	45	130	175	563	1378	563	175	130

		Width 900 mm						
50°		135	135	135	90	135	135	135
Height 225 mm	45	78	108	313	795	313	108	78
	45	100	144	416	968	416	144	100
	45	116	166	489	1093	489	166	116
	45	110	144	427	987	427	144	110
	45	104	122	338	827	338	122	104

		Width 900 mm						
55°		135	135	135	90	135	135	135
Height 225 mm	45	100	155	539	1360	539	155	100
	45	130	207	709	1642	709	207	130
	45	150	238	815	1819	815	238	150
	45	139	204	703	1629	703	204	139
	45	127	171	555	1366	555	171	127

		Width 900 mm						
55°		135	135	135	90	135	135	135
Height 225 mm	45	80	112	340	870	340	112	80
	45	104	149	447	1051	447	149	104
	45	120	171	513	1164	513	171	120
	45	111	147	443	1042	443	147	111
	45	102	123	349	874	349	123	102

AERIAL FCC

2016.25.090./095.

FORCE DIAGRAM

shouldered

		Width 900 mm						
		135	135	135	90	135	135	135
Height 225 mm	45	103	156	557	1394	557	156	103
	45	134	208	725	1672	725	208	134
	45	155	238	815	1816	815	238	155
	45	140	203	694	1613	694	203	140
	45	125	168	546	1354	546	168	125

Support with feather key

		Width 900 mm						
		135	135	135	90	135	135	135
Height 225 mm	45	82	115	368	948	368	115	82
	45	108	154	479	1137	479	154	108
	45	124	176	538	1235	538	176	124
	45	112	150	458	1097	458	150	112
	45	100	124	361	921	361	124	100

65°

		Width 900 mm						
		135	135	135	90	135	135	135
Height 225 mm	45	105	157	575	1428	575	157	105
	45	139	209	741	1701	741	209	139
	45	160	239	815	1814	815	239	160
	45	141	202	686	1596	686	202	141
	45	122	164	538	1342	538	164	122

65°

		Width 900 mm						
		135	135	135	90	135	135	135
Height 225 mm	45	84	119	397	1028	397	119	84
	45	111	159	511	1225	511	159	111
	45	128	182	562	1306	562	182	128
	45	112	153	473	1149	473	153	112
	45	97	125	371	966	371	125	97

70°

		Width 900 mm						
		135	135	135	90	135	135	135
Height 225 mm	45	108	157	593	1462	593	157	108
	45	144	210	757	1730	757	210	144
	45	164	240	815	1811	815	240	164
	45	142	200	677	1580	677	200	142
	45	119	160	530	1330	530	160	119

70°

		Width 900 mm						
		135	135	135	90	135	135	135
Height 225 mm	45	87	123	427	1111	427	123	87
	45	115	164	545	1315	545	164	115
	45	132	187	587	1377	587	187	132
	45	113	156	488	1201	488	156	113
	45	95	125	382	1011	382	125	95

75°

		Width 900 mm						
		135	135	135	90	135	135	135
Height 225 mm	45	111	158	611	1497	611	158	111
	45	148	211	773	1759	773	211	148
	45	169	241	815	1809	815	241	169
	45	143	199	669	1563	669	199	143
	45	116	157	522	1318	522	157	116

75°

		Width 900 mm						
		135	135	135	90	135	135	135
Height 225 mm	45	89	126	458	1197	458	126	89
	45	119	169	580	1407	580	169	119
	45	136	193	612	1447	612	193	136
	45	114	159	501	1251	501	159	114
	45	93	125	391	1054	391	125	93



AERIAL FCC 2016.25.100./105.

Working width: 1000/1050 mm
Performance class: 2000 kN

AERIAL FCC
2016.25.100./105.
 SIZE TABLE

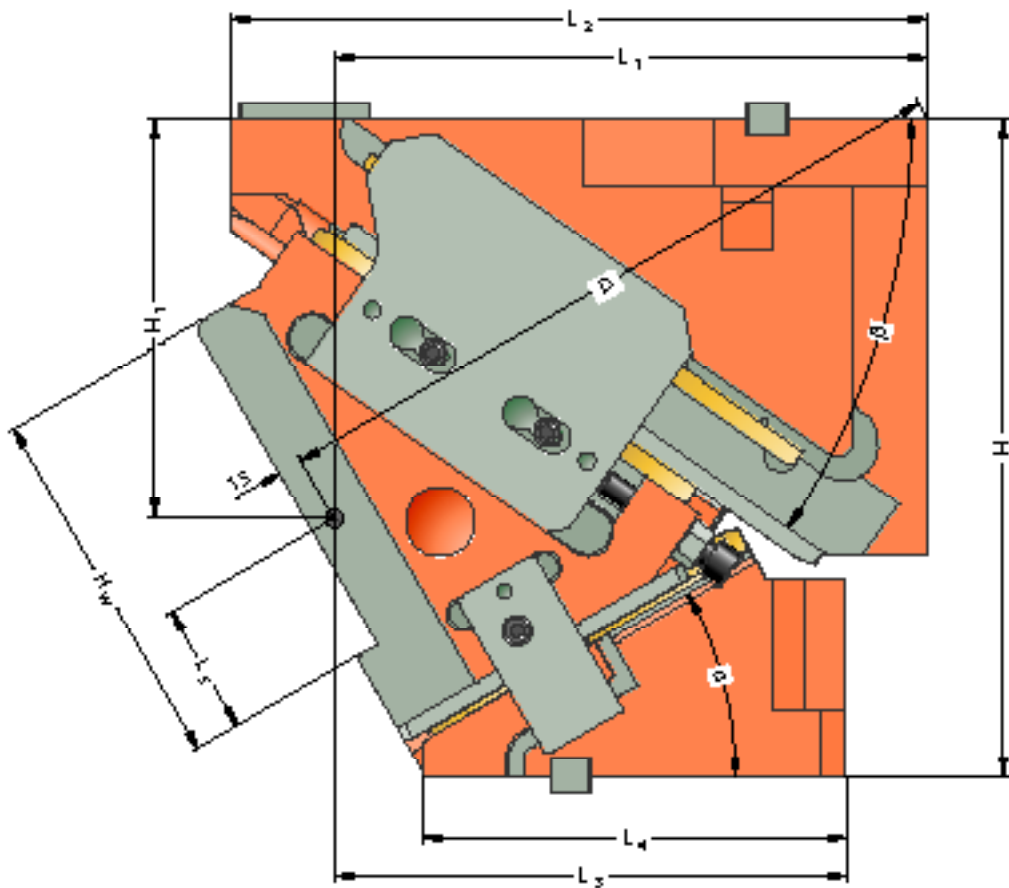
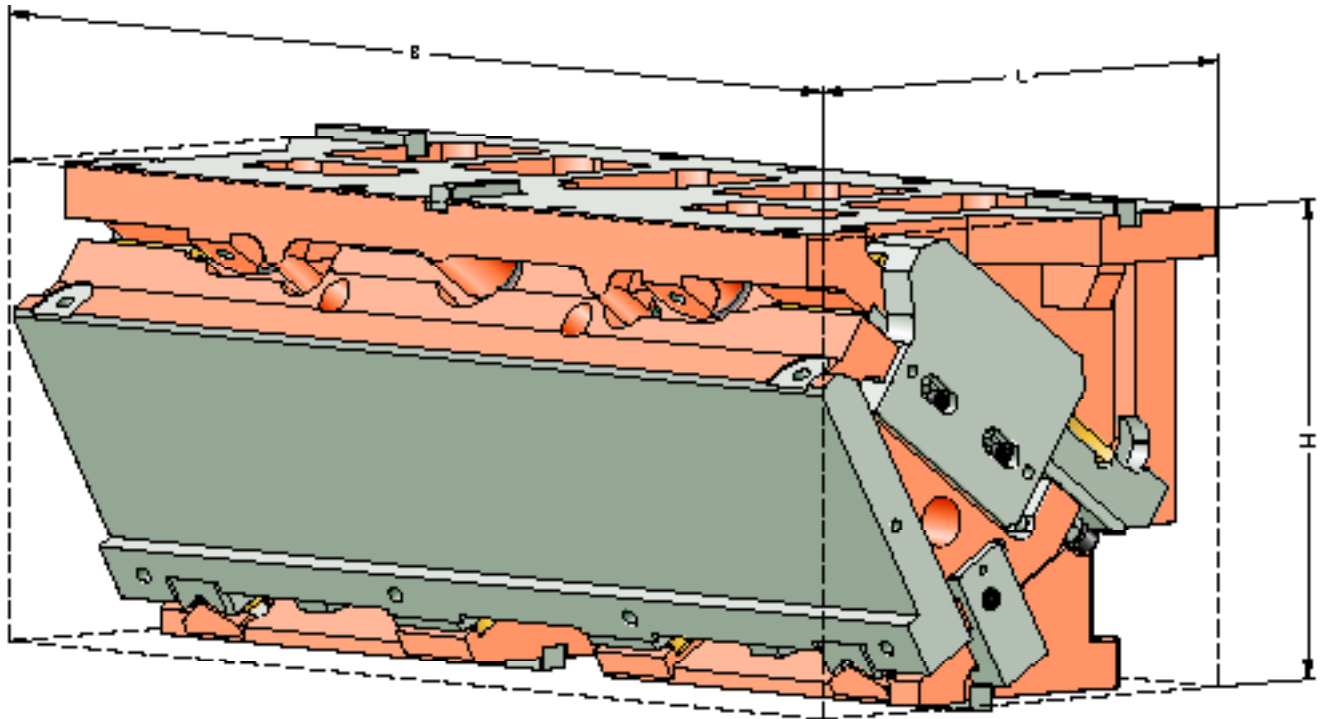

AERIAL FCC

2016.25.100./105.

SIZE TABLE

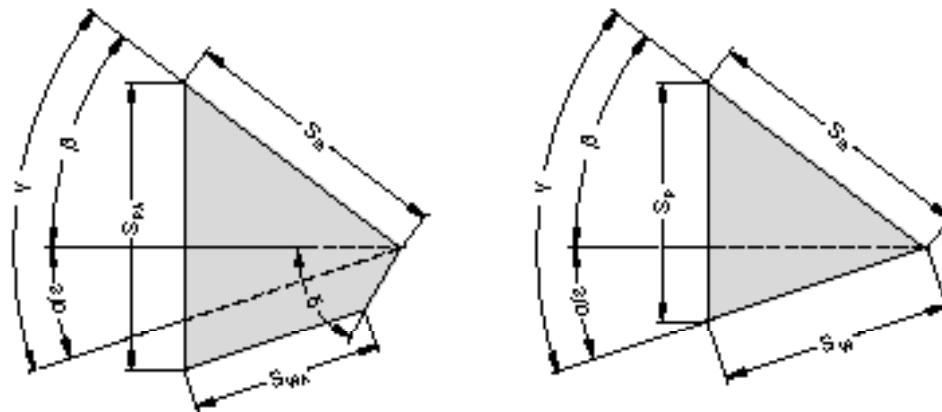

Order No.	L**	B***	H	H ₁	H _W	L ₁	L ₂	L ₃	L ₄	L ₅	D**	α	β	δ	S _W *	S _{WA} *	S _S	S _P *	S _{PA} *
2016.25.10□.	[mm]	[mm]	[mm]	[mm]	[mm]	[mm]	[mm]	[mm]	[mm]	[mm]	[mm]	[°]	[°]	[°]	[mm]	[mm]	[mm]	[mm]	[mm]
00.□000.02	395	10□0	400	208	220	365	370	280	305	80	395	0	50	45	-	45.7	100	-	95.2
05.□000.02	409.1	10□0	400	209	220	367.03	385	297.03	308	80	413.8	5	45	50	-	53.8	100	-	95.8
10.□000.02	428	10□0	400	208.61	220	374.12	385	304.12	302	80	434.7	10	45	45	-	56.6	100	-	95.5
15.□000.02	441.4	10□0	400	218.84	220	376.22	405	316.22	300	80	450	15	40	50	-	65.5	100	-	97.2
20.□000.02	449.3	10□0	400	229.69	220	373.27	410	298.27	270	80	459.3	20	40	45	-	68.8	100	-	99.8
25.□000.02	456.6	10□0	400	236.16	220	370.22	420	305.22	263	80	465.3	25	35	50	-	74.3	95	-	98.4
30.□000.02	458	10□0	400	243.22	220	362.01	425	312.01	258	80	465.1	30	35	45	-	79.5	95	-	103.2
35.□000.02	458.5	10□0	400	250.86	220	353.6	440	318.6	253	80	463.5	35	30	50	-	81.4	85	-	97.5
40.□000.02	462.9	10□0	400	259.08	220	349.93	450	324.93	247	80	464.6	40	25	55	-	93.0	85	-	104.0
45.□000.02	461.2	10□0	400	262.83	220	340.96	455	330.96	243	80	456.9	45	20	60	-	100.2	80	-	105.7
50.□000.02	483.2	10□0	400	267.09	220	356.64	480	336.64	264	80	463.9	50	10	-	107.2	-	70	94.3	-
55.□000.02	475.1	10□0	400	271.83	220	331.93	460	341.93	260	80	443.1	55	10	-	103.0	-	60	94.8	-
60.□000.02	480	10□0	400	277.01	220	316.78	470	326.78	237	80	428.3	60	10	-	108.3	-	55	103.4	-
65.□000.02	490	10□0	400	282.6	220	281.17	440	331.17	234	80	404.9	65	0	-	106.5	-	45	96.5	-
70.□000.02	505	10□0	400	288.54	220	265.05	435	335.05	232	80	391.8	70	0	-	117.0	-	40	109.9	-
75.□000.02	515	10□0	400	294.81	220	248.39	425	338.39	230	80	379.1	75	0	-	115.9	-	30	112.0	-

* Values rounded

** Values L, D measured for option with shouldered working surface

*** 10□0 = 1000 or 1050 mm

Mounting cam base:

Hexagon socket head cap screws DIN EN ISO 4762
Dowel pins DIN EN ISO 8735

8x M20 / Strength class min. 8.8
2x ø16

Mounting cam driver:

Hexagon socket head cap screws DIN EN ISO 4762
Dowel pins DIN EN ISO 8735

2x4 M16 / Strength class min. 8.8
2x2 ø12

AERIAL FCC
2016.25.100./105.
 EXPLODED VIEW

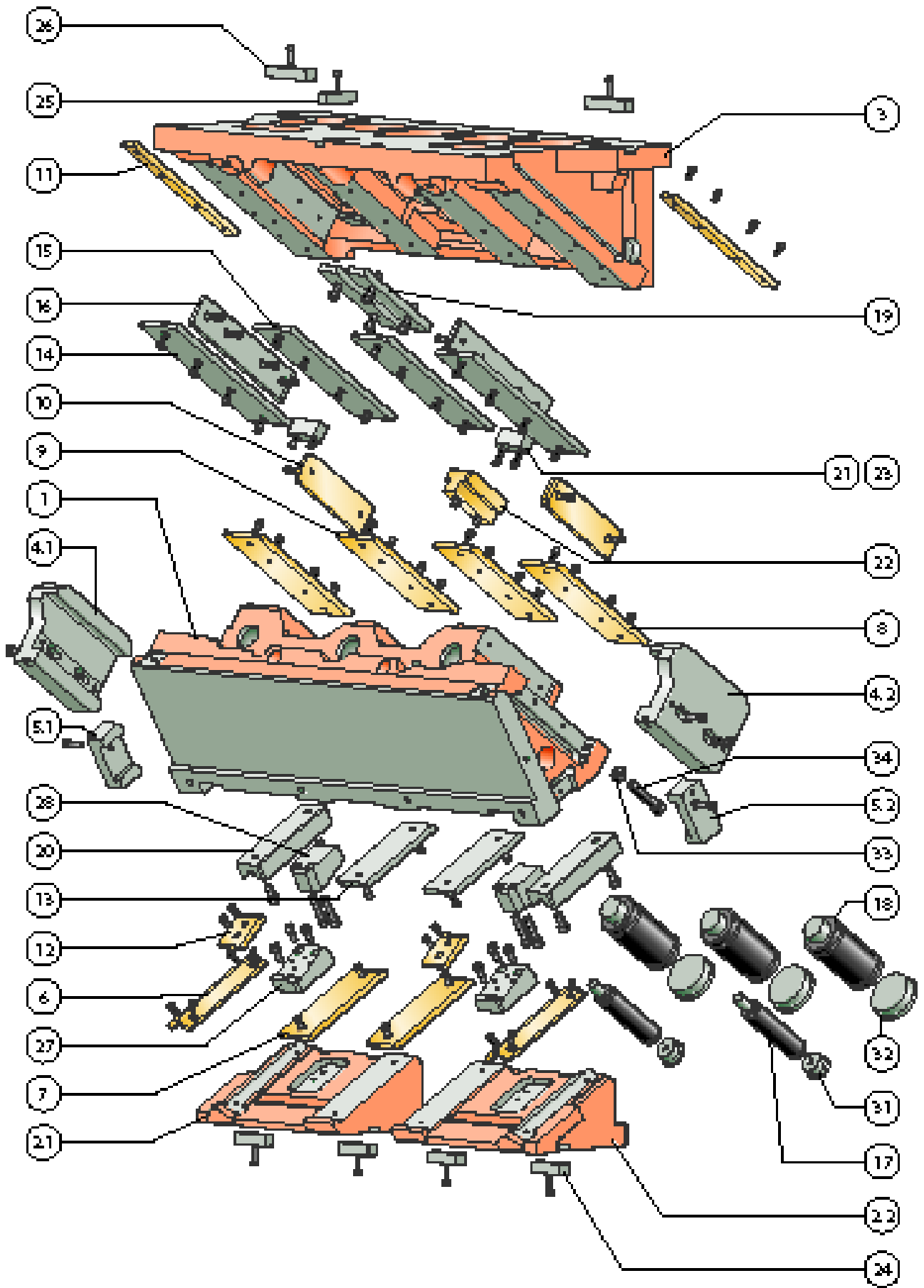

AERIAL FCC

2016.25.100./105.

PARTS LIST

Position	Piece	Designation	Material	spare part
1	1	Slider		
2.1	1	Driver, left		
2.2	1	Driver, right		
3	1	Slider cam base		
4.1	1	Clamp, left		x
4.2	1	Clamp, right		x
5.1	1	Positive return, left		x
5.2	1	Positive return, right		x
6	4	Sliding plate VDI	Bronze with solid lubricant	x
7	2	Sliding plate VDI	Bronze with solid lubricant	x
8	2	Sliding plate VDI	Bronze with solid lubricant	x
9	2	Sliding plate VDI	Bronze with solid lubricant	x
10	2	Sliding plate VDI	Bronze with solid lubricant	x
11	2	Sliding plate VDI	Bronze with solid lubricant	x
12**	2	Sliding plate VDI	Bronze with solid lubricant	x
13	2	Sliding plate VDI	Steel	x
14	2	Sliding plate VDI	Steel	x
15	2	Sliding plate VDI	Steel	x
16	2	Sliding plate VDI	Steel	x
17	2	Gas spring	2487.12.00500.125	x
18	3	Gas spring	2487.12.02400.□□□	x
19	2	Cover strip		x
20	2	Prismatic guide		x
21	2	Stop plate		x
22	1	Centre guide		x
23	2	Damper		x
24	4	Feather key (T-nut)		x
25	1	Feather key (T-nut)		x
26	2	Feather key (T-nut)		x
27**	2	Construction piece		x
28**	2	Slide pad		x
29* (not shown)	2	Curve wedge		x
30* (not shown)	2	Roller block		x
31	2	Locking screw		x
32	3	Locking screw		x
33	2	Ball-head screw		x
34	2	Hexagon nut		x

up to and including 45° with pre-acceleration

Optionally:

* Roll pre-acceleration (.1000. / .2000.)

** Plate pre-acceleration (.3000. / .4000.)

For inquiries or when ordering spare parts (x), we require the following data:

- Cam unit order no.
- Cam unit serial number
- Item number / Designation / Spare part

AERIAL FCC

2016.25.100./105.

SYSTEM AND SURROUNDING FORCES

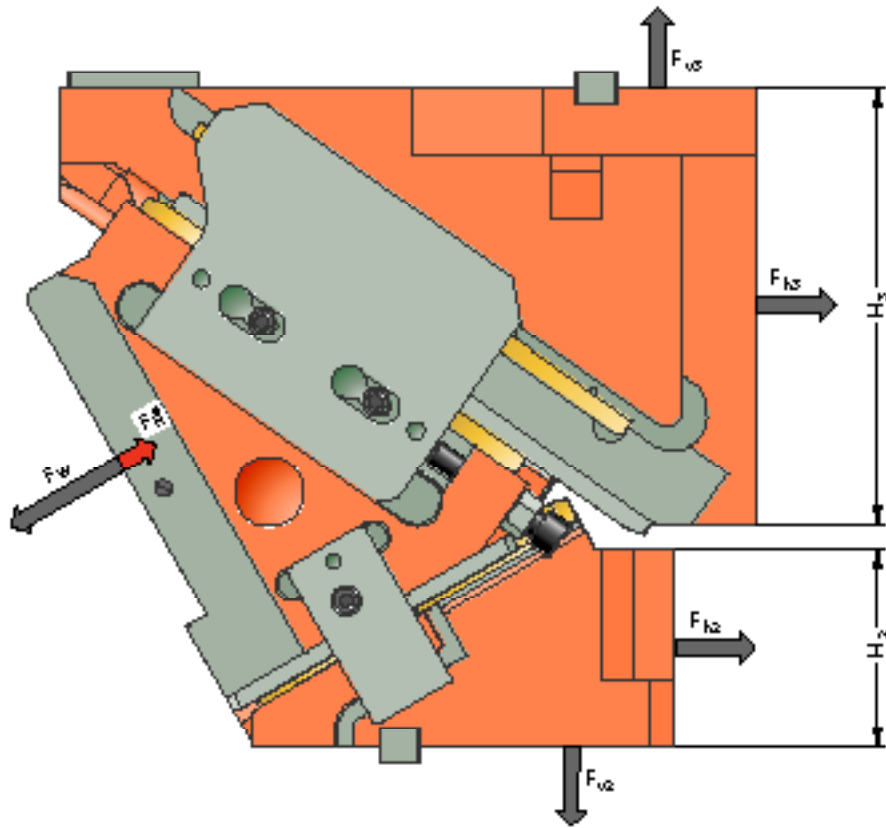

Order number	α [°]	F_W [kN]	F_R^* [kN]	F_{h2} [kN]	F_{v2} [kN]	F_{h3} [kN]	F_{v3} [kN]	H_2 [mm]	H_3 [mm]
2016.25.10□.00.□000.02	0	2000	149.3	0	1678	2000	1678	40	300
2016.25.10□.05.□000.02	5	2000	152.3	146	1672	1846	1846	40	275
2016.25.10□.10.□000.02	10	2000	169.6	243	1379	1726	1726	75	275
2016.25.10□.15.□000.02	15	2000	172.3	362	1353	1569	1870	80	255
2016.25.10□.20.□000.02	20	2000	195.1	479	1316	1400	2000	90	245
2016.25.10□.25.□000.02	25	2000	193.9	488	1047	1325	1892	110	215
2016.25.10□.30.□000.02	30	2000	225.1	466	808	1266	1808	120	210
2016.25.10□.35.□000.02	35	2000	219.4	535	764	1103	1911	140	210
2016.25.10□.40.□000.02	40	2000	221.1	599	714	933	2000	150	190
2016.25.10□.45.□000.02	45	2000	218.6	659	659	755	2074	170	170
2016.25.10□.50.□000.02	50	2000	186.1	885	742	401	2274	170	120
2016.25.10□.55.□000.02	55	2000	206.6	764	535	383	2173	180	115
2016.25.10□.60.□000.02	60	2000	256.5	630	364	370	2096	180	110
2016.25.10□.65.□000.02	65	2000	204.3	845	394	0	2207	190	85
2016.25.10□.70.□000.02	70	2000	246.0	684	249	0	2128	205	85
2016.25.10□.75.□000.02	75	2000	289.9	518	139	0	2071	220	85

* Retraction force values correspond to the spring-generated retraction force at the working point point

The forces F_{h2} , F_{v2} as well as F_{h3} , F_{v3} act on the tool environment at maximum working force F_W .

AERIAL FCC

2016.25.100./105.

FORCE DIAGRAM

shouldered

		Width 1000 mm						
		150	150	150	100	150	150	150
Height 225 mm	45	101	174	549	1217	549	174	101
	45	129	227	751	1722	751	227	129
	45	149	257	919	2021	919	257	149
	45	144	219	743	1707	743	219	144
	45	138	180	567	1393	567	180	138

		Width 1000 mm						
		150	150	150	100	150	150	150
Height 225 mm	45	100	174	543	1230	543	174	100
	45	128	227	747	1713	747	227	128
	45	148	258	918	2020	918	258	148
	45	144	221	755	1730	755	221	144
	45	140	184	581	1416	581	184	140

		Width 1000 mm						
		150	150	150	100	150	150	150
Height 225 mm	45	99	173	538	1242	538	173	99
	45	126	228	742	1703	742	228	126
	45	146	259	917	2019	917	259	146
	45	144	223	768	1753	768	223	144
	45	142	187	595	1439	595	187	142

		Width 1000 mm						
		150	150	150	100	150	150	150
Height 225 mm	45	97	173	532	1254	532	173	97
	45	124	228	737	1694	737	228	124
	45	145	260	917	2017	917	260	145
	45	145	226	780	1776	780	226	145
	45	144	191	608	1463	608	191	144

		Width 1000 mm						
		150	150	150	100	150	150	150
Height 225 mm	45	96	173	527	1267	527	173	96
	45	123	228	732	1685	732	228	123
	45	143	261	916	2016	916	261	143
	45	145	228	793	1798	793	228	145
	45	146	195	622	1486	622	195	146

		Width 1000 mm						
		150	150	150	100	150	150	150
Height 225 mm	45	95	173	522	1279	522	173	95
	45	121	228	728	1676	728	228	121
	45	142	262	916	2014	916	262	142
	45	145	230	805	1821	805	230	145
	45	148	198	635	1509	635	198	148

Support with feather key

		Width 1000 mm						
		150	150	150	100	150	150	150
Height 225 mm	45	81	104	165	243	165	104	81
	45	103	136	225	344	225	136	103
	45	119	154	276	404	276	154	119
	45	115	131	223	341	223	131	115
	45	111	108	170	279	170	108	111

		Width 1000 mm						
		150	150	150	100	150	150	150
Height 225 mm	45	80	104	179	295	179	104	80
	45	102	136	246	411	246	136	102
	45	118	155	303	485	303	155	118
	45	115	133	249	415	249	133	115
	45	112	110	192	340	192	110	112

		Width 1000 mm						
		150	150	150	100	150	150	150
Height 225 mm	45	79	104	194	348	194	104	79
	45	101	137	267	477	267	137	101
	45	117	156	330	565	330	156	117
	45	115	134	276	491	276	134	115
	45	114	112	214	403	214	112	114

		Width 1000 mm						
		150	150	150	100	150	150	150
Height 225 mm	45	78	104	208	401	208	104	78
	45	100	137	287	542	287	137	100
	45	116	156	358	645	358	156	116
	45	116	135	304	568	304	135	116
	45	115	115	237	468	237	115	115

		Width 1000 mm						
		150	150	150	100	150	150	150
Height 225 mm	45	77	104	221	456	221	104	77
	45	98	137	308	607	308	137	98
	45	115	157	385	726	385	157	115
	45	116	137	333	647	333	137	116
	45	117	117	261	535	261	117	117

		Width 1000 mm						
		150	150	150	100	150	150	150
Height 225 mm	45	76	104	235	512	235	104	76
	45	97	137	327	670	327	137	97
	45	114	157	412	806	412	157	114
	45	116	138	362	728	362	138	116
	45	119	119	286	604	286	119	119

AERIAL FCC

2016.25.100./105.

FORCE DIAGRAM

shouldered

		Width 1000 mm						
		150	150	150	100	150	150	150
Height 225 mm	45	94	173	516	1291	516	173	94
	45	120	229	723	1667	723	229	120
	45	140	263	915	2013	915	263	140
	45	145	232	818	1844	818	232	145
	45	150	202	649	1533	649	202	150

Support with feather key

		Width 1000 mm						
		150	150	150	100	150	150	150
Height 225 mm	45	75	107	248	568	248	107	75
	45	96	142	347	733	347	142	96
	45	112	163	439	886	439	163	112
	45	116	144	393	811	393	144	116
	45	120	125	312	674	312	125	120

35°

		Width 1000 mm						
		150	150	150	100	150	150	150
Height 225 mm	45	93	173	511	1304	511	173	93
	45	118	229	718	1658	718	229	118
	45	139	264	915	2012	915	264	139
	45	146	234	830	1867	830	234	146
	45	152	205	663	1556	663	205	152

35°

		Width 1000 mm						
		150	150	150	100	150	150	150
Height 225 mm	45	74	111	261	626	261	111	74
	45	95	146	366	796	366	146	95
	45	111	169	466	966	466	169	111
	45	117	150	423	896	423	150	117
	45	122	131	338	747	338	131	122

40°

		Width 1000 mm						
		150	150	150	100	150	150	150
Height 225 mm	45	96	173	535	1350	535	173	96
	45	124	231	736	1690	736	231	124
	45	145	266	918	2014	918	266	145
	45	147	233	823	1853	823	233	147
	45	150	201	655	1547	655	201	150

40°

		Width 1000 mm						
		150	150	150	100	150	150	150
Height 225 mm	45	77	114	289	702	289	114	77
	45	99	152	397	879	397	152	99
	45	116	175	496	1047	496	175	116
	45	118	154	444	964	444	154	118
	45	120	132	354	804	354	132	120

45°

		Width 1000 mm						
		150	150	150	100	150	150	150
Height 225 mm	45	99	173	558	1396	558	173	99
	45	129	232	754	1722	754	232	129
	45	151	268	921	2016	921	268	151
	45	149	232	816	1839	816	232	149
	45	147	196	648	1537	648	196	147

45°

		Width 1000 mm						
		150	150	150	100	150	150	150
Height 225 mm	45	79	117	318	782	318	117	79
	45	104	158	430	965	430	158	104
	45	121	182	525	1129	525	182	121
	45	119	158	465	1030	465	158	119
	45	117	133	369	861	369	133	117

50°

		Width 1000 mm						
		150	150	150	100	150	150	150
Height 225 mm	45	103	173	582	1442	582	173	103
	45	135	234	772	1755	772	234	135
	45	158	270	925	2019	925	270	158
	45	151	231	809	1825	809	231	151
	45	144	191	641	1528	641	191	144

50°

		Width 1000 mm						
		150	150	150	100	150	150	150
Height 225 mm	45	82	121	349	865	349	121	82
	45	108	164	463	1053	463	164	108
	45	126	189	555	1211	555	189	126
	45	121	161	485	1095	485	161	121
	45	115	134	384	917	384	134	115

55°

		Width 1000 mm						
		150	150	150	100	150	150	150
Height 225 mm	45	106	173	606	1488	606	173	106
	45	141	236	790	1787	790	236	141
	45	164	272	928	2021	928	272	164
	45	152	229	801	1811	801	229	152
	45	141	186	633	1518	633	186	141

55°

		Width 1000 mm						
		150	150	150	100	150	150	150
Height 225 mm	45	85	124	382	952	382	124	85
	45	113	170	498	1144	498	170	113
	45	131	196	585	1294	585	196	131
	45	122	165	505	1159	505	165	122
	45	113	134	399	972	399	134	113

AERIAL FCC

2016.25.100./105.

FORCE DIAGRAM

shouldered

		Width 1000 mm						
		150	150	150	100	150	150	150
Height 225 mm	45	109	173	629	1534	629	173	109
	45	146	237	808	1820	808	237	146
	45	170	274	931	2024	931	274	170
	45	154	228	794	1797	794	228	154
	45	138	182	626	1509	626	182	138

Support with feather key

		Width 1000 mm						
		150	150	150	100	150	150	150
Height 225 mm	45	88	128	415	1043	415	128	88
	45	117	176	533	1237	533	176	117
	45	136	203	615	1376	615	203	136
	45	123	169	524	1222	524	169	123
	45	110	134	413	1026	413	134	110

65°

		Width 1000 mm						
		150	150	150	100	150	150	150
Height 225 mm	45	113	173	653	1580	653	173	113
	45	152	239	826	1852	826	239	152
	45	176	277	935	2026	935	277	176
	45	156	227	787	1783	787	227	156
	45	135	177	618	1499	618	177	135

65°

		Width 1000 mm						
		150	150	150	100	150	150	150
Height 225 mm	45	90	131	451	1138	451	131	90
	45	122	182	570	1333	570	182	122
	45	141	210	645	1459	645	210	141
	45	124	172	543	1284	543	172	124
	45	108	135	427	1079	427	135	108

70°

		Width 1000 mm						
		150	150	150	100	150	150	150
Height 225 mm	45	116	173	677	1627	677	173	116
	45	157	241	844	1884	844	241	157
	45	182	279	938	2029	938	279	182
	45	157	225	780	1770	780	225	157
	45	132	172	611	1490	611	172	132

70°

		Width 1000 mm						
		150	150	150	100	150	150	150
Height 225 mm	45	93	135	487	1236	487	135	93
	45	126	188	608	1432	608	188	126
	45	146	217	675	1542	675	217	146
	45	126	176	561	1345	561	176	126
	45	106	134	440	1132	440	134	106

75°

		Width 1000 mm						
		150	150	150	100	150	150	150
Height 225 mm	45	120	173	700	1673	700	173	120
	45	163	243	862	1917	862	243	163
	45	188	281	941	2031	941	281	188
	45	159	224	772	1756	772	224	159
	45	129	168	604	1480	604	168	129

75°

		Width 1000 mm						
		150	150	150	100	150	150	150
Height 225 mm	45	96	138	525	1338	525	138	96
	45	130	194	647	1534	647	194	130
	45	151	225	706	1625	706	225	151
	45	127	179	579	1405	579	179	127
	45	103	134	453	1184	453	134	103

INTRODUCTION AND TABLE OF CONTENTS

ENGINEERING

2016.24. AERIAL FCC BAK

DAIMLER, VOLVO,
VOLKSWAGEN GROUP

2016.25. AERIAL FCC BAK

DAIMLER, VOLVO,
VOLKSWAGEN GROUP

2016.207. AERIAL ECO LINE

2016.208. AERIAL ECO LINE

CUSTOMER-SPECIFIC SERVICES

APPENDIX

EMERGENCY SITUATION / CONTACTS



**AERIAL ECO LINE
2016.207.**

AERIAL ECO LINE 2016.207.

FIBRO ECO LINE cam units series 2016.207. are an economical alternative for cam unit dies with high lifetime requirements. When properly maintained, these cam units allow a high number of cycles with sufficient precision over the entire nominal lifetime.

The gas springs for the cam return stroke can be exchanged without disassembling the cam unit with sufficient free space in the tool.

From a cam unit width of 165 mm, the cam units of the ECO LINE 2016.207. series are equipped with a roll pre-acceleration up to an angle of 25°.

The optional machining of the working surface per your specifications fulfil the requirements for typical toolmaking tolerances.

Design features:

- Prismatic guide against cam driver, flat guide against cam base
- Sliding surfaces hardened steel / bronze with solid lubricant
- Gas springs

FIBRO ECO LINE cam units series 2016.207. are available in the widths from 70 to 400 mm and in the angular variants 0° to 60 ° (gradation 5°).

Order number	Width [mm]	Performance class [kN]*	Page
2016.207.□□.007.□□□.21	70	100	223
2016.207.□□.008.□□□.21	80	150	229
2016.207.□□.016.□□□.21	165	300	235
2016.207.□□.020.□□□.21	200	350	241
2016.207.□□.030.□□□.21	300	450	247
2016.207.□□.040.□□□.21	400	450	253

* For exact power values, please refer to the specifications of the respective cam unit type

Ordering example:

FIBRO ECO LINE cam unit, aerial, width 165 mm	=	2016.207.□□.016.□□□.21
Cam unit angle $\alpha = 60^\circ$	=	60.
Cam unit stroke according to flow diagram (no option)	=	100.
Order number	=	2016.207. 60. 016. 100. 21



**AERIAL
ECO LINE
2016.207.□□.007.**

Working width: 70 mm
Performance class: 100 kN

AERIAL ECO LINE
2016.207.□□.007.
 SIZE TABLE

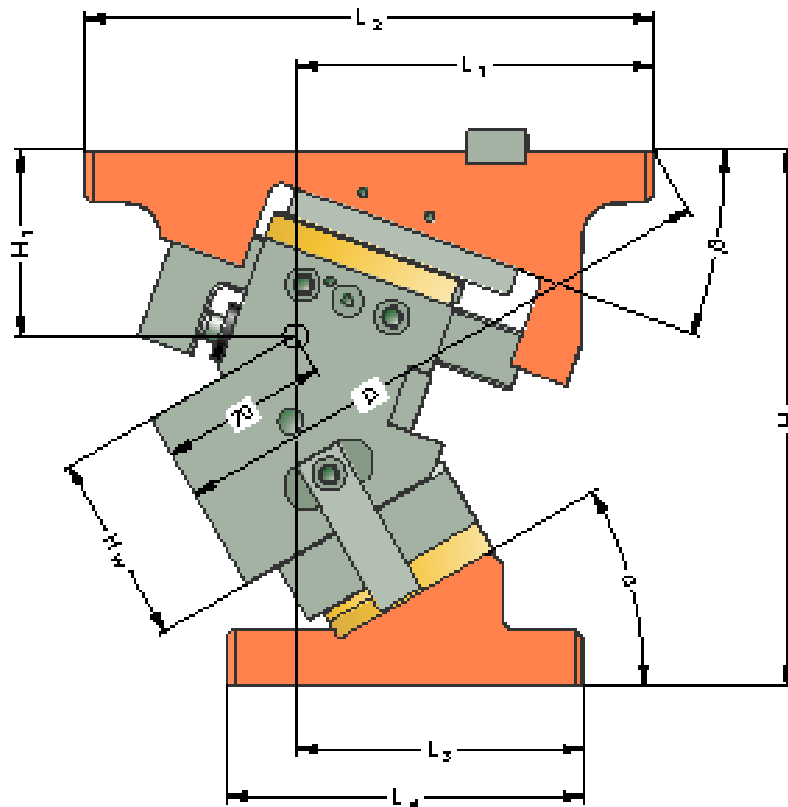
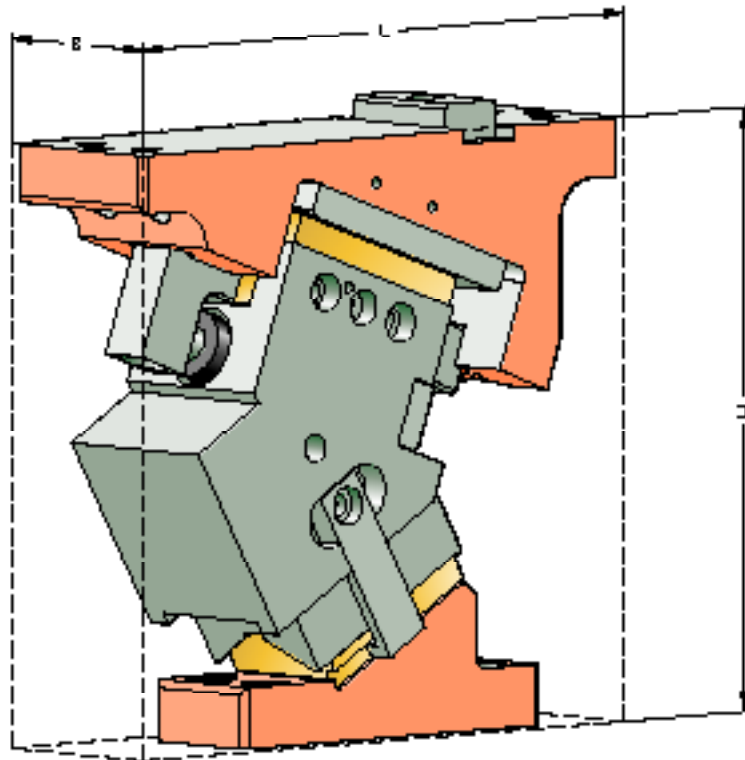

AERIAL ECO LINE

2016.207.□□.007.

SIZE TABLE

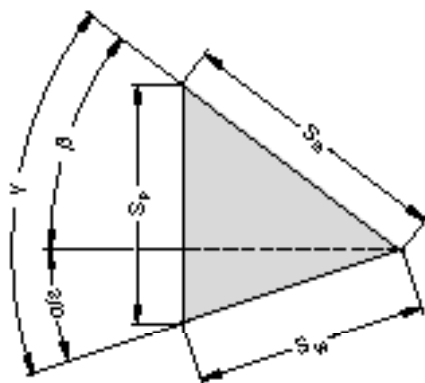

Order number	L [mm]	B [mm]	H [mm]	H ₁ [mm]	H _W [mm]	L ₁ * [mm]	L ₂ [mm]	L ₃ * [mm]	L ₄ [mm]	L ₅ [mm]	D* [mm]	α [°]	β [°]	S _W * [mm]	S _S [mm]	S _P * [mm]
2016.207.00.007.019.21	252	70	225	85	75	167.4	240	65.4	150	0	237.4	0	50	19.3	30	23.0
2016.207.05.007.021.21	242	70	225	80.2	75	165.1	240	73.1	150	0	241.5	5	45	21.3	30	23.1
2016.207.10.007.023.21	240	70	225	76.6	75	163.9	240	82.9	150	0	244.7	10	40	23.3	30	23.3
2016.207.15.007.025.21	240	70	225	78.5	75	149.9	240	92.9	150	0	235.1	15	35	25.4	30	23.8
2016.207.20.007.027.21	240	70	225	75.7	75	158.8	240	106.8	150	0	245.1	20	30	27.6	30	24.5
2016.207.25.007.030.21	240	70	225	75.9	75	160	240	118	150	0	247.1	25	25	30.0	30	25.4
2016.207.30.007.032.21	240	70	225	78	75	150.9	240	120.9	150	0	239.7	30	20	32.6	30	26.5
2016.207.35.007.035.21	240	70	225	77.1	75	153.3	240	136.3	150	0	239.8	35	15	35.4	30	28.1
2016.207.40.007.038.21	240	70	225	80.1	75	151.2	240	147.2	150	0	237.3	40	10	38.6	30	30.0
2016.207.45.007.042.21	242	70	225	81.8	75	148.7	240	150.7	150	0	232.9	45	5	42.3	30	32.5
2016.207.50.007.046.21	261	70	225	81.5	75	146	240	167	150	0	226.3	50	0	46.7	30	35.8
2016.207.55.007.052.21	263	70	225	88.7	75	150.4	240	173.4	150	0	228.9	55	0	52.3	30	42.8
2016.207.60.007.060.21	275	70	225	95.2	75	150.8	240	185.8	150	0	227.9	60	0	60.0	30	52.0

* Values rounded

Mounting cam base:

Hexagon socket head cap screws DIN EN ISO 4762
Dowel pins DIN EN ISO 8735

4x M10 / Strength class min. 8.8
2x ø10

Mounting cam driver:

Hexagon socket head cap screws DIN EN ISO 4762
Dowel pins DIN EN ISO 8735

4x M10 / Strength class min. 8.8
2x ø10

AERIAL ECO LINE
2016.207.□□.007.
 EXPLODED VIEW

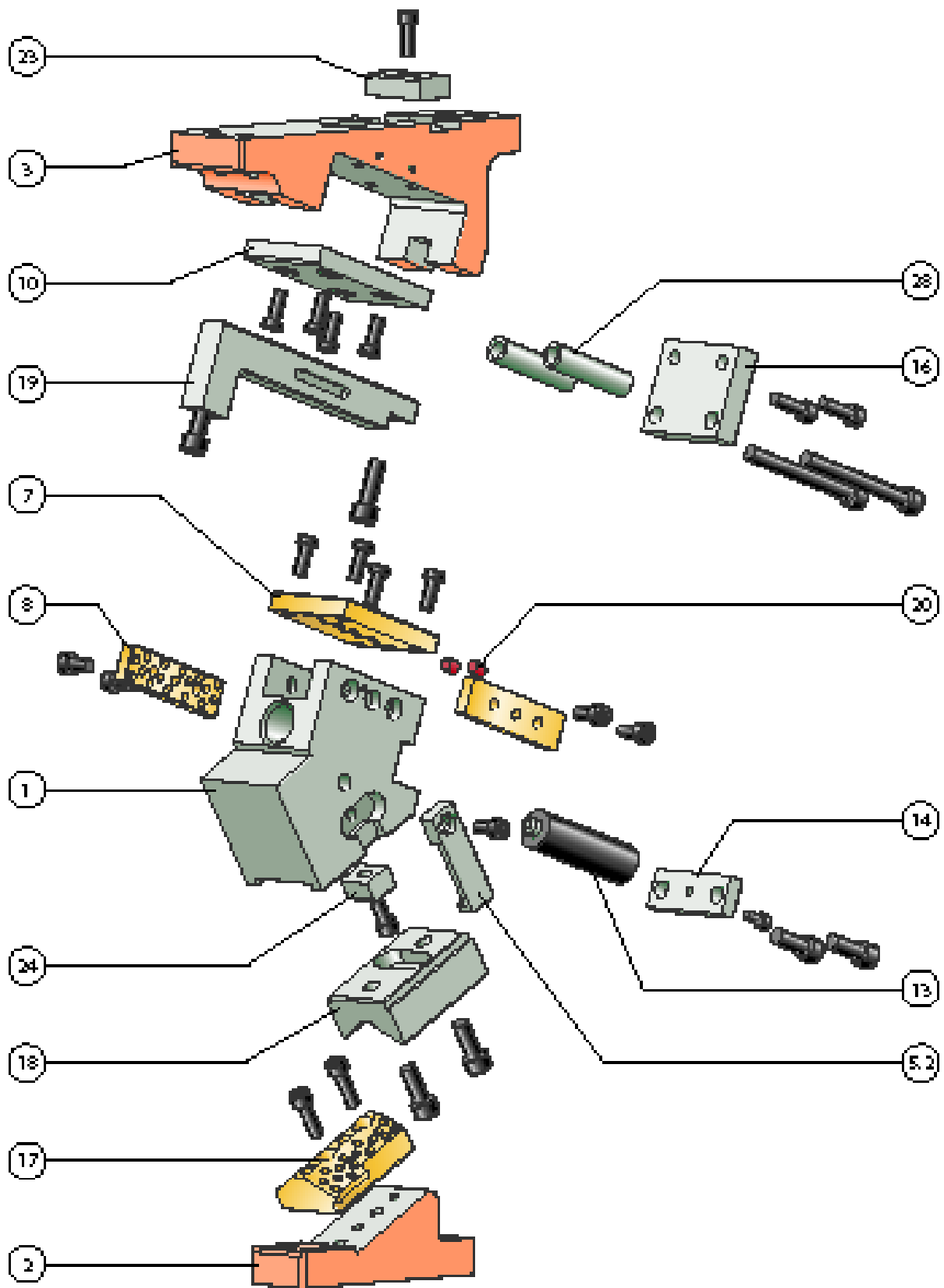

AERIAL ECO LINE

2016.207.□□.007.

PARTS LIST

Position	Piece	Designation	Material	spare part
1	1	Body		
2	1	Driver		
3	1	Base		
4.1				
4.2				
5.1				x
5.2	1	Positive return, right		x
6				
7	1	Sliding plate	Bronze with solid lubricant	x
8	2	Sliding plate	Bronze with solid lubricant	x
9				
10	1	Sliding plate	Steel	x
11				
12				
13	1	Gas spring		x
14	1	Stop plate		x
15				
16	1	Lockout system		x
17	1	Slide pad	Bronze with solid lubricant	x
18	1	Prismatic guide	Steel	x
19	1	Centre guide		x
20	2	Damper		x
21				
22				
23	1	Feather key		x
24	1	Feather key		x
25				
26				
27				
28	2	Spacer		x

For inquiries or when ordering spare parts (x), we require the following data:

- Cam unit order no.
- Cam unit serial no.
- Item number / Designation / Spare part

AERIAL ECO LINE

2016.207.□□.007.

SYSTEM AND SURROUNDING FORCES

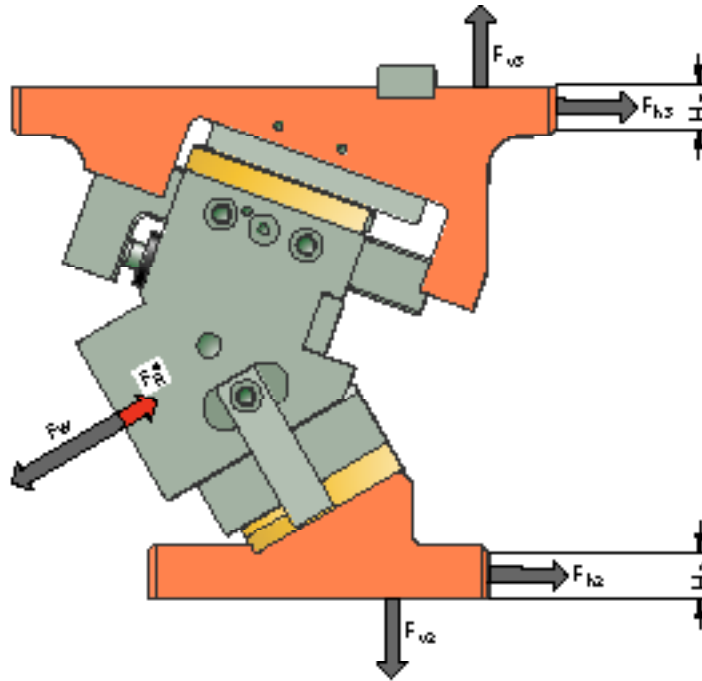

Order number	α [°]	F_w [kN]	F_R^* [kN]	F_{h2} [kN]	F_{v2} [kN]	F_{h3} [kN]	F_{v3} [kN]	H_2 [mm]	H_3 [mm]
2016.207.00.007.019.21	0	98	2.3	0	82	98	82	20	19
2016.207.05.007.021.21	5	98	2.3	7	82	90	90	20	19
2016.207.10.007.023.21	10	98	2.4	14	81	82	98	20	19
2016.207.15.007.025.21	15	98	2.4	21	79	73	105	20	19
2016.207.20.007.027.21	20	98	2.4	28	77	64	111	20	19
2016.207.25.007.030.21	25	98	2.4	35	75	54	116	20	19
2016.207.30.007.032.21	30	98	2.4	41	71	44	120	20	19
2016.207.35.007.035.21	35	98	2.4	47	67	33	124	20	19
2016.207.40.007.038.21	40	98	2.5	53	63	22	126	20	19
2016.207.45.007.042.21	45	98	2.5	58	58	11	127	20	19
2016.207.50.007.046.21	50	98	2.5	63	53	0	128	20	19
2016.207.55.007.052.21	55	98	2.7	56	39	0	120	20	19
2016.207.60.007.060.21	60	98	3.1	49	28	0	113	20	19

* Retraction force values correspond to the spring-generated retraction force at the working point

The forces F_{h2} , F_{v2} as well as F_{h3} , F_{v3} act on the tool environment at maximum working force F_w .

AERIAL ECO LINE
2016.207.□□.008.
 SIZE TABLE

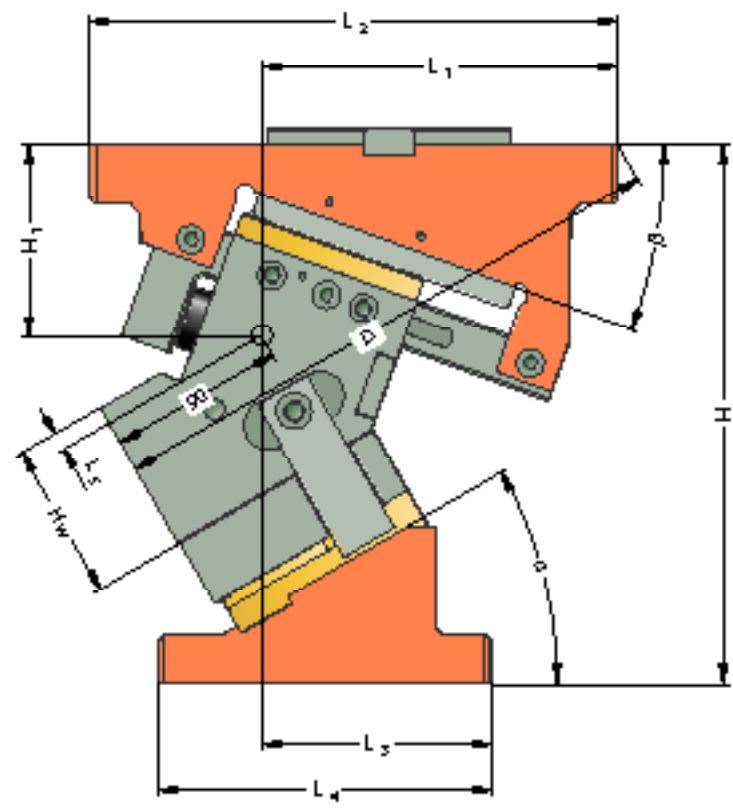
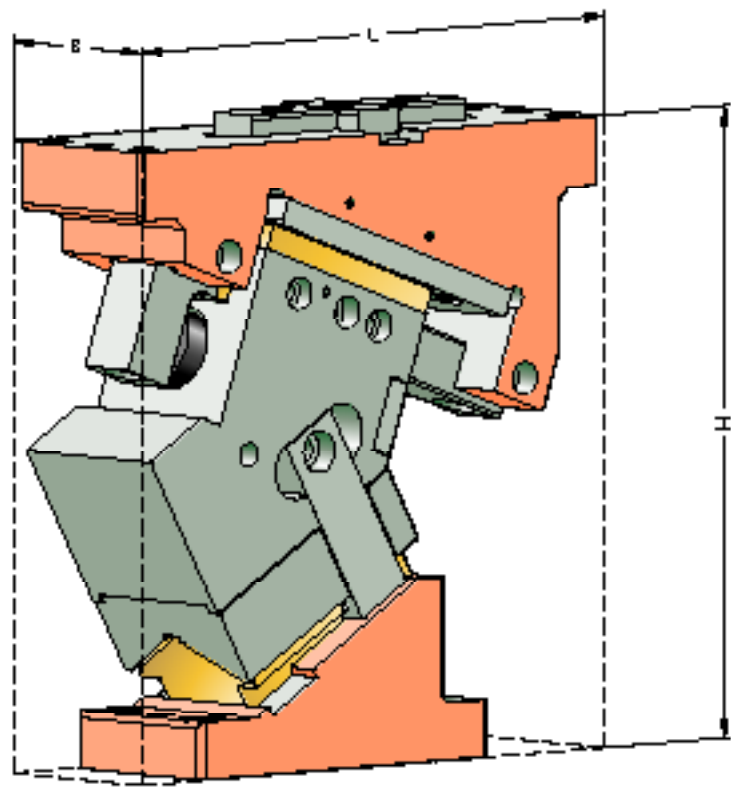

AERIAL ECO LINE

2016.207.□□.008.

SIZE TABLE

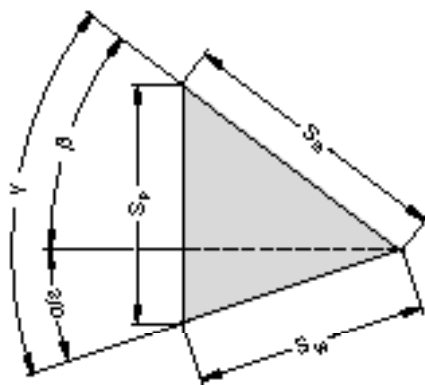

Order number	L [mm]	B [mm]	H [mm]	H ₁ [mm]	H _W [mm]	L ₁ * [mm]	L ₂ [mm]	L ₃ * [mm]	L ₄ [mm]	L ₅ [mm]	D* [mm]	α [°]	β [°]	S _W * [mm]	S _s [mm]	S _p * [mm]
2016.207.00.008.032.21	305	80	275	119	75	190	270	55	170	9	280	0	50	32.1	50	38.3
2016.207.05.008.035.21	295	80	275	117.1	75	190.9	270	65.9	170	9	290.4	5	45	35.5	50	38.4
2016.207.10.008.038.21	280	80	275	111.1	75	187.3	270	77.3	170	9	293.7	10	40	38.9	50	38.9
2016.207.15.008.042.21	281	80	275	106.1	75	191.2	270	86.2	170	9	302.2	15	35	42.4	50	39.7
2016.207.20.008.046.21	276	80	275	102.2	75	188.5	270	93.5	170	9	302.1	20	30	46.1	50	40.8
2016.207.25.008.050.21	272	80	275	99.4	75	186.1	270	106.1	170	9	300.7	25	25	50.0	50	42.3
2016.207.30.008.054.21	270	80	275	97.7	75	181.9	270	116.9	170	9	296.4	30	20	54.3	50	44.2
2016.207.35.008.059.21	270	80	275	97.1	75	181.8	270	126.8	170	9	294.6	35	15	59.0	50	46.8
2016.207.40.008.064.21	270	80	275	96.8	75	177.6	270	142.6	170	9	288.3	40	10	64.3	50	50.0
2016.207.45.008.070.21	270	80	275	99.3	75	177.5	270	147.5	170	9	285.7	45	5	70.4	50	54.2
2016.207.50.008.077.21	270	80	275	102.1	75	173.1	270	158.1	170	9	279.5	50	0	77.8	50	59.6
2016.207.55.008.087.21	270	80	275	106	75	172.4	270	172.4	170	9	275.7	55	0	87.2	50	71.4
2016.207.60.008.100.21	270	80	275	112.5	75	181.2	270	181.2	170	9	278	60	0	100.0	50	86.6

* Values rounded

Mounting cam base:

Hexagon socket head cap screws DIN EN ISO 4762
Dowel pins DIN EN ISO 8735

4x M12 / Strength class min. 8.8
2x ø12

Mounting cam driver:

Hexagon socket head cap screws DIN EN ISO 4762
Dowel pins DIN EN ISO 8735

4x M12 / Strength class min. 8.8
2x ø12

AERIAL ECO LINE
2016.207.□□.008.
 EXPLODED VIEW

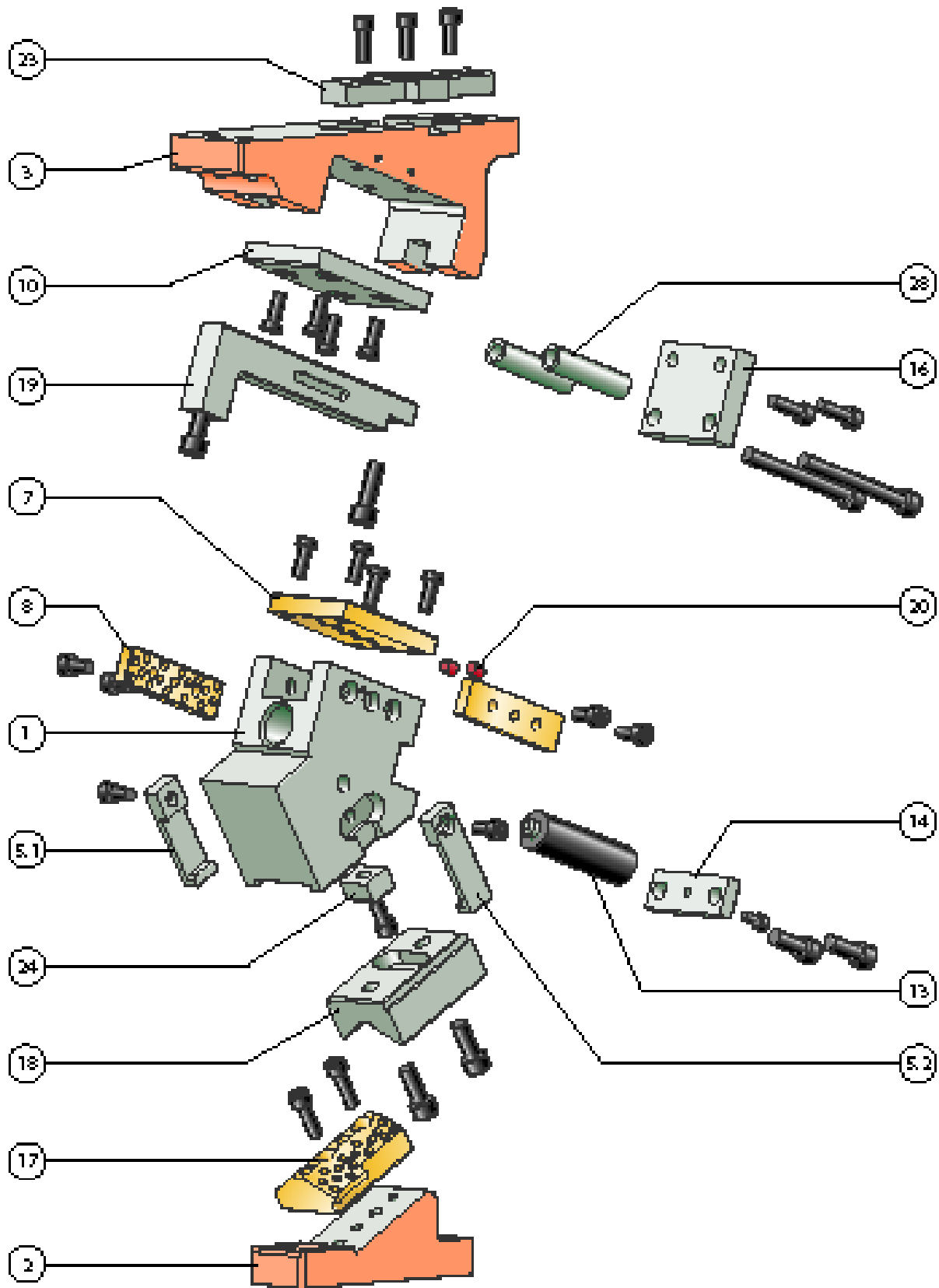

AERIAL ECO LINE

2016.207.□□.008.

PARTS LIST

Position	Piece	Designation	Material	spare part
1	1	Body		
2	1	Driver		
3	1	Base		
4.1				
4.2				
5.1	1	Positive return, left		x
5.2	1	Positive return, right		x
6				
7	1	Sliding plate	Bronze with solid lubricant	x
8	2	Sliding plate	Bronze with solid lubricant	x
9				
10	1	Sliding plate	Steel	x
11				
12				
13	1	Gas spring		x
14	1	Stop plate		x
15				
16	1	Lockout system		x
17	1	Slide pad	Bronze with solid lubricant	x
18	1	Prismatic guide	Steel	x
19	1	Centre guide		x
20	2	Damper		x
21				
22				
23	3	Feather key		x
24	1	Feather key		x
25				
26				
27				
28	2	Spacer		x

For inquiries or when ordering spare parts (x), we require the following data:

- Cam unit order no.
- Cam unit serial no.
- Item number / Designation / Spare part

AERIAL ECO LINE

2016.207.□□.008.

SYSTEM AND SURROUNDING FORCES

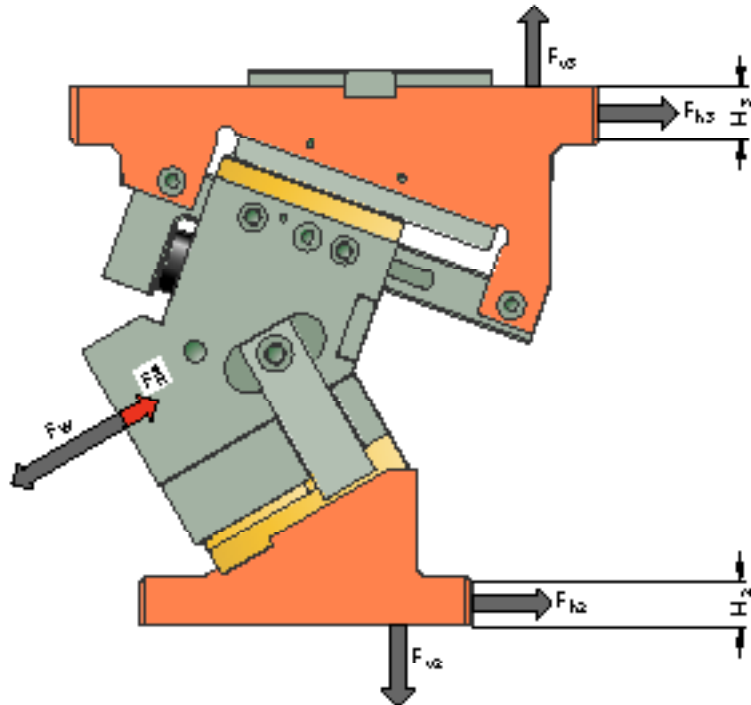

Order number	α [°]	F_W [kN]	F_R^* [kN]	F_{h2} [kN]	F_{v2} [kN]	F_{h3} [kN]	F_{v3} [kN]	H_2 [mm]	H_3 [mm]
2016.207.00.008.032.21	0	166	2.4	0	139	166	139	22	27
2016.207.05.008.035.21	5	166	2.4	12	139	153	153	22	27
2016.207.10.008.038.21	10	166	2.4	24	137	139	166	22	27
2016.207.15.008.042.21	15	166	2.4	36	135	124	178	22	27
2016.207.20.008.046.21	20	166	2.5	48	131	108	188	22	27
2016.207.25.008.050.21	25	166	2.5	59	126	92	196	22	27
2016.207.30.008.054.21	30	166	2.5	70	121	74	204	22	27
2016.207.35.008.059.21	35	166	2.5	80	114	56	209	22	27
2016.207.40.008.064.21	40	166	2.5	90	107	38	213	22	27
2016.207.45.008.070.21	45	166	2.5	98	98	19	216	22	27
2016.207.50.008.077.21	50	166	2.5	107	90	0	217	22	27
2016.207.55.008.087.21	55	166	2.7	95	67	0	203	22	27
2016.207.60.008.100.21	60	166	3.0	83	48	0	192	22	27

* Retraction force values correspond to the spring-generated retraction force at the working point

The forces F_{h2} , F_{v2} as well as F_{h3} , F_{v3} act on the tool environment at maximum working force F_W .



**AERIAL
ECO LINE
2016.207.□□.016.**

Working width: 165 mm
Performance class: 300 kN

AERIAL ECO LINE
2016.207.□□.016.
 SIZE TABLE

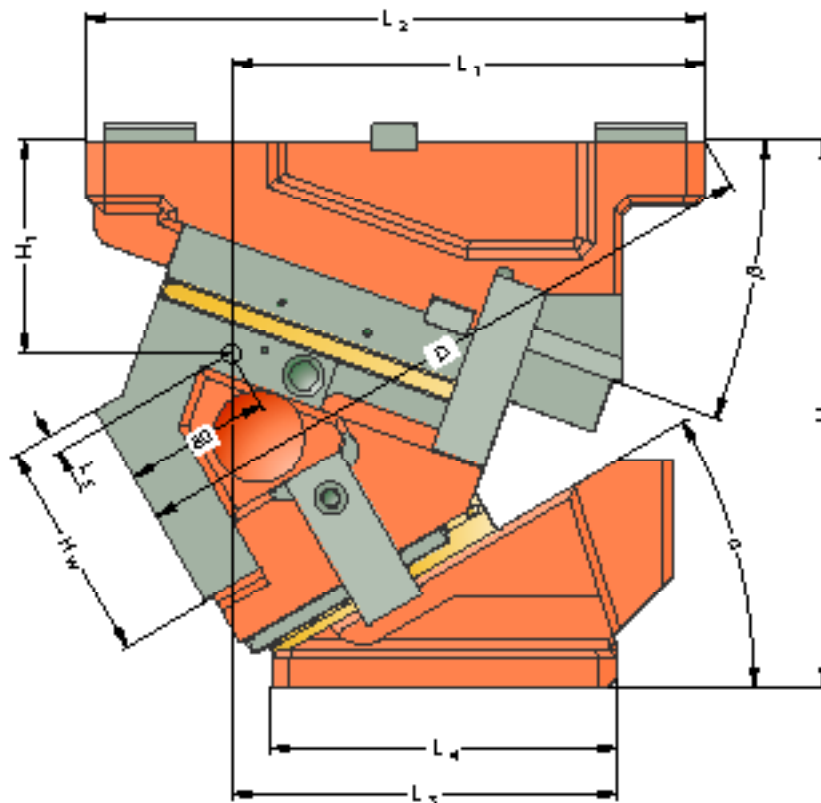
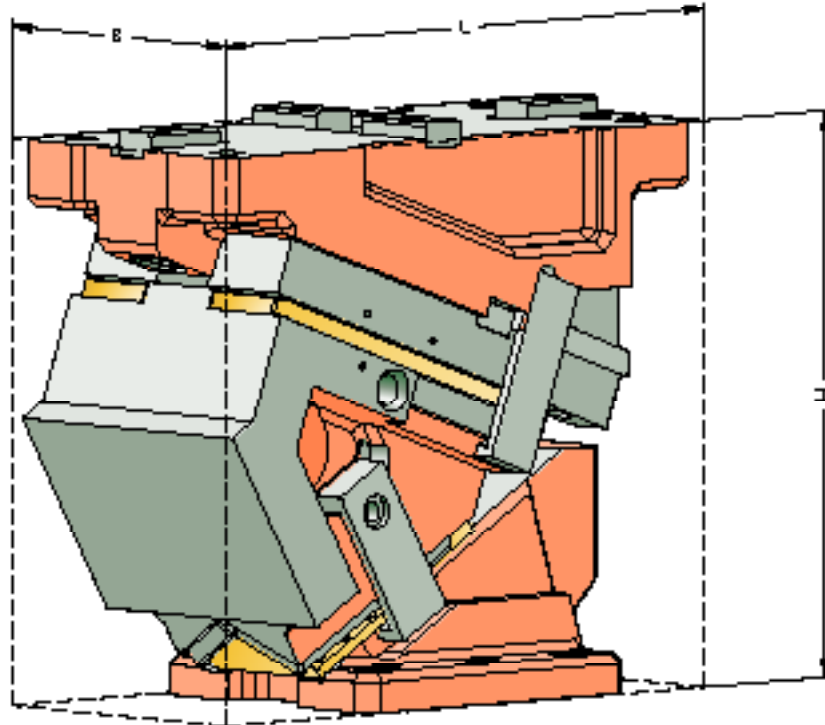

AERIAL ECO LINE

2016.207.□□.016.

SIZE TABLE

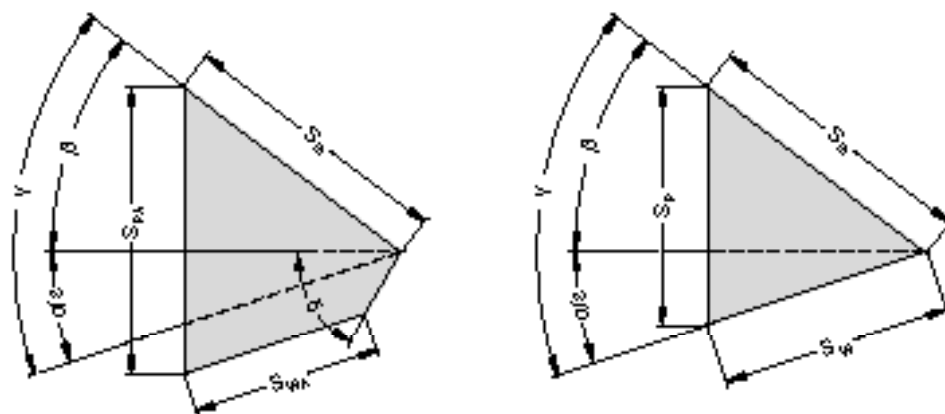

Order number	L [mm]	B [mm]	H [mm]	H ₁ [mm]	H _W [mm]	L ₁ [mm]	L ₂ [mm]	L ₃ [mm]	L ₄ [mm]	L ₅ [mm]	D [mm]	α [°]	β [°]	S _W * [mm]	S _{WA} * [mm]	S _S [mm]	S _P * [mm]
2016.207.00.016.032.21	340	165	300	107	120	255.8	340	182.8	190	10	335.8	0	50	-	24.5	50	48.2
2016.207.05.016.035.21	340	165	300	103.9	120	254.7	340	196.7	190	10	342.8	5	45	-	22.3	50	53.5
2016.207.10.016.038.21	340	165	300	107	120	256.8	340	205.8	190	10	351.4	10	40	-	24.8	50	52.7
2016.207.15.016.042.21	340	165	300	111.4	120	249.9	340	217.9	190	10	350.2	15	35	-	29.3	50	52.0
2016.207.20.016.046.21	340	165	300	112	120	254.1	340	226.1	190	10	357.1	20	30	-	34.0	50	52.2
2016.207.25.016.050.21	340	165	300	113.9	120	256.2	340	198.2	190	10	360.3	25	25	-	38.8	50	52.7
2016.207.30.016.054.21	340	165	300	116.9	120	260	340	212	190	10	363.6	30	20	54.3	-	50	44.2
2016.207.35.016.059.21	340	165	300	121.2	120	258.5	340	225.5	190	10	361.3	35	15	59.0	-	50	46.8
2016.207.40.016.064.21	350	165	300	126.6	120	253.6	340	238.6	190	10	355.7	40	10	64.3	-	50	50.0
2016.207.45.016.070.21	365	165	300	133.2	120	251.2	340	251.2	190	10	351.8	45	5	70.4	-	50	54.2
2016.207.50.016.077.21	355	165	300	140.8	120	248.2	340	263.2	190	10	347.4	50	0	77.8	-	50	59.6
2016.207.55.016.087.21	372	165	300	139	120	258.9	340	290.9	190	10	342.4	55	0	87.2	-	50	71.4
2016.207.60.016.100.21	385	165	300	145.5	120	261.6	340	306.6	190	15	336.8	60	0	100.0	-	50	86.6

* Values rounded

Mounting cam base:

Hexagon socket head cap screws DIN EN ISO 4762
Dowel pins DIN EN ISO 8735

4x M16 / Strength class min. 8.8
2x ø16

Mounting cam driver:

Hexagon socket head cap screws DIN EN ISO 4762
Dowel pins DIN EN ISO 8735

4x M16 / Strength class min. 8.8
2x ø16

AERIAL ECO LINE
2016.207.□□.016.
 EXPLODED VIEW

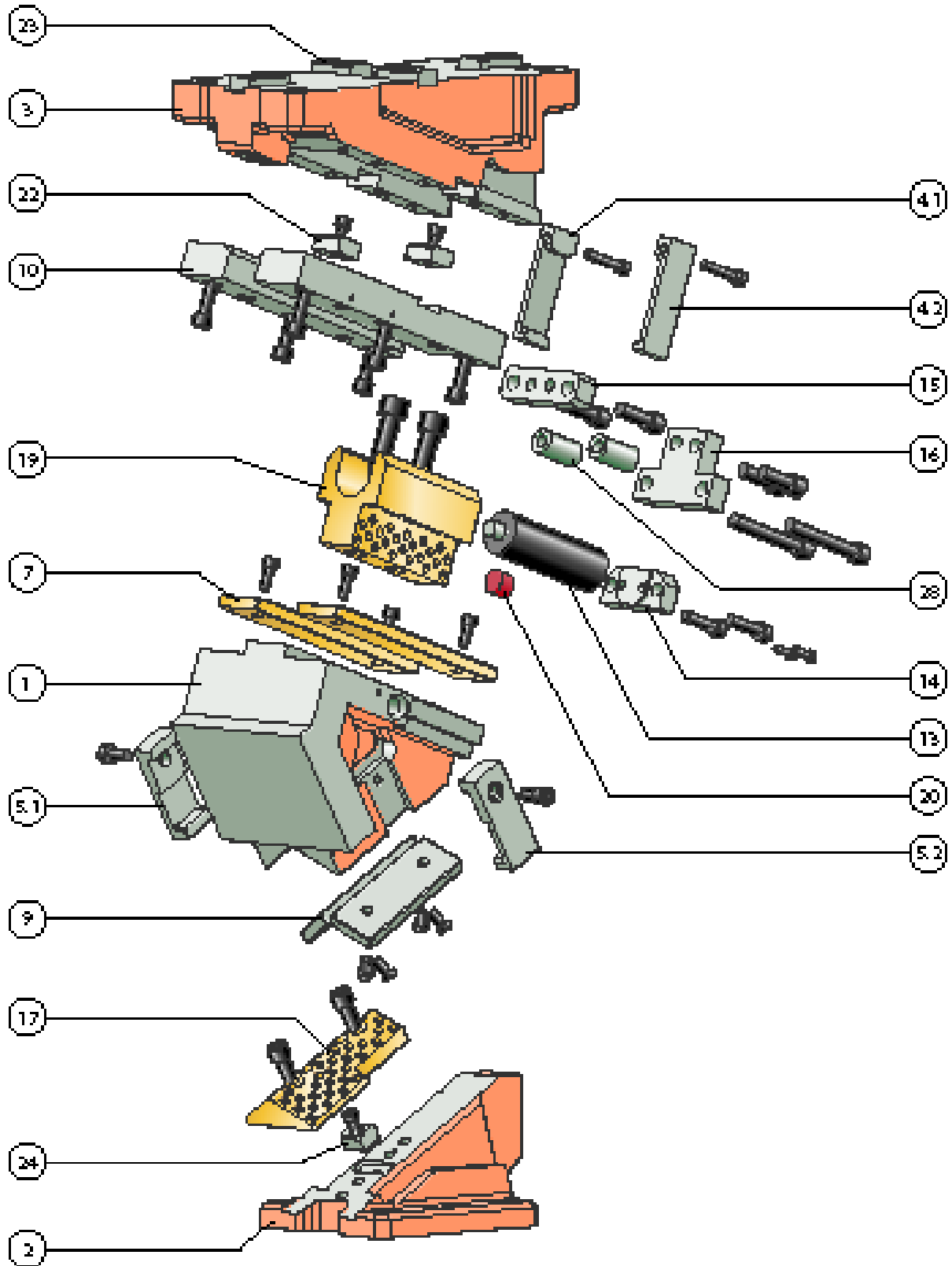

AERIAL ECO LINE

2016.207.□□.016.

PARTS LIST

Position	Piece	Designation	Material	spare part
1	1	Body		
2	1	Driver		
3	1	Base		
4.1	1	Clamp, left		x
4.2	1	Clamp, right		x
5.1	1	Positive return, left		x
5.2	1	Positive return, right		x
6				
7	2	Sliding plate	Bronze with solid lubricant	x
8				
9	2	Sliding plate	Steel	x
10	2	Sliding plate	Steel	x
11				
12				
13	1	Gas spring		x
14	1	Stop plate		x
15	1	Stop piece		x
16	1	Lockout system		x
17	1	Slide pad	Bronze with solid lubricant	x
18				
19	1	Centre guide	Bronze with solid lubricant	x
20	1	Damper		x
21				
22	2	Feather key		x
23	4	Feather key		x
24	1	Feather key		x
25				
26				
27				
28	2	Spacer		x

For inquiries or when ordering spare parts (x), we require the following data:

- Cam unit order no.
- Cam unit serial no.
- Item number / Designation / Spare part

AERIAL ECO LINE

2016.207.□□.016.

SYSTEM AND SURROUNDING FORCES

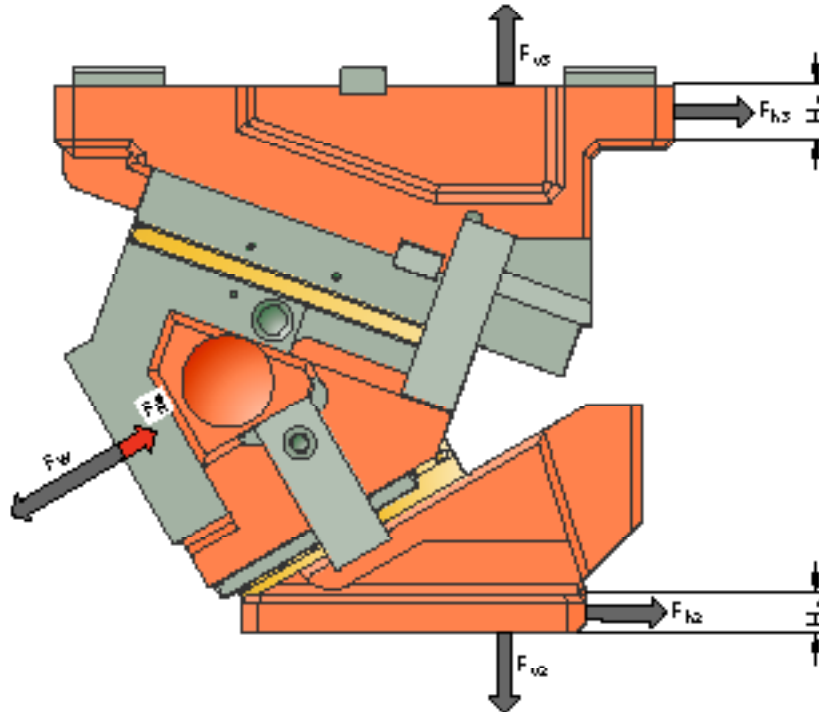

Order number	α [°]	F_W [kN]	F_R^* [kN]	F_{h2} [kN]	F_{v2} [kN]	F_{h3} [kN]	F_{v3} [kN]	H_2 [mm]	H_3 [mm]
2016.207.00.016.032.21	0	294	3.9	0	247	294	247	23	30
2016.207.05.016.035.21	5	294	4.0	22	246	271	271	23	30
2016.207.10.016.038.21	10	294	4.0	43	243	247	294	28	30
2016.207.15.016.042.21	15	294	4.0	64	238	220	314	30	30
2016.207.20.016.046.21	20	294	4.0	84	232	192	332	30	30
2016.207.25.016.050.21	25	294	4.0	104	224	162	348	21	30
2016.207.30.016.054.21	30	294	4.0	123	214	131	361	21	30
2016.207.35.016.059.21	35	294	4.0	141	202	99	371	21	30
2016.207.40.016.064.21	40	294	3.9	159	189	67	378	21	30
2016.207.45.016.070.21	45	294	3.9	174	174	33	382	21	30
2016.207.50.016.077.21	50	294	3.9	189	159	0	384	116	30
2016.207.55.016.087.21	55	294	4.3	169	118	0	359	110	30
2016.207.60.016.100.21	60	294	4.8	147	85	0	339	115	30

* Retraction force values correspond to the spring-generated retraction force at the working point

The forces F_{h2} , F_{v2} as well as F_{h3} , F_{v3} act on the tool environment at maximum working force F_W .



AERIAL ECO LINE
2016.207.□□.020.

AERIAL ECO LINE 2016.207.□□.020.

Working width: 200 mm
Performance class: 350 kN

AERIAL ECO LINE
2016.207.□□.020.
 SIZE TABLE

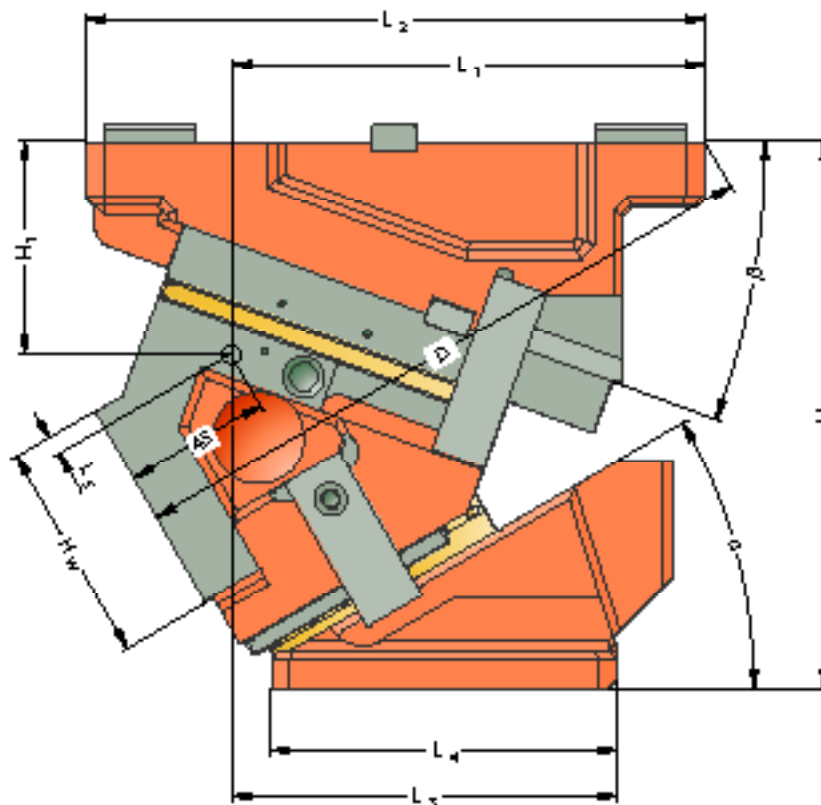
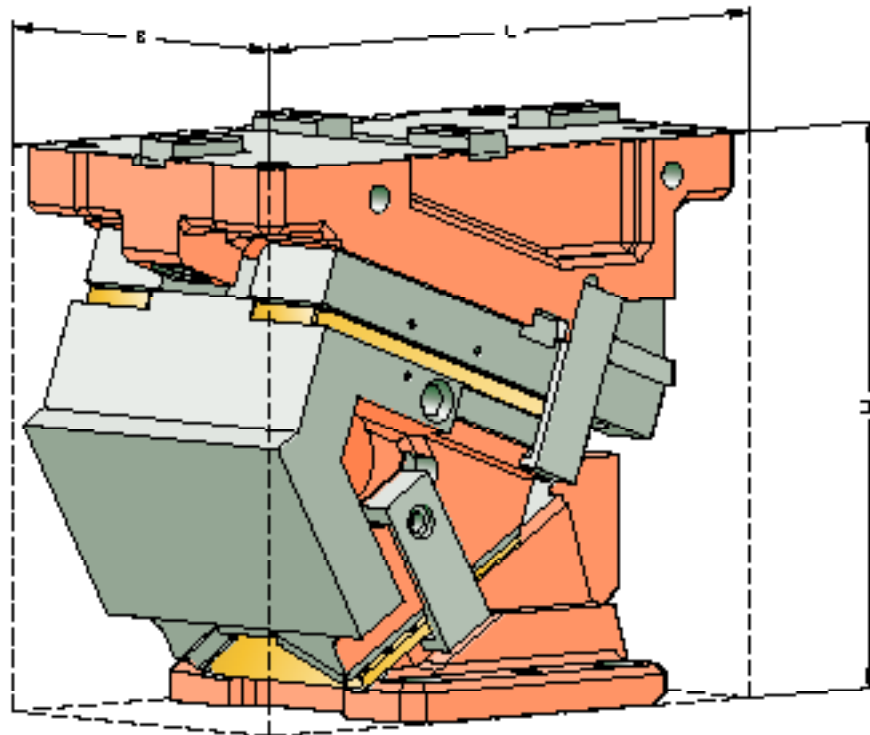

AERIAL ECO LINE

2016.207.□□.020.

SIZE TABLE

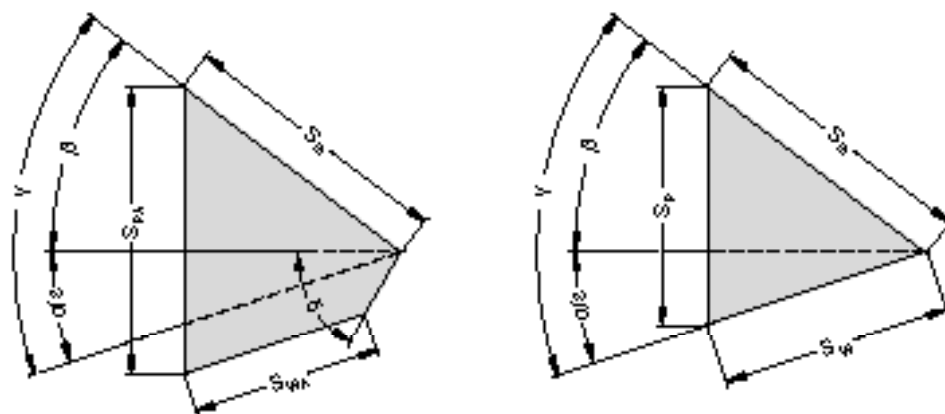

Order number	L [mm]	B [mm]	H [mm]	H ₁ [mm]	H _W [mm]	L ₁ [mm]	L ₂ [mm]	L ₃ [mm]	L ₄ [mm]	L ₅ [mm]	D [mm]	α [°]	β [°]	S _W * [mm]	S _{WA} * [mm]	S _S [mm]	S _P * [mm]
2016.207.00.020.032.21	340	200	300	101	120	290.8	340	217.8	190	4	335.8	0	50	-	24.5	50	48.2
2016.207.05.020.035.21	340	200	300	101	120	290.1	340	232.1	190	4	342.8	5	45	-	22.3	50	53.5
2016.207.10.020.038.21	340	200	300	107.2	120	292.3	340	241.3	190	4	351.4	10	40	-	24.8	50	52.7
2016.207.15.020.042.21	340	200	300	114.7	120	285.3	340	250.3	190	4	350.2	15	35	-	29.3	50	52.0
2016.207.20.020.046.21	340	200	300	118.4	120	289	340	261	190	4	357.1	20	30	-	34.0	50	52.2
2016.207.25.020.050.21	340	200	300	123.2	120	290.4	340	232.4	190	4	360.3	25	25	-	38.8	50	52.7
2016.207.30.020.054.21	340	200	300	129.4	120	293.3	340	245.3	190	4	363.6	30	20	54.3	-	50	44.2
2016.207.35.020.059.21	340	200	300	136.4	120	290.6	340	257.6	190	4	361.3	35	15	59.0	-	50	46.8
2016.207.40.020.064.21	350	200	300	144.5	120	284.3	340	269.3	190	4	355.7	40	10	64.3	-	50	50.0
2016.207.45.020.070.21	365	200	300	153.7	120	280.2	340	280.2	190	4	351.8	45	5	70.4	-	50	54.2
2016.207.50.020.077.21	355	200	300	163.7	120	275.3	340	290.3	190	4	347.4	50	0	77.8	-	50	59.6
2016.207.55.020.087.21	372	200	300	170	120	275.7	340	307.7	190	6	342.4	55	0	87.2	-	50	71.4
2016.207.60.020.100.21	385	200	300	180.3	120	271.3	340	316.3	190	6	336.8	60	0	100.0	-	50	86.6

* Values rounded

Mounting cam base:

Hexagon socket head cap screws DIN EN ISO 4762
Dowel pins DIN EN ISO 8735

4x M16 / Strength class min. 8.8
2x ø16

Mounting cam driver:

Hexagon socket head cap screws DIN EN ISO 4762
Dowel pins DIN EN ISO 8735

4x M16 / Strength class min. 8.8
2x ø16

AERIAL ECO LINE
2016.207.□□.020.
 EXPLODED VIEW

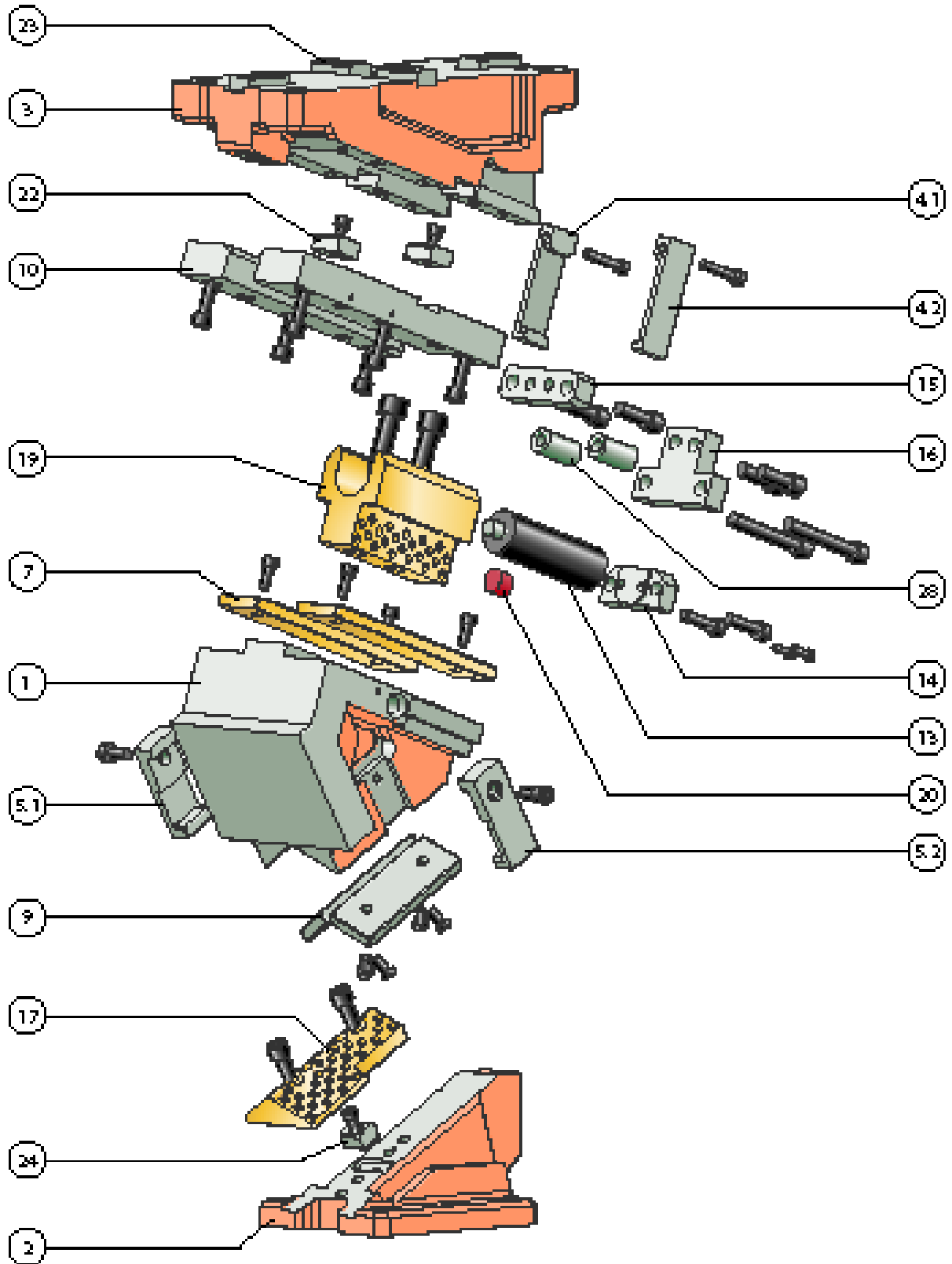

AERIAL ECO LINE

2016.207.□□.020.

PARTS LIST

Position	Piece	Designation	Material	spare part
1	1	Body		
2	1	Driver		
3	1	Base		
4.1	1	Clamp, left		x
4.2	1	Clamp, right		x
5.1	1	Positive return, left		x
5.2	1	Positive return, right		x
6				
7	2	Sliding plate	Bronze with solid lubricant	x
8				
9	2	Sliding plate	Steel	x
10	2	Sliding plate	Steel	x
11				
12				
13	1	Gas spring		x
14	1	Stop plate		x
15	1	Stop piece		x
16	1	Lockout system		x
17	1	Slide pad	Bronze with solid lubricant	x
18				
19	1	Centre guide	Bronze with solid lubricant	x
20	1	Damper		x
21				
22	2	Feather key		x
23	4	Feather key		x
24	1	Feather key		x
25				
26				
27				
28	2	Spacer		x

For inquiries or when ordering spare parts (x), we require the following data:

- Cam unit order no.
- Cam unit serial no.
- Item number / Designation / Spare part

AERIAL ECO LINE

2016.207.□□.020.

SYSTEM AND SURROUNDING FORCES

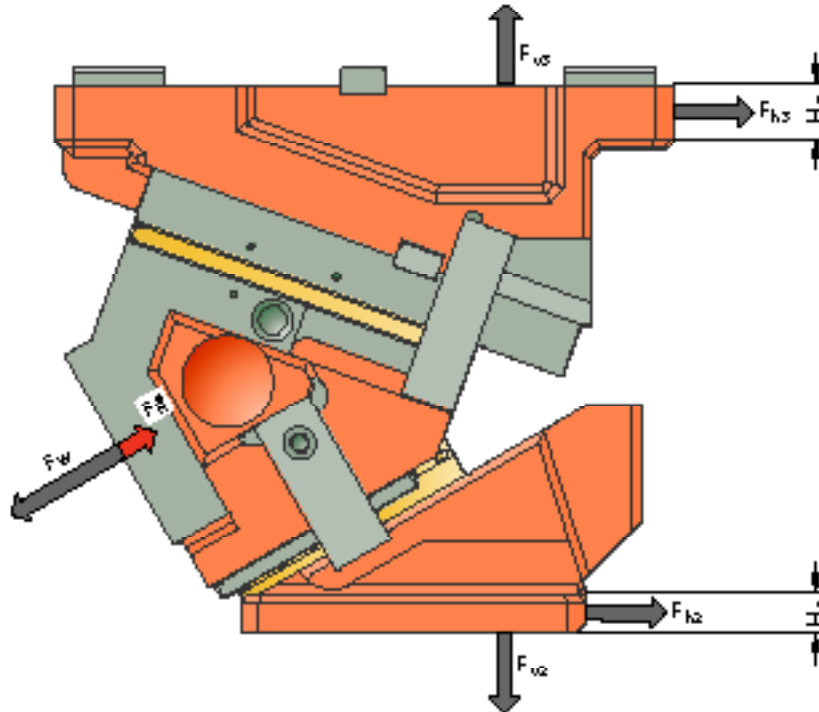

Order number	α [°]	F_W [kN]	F_R^* [kN]	F_{h2} [kN]	F_{v2} [kN]	F_{h3} [kN]	F_{v3} [kN]	H_2 [mm]	H_3 [mm]
2016.207.00.020.032.21	0	353	8.5	0	296	353	296	15	30
2016.207.05.020.035.21	5	353	8.5	26	295	326	326	23	30
2016.207.10.020.038.21	10	353	8.6	51	292	296	353	28	30
2016.207.15.020.042.21	15	353	8.6	77	286	264	377	30	30
2016.207.20.020.046.21	20	353	8.6	101	278	230	399	60	30
2016.207.25.020.050.21	25	353	8.6	125	268	195	418	21	30
2016.207.30.020.054.21	30	353	8.6	148	257	158	433	21	30
2016.207.35.020.059.21	35	353	8.6	170	243	119	445	21	30
2016.207.40.020.064.21	40	353	8.6	190	227	80	454	21	30
2016.207.45.020.070.21	45	353	8.6	209	209	40	459	21	30
2016.207.50.020.077.21	50	353	8.6	227	190	0	461	116	30
2016.207.55.020.087.21	55	353	9.5	202	142	0	431	110	30
2016.207.60.020.100.21	60	353	10.7	177	102	0	408	115	30

* Retraction force values correspond to the spring-generated retraction force at the working point

The forces F_{h2} , F_{v2} as well as F_{h3} , F_{v3} act on the tool environment at maximum working force F_W .



**AERIAL
ECO LINE
2016.207.□□.030.**

Working width: 300 mm
Performance class: 450 kN

AERIAL ECO LINE
2016.207.□□.030.
 SIZE TABLE

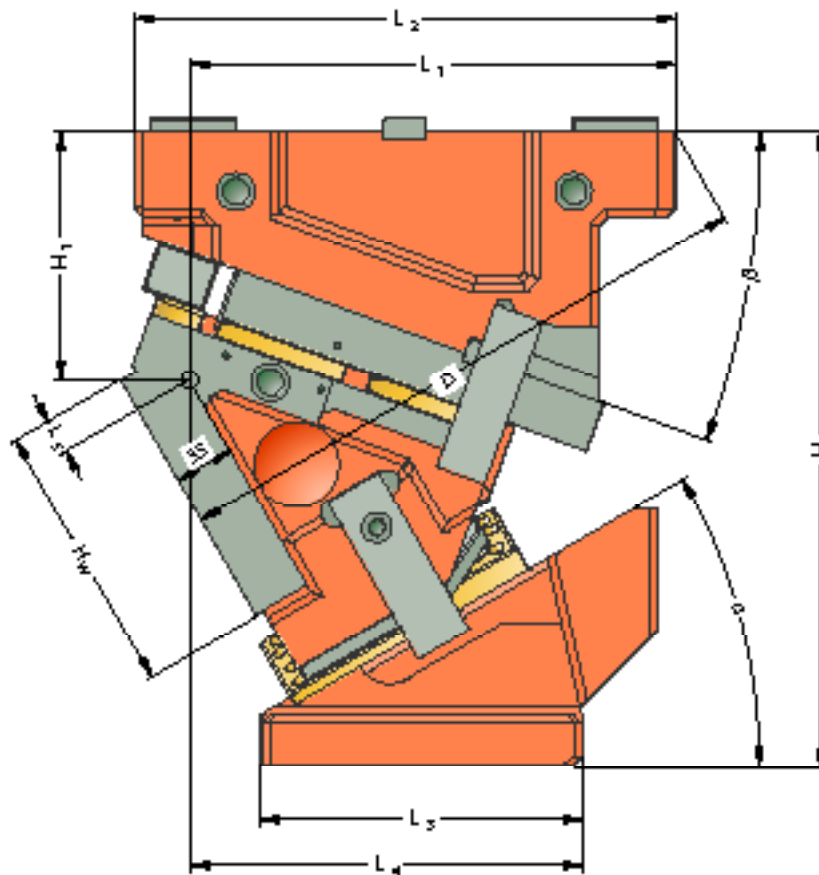
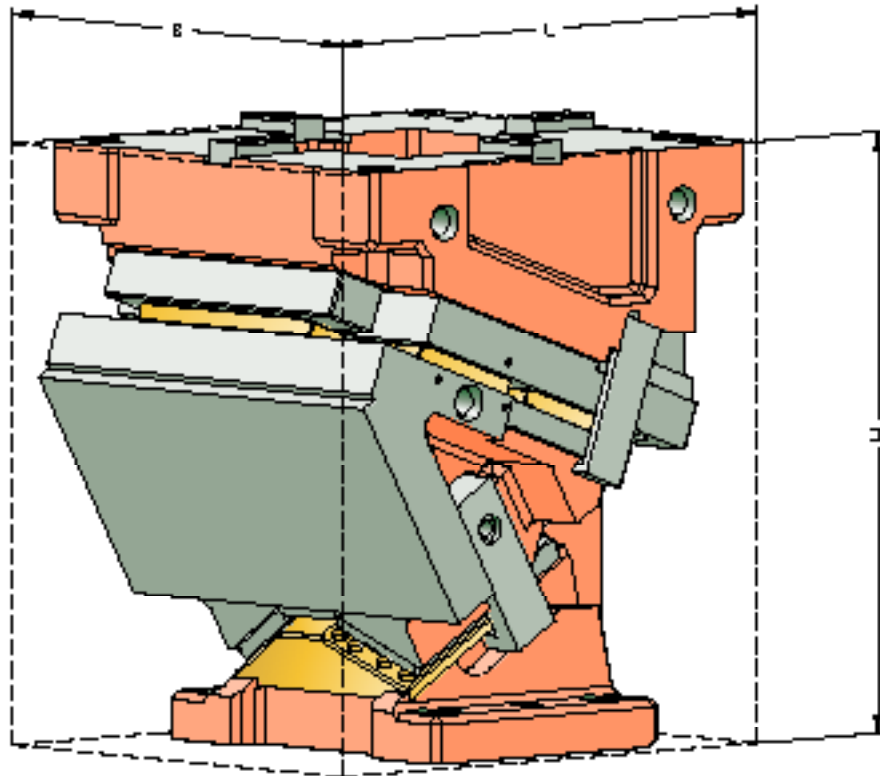

AERIAL ECO LINE

2016.207.□□.030.

SIZE TABLE

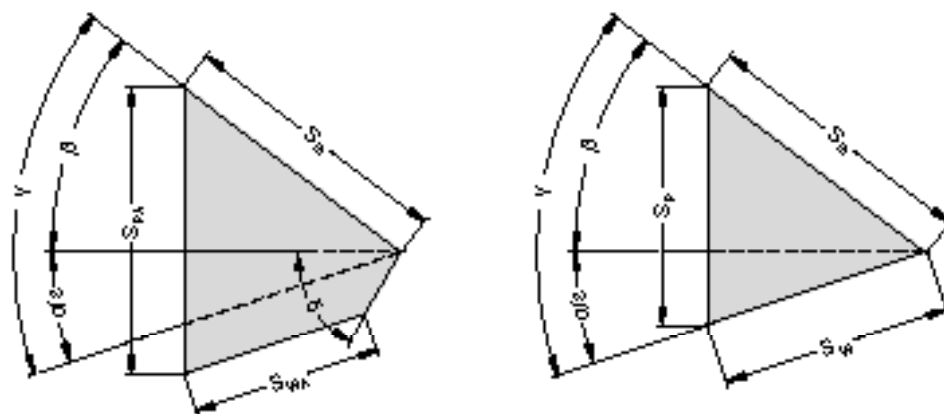

Order number	L [mm]	B [mm]	H [mm]	H ₁ [mm]	H _W [mm]	L ₁ [mm]	L ₂ [mm]	L ₃ [mm]	L ₄ [mm]	L ₅ [mm]	D [mm]	α [°]	β [°]	S _W * [mm]	S _{WA} * [mm]	S _S [mm]	S _P * [mm]
2016.207.00.030.038.21	328	300	375	118	160	278	320	195	190	20	313.0	0	50	-	29.5	60	59.3
2016.207.05.030.042.21	320	300	375	121.1	160	280.5	320	210.5	190	20	325.0	5	45	-	18.9	60	63.9
2016.207.10.030.046.21	324.1	300	375	125.5	160	286.2	320	226.2	190	20	338.6	10	40	-	24.1	60	63.4
2016.207.15.030.050.21	325.8	300	375	131.3	160	286.9	320	241.9	190	20	346.1	15	35	-	29.1	60	63.8
2016.207.20.030.055.21	327	300	375	138.4	160	287.4	320	202.4	190	20	352.4	20	30	-	34.7	60	63.7
2016.207.25.030.060.21	334.7	300	375	142	160	294.5	320	219.5	190	20	362.0	25	25	-	40.3	60	64.8
2016.207.30.030.065.21	327.8	300	375	146.7	160	287.5	320	232.5	190	20	357.4	30	20	65.1	-	60	53.1
2016.207.35.030.070.21	345.5	300	375	155.5	160	294.4	320	249.4	190	20	365.3	35	15	70.8	-	60	56.1
2016.207.40.030.077.21	303.5	300	375	160.1	160	285.8	320	260.8	190	20	356.9	40	10	77.1	-	60	60.0
2016.207.45.030.084.21	349.7	300	375	168.6	160	285.9	320	278.9	190	20	356.4	45	5	84.5	-	60	65.0
2016.207.50.030.079.21	355	300	375	186.1	160	265	320	300	190	25	347.9	50	0	79.3	-	51	60.8
2016.207.55.030.088.21	405	300	375	210.5	160	252.5	320	337.5	190	10	347.2	55	0	88.9	-	51	72.8
2016.207.60.030.102.21	405	300	375	224.7	160	262.8	320	347.8	190	10	356.0	60	0	102.0	-	51	88.3

* Values rounded

Mounting cam base:

Hexagon socket head cap screws DIN EN ISO 4762
Dowel pins DIN EN ISO 8735

4x M20 / Strength class min. 8.8
2x ø16

Mounting cam driver:

Hexagon socket head cap screws DIN EN ISO 4762
Dowel pins DIN EN ISO 8735

4x M20 / Strength class min. 8.8
2x ø20

AERIAL ECO LINE
2016.207.□□.030.
 EXPLODED VIEW

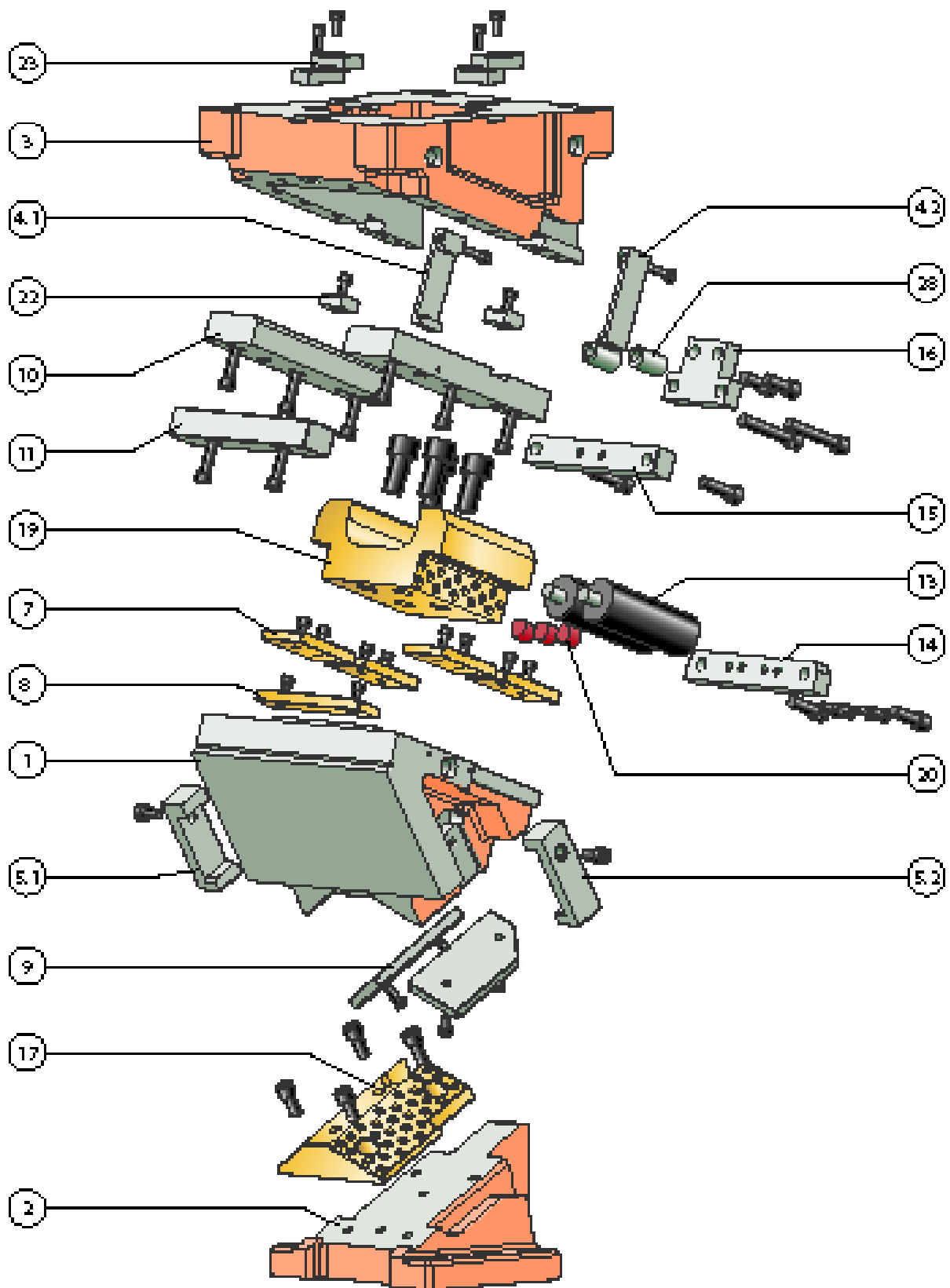

AERIAL ECO LINE

2016.207.□□.030.

PARTS LIST

Position	Piece	Designation	Material	spare part
1	1	Body		
2	1	Driver		
3	1	Base		
4.1	1	Clamp, left		x
4.2	1	Clamp, right		x
5.1	1	Positive return, left		x
5.2	1	Positive return, right		x
6				
7	4	Sliding plate	Bronze with solid lubricant	x
8	1	Sliding plate	Bronze with solid lubricant	x
9	2	Sliding plate	Steel	x
10	2	Sliding plate	Steel	x
11	1	Sliding plate	Steel	x
12				
13	2	Gas spring		x
14	1	Stop plate		x
15	1	Stop piece		x
16	1	Lockout system		x
17	1	Slide pad	Bronze with solid lubricant	x
18				
19	1	Centre guide	Bronze with solid lubricant	x
20	3	Damper		x
21				x
22	2	Feather key		x
23	4	Feather key		x
24				
25				
26				
27				
28	2	Spacer		x

For inquiries or when ordering spare parts (x), we require the following data:

- Cam unit order no.
- Cam unit serial no.
- Item number / Designation / Spare part

AERIAL ECO LINE

2016.207.□□.030.

SYSTEM AND SURROUNDING FORCES

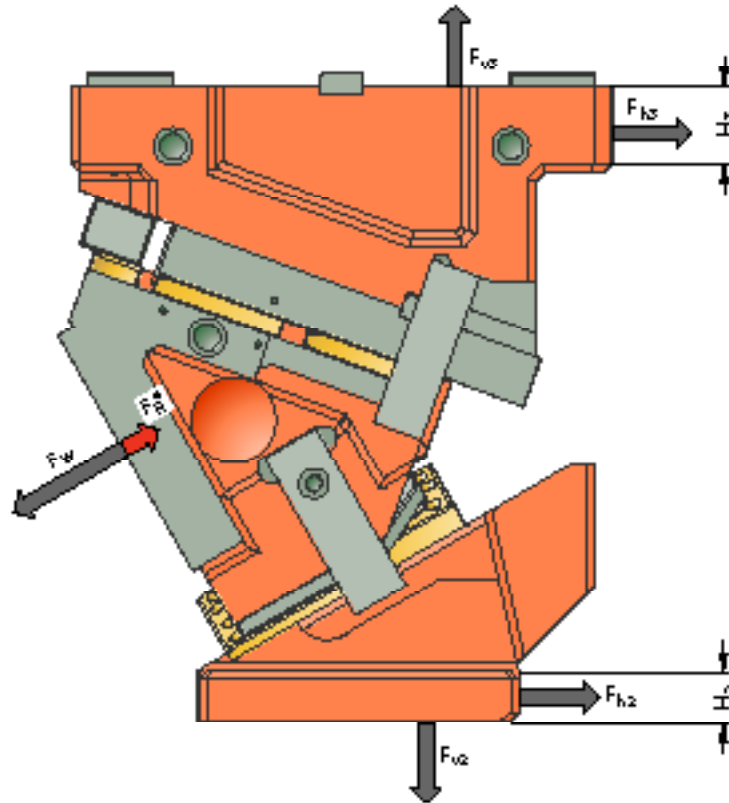

Order number	α [°]	F_W [kN]	F_R^* [kN]	F_{h2} [kN]	F_{v2} [kN]	F_{h3} [kN]	F_{v3} [kN]	H_2 [mm]	H_3 [mm]
2016.207.00.030.038.21	0	451	16.9	0	378	451	378	30	45
2016.207.05.030.042.21	5	451	17.0	33	377	416	416	35	45
2016.207.10.030.046.21	10	451	17.0	66	373	378	451	40	45
2016.207.15.030.050.21	15	451	17.1	98	366	338	482	55	45
2016.207.20.030.055.21	20	451	17.1	129	356	294	510	25	45
2016.207.25.030.060.21	25	451	17.1	160	343	249	534	25	45
2016.207.30.030.065.21	30	451	17.1	189	328	201	553	30	45
2016.207.35.030.070.21	35	451	17.1	217	310	152	569	30	45
2016.207.40.030.077.21	40	451	17.1	243	290	102	580	30	45
2016.207.45.030.084.21	45	451	17.1	268	268	51	586	30	45
2016.207.50.030.079.21	50	451	16.3	290	243	0	589	170	45
2016.207.55.030.088.21	55	451	17.9	259	181	0	551	170	45
2016.207.60.030.102.21	60	451	20.1	226	130	0	521	150	45

* Retraction force values correspond to the spring-generated retraction force at the working point

The forces F_{h2} , F_{v2} as well as F_{h3} , F_{v3} act on the tool environment at maximum working force F_W .



**AERIAL
ECO LINE
2016.207.□□.040.**

Working width: 400 mm
Performance class: 450 kN

AERIAL ECO LINE
2016.207.□□.040.
 SIZE TABLE

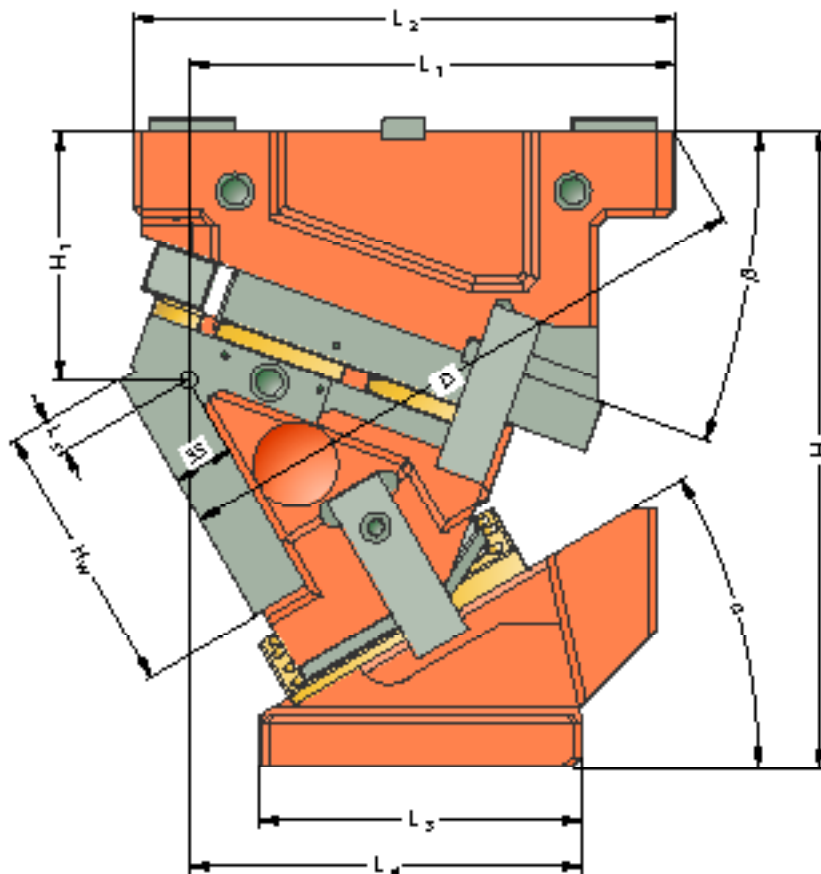
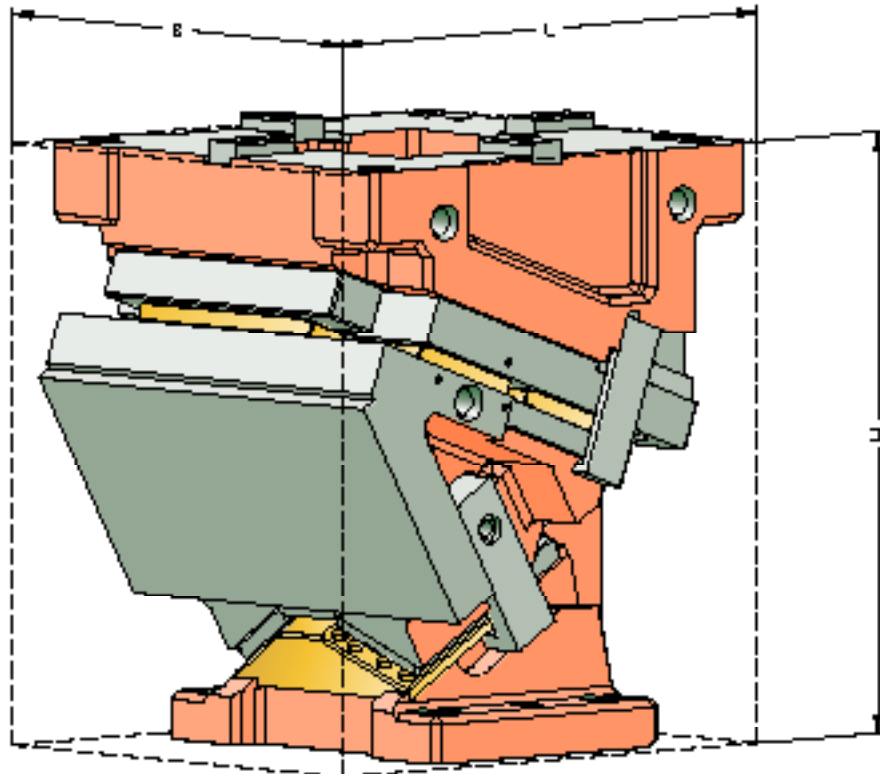

AERIAL ECO LINE

2016.207.□□.040.

SIZE TABLE

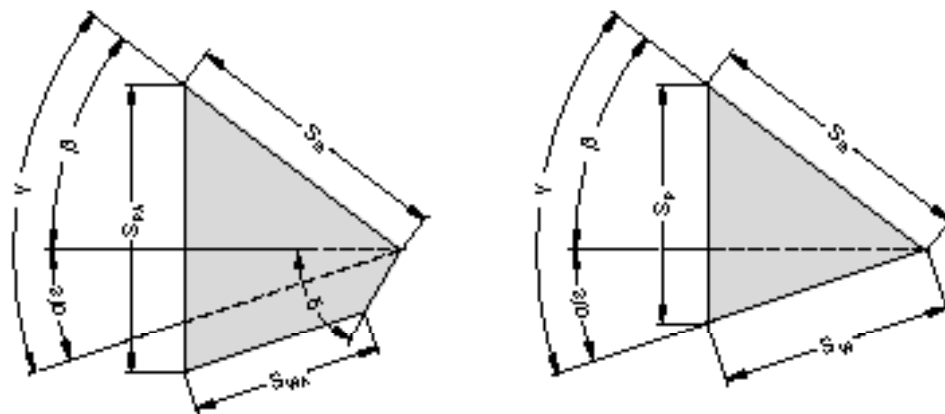

Order number	L [mm]	B [mm]	H [mm]	H ₁ [mm]	H _W [mm]	L ₁ [mm]	L ₂ [mm]	L ₃ [mm]	L ₄ [mm]	L ₅ [mm]	D [mm]	α [°]	β [°]	S _W * [mm]	S _{WA} * [mm]	S _S [mm]	S _P * [mm]
2016.207.00.040.038.21	328	400	375	118	160	278	320	195	190	20	313.0	0	50	-	29.5	60	59.3
2016.207.05.040.042.21	320	400	375	121.1	160	280.5	320	210.5	190	20	325.0	5	45	-	18.9	60	63.9
2016.207.10.040.046.21	324.1	400	375	125.5	160	286.2	320	226.2	190	20	338.6	10	40	-	24.1	60	63.4
2016.207.15.040.050.21	325.8	400	375	131.3	160	286.9	320	241.9	190	20	346.1	15	35	-	29.1	60	63.8
2016.207.20.040.055.21	327	400	375	138.4	160	287.4	320	202.4	190	20	352.4	20	30	-	34.7	60	63.7
2016.207.25.040.060.21	334.7	400	375	142	160	294.5	320	219.5	190	20	362.0	25	25	-	40.3	60	64.8
2016.207.30.040.065.21	327.8	400	375	146.7	160	287.5	320	232.5	190	20	357.4	30	20	65.1	-	60	53.1
2016.207.35.040.070.21	345.5	400	375	155.5	160	294.4	320	249.4	190	20	365.3	35	15	70.8	-	60	56.1
2016.207.40.040.077.21	303.5	400	375	160.1	160	285.8	320	260.8	190	20	356.9	40	10	77.1	-	60	60.0
2016.207.45.040.084.21	349.7	400	375	168.6	160	285.9	320	278.9	190	20	356.4	45	5	84.5	-	60	65.0
2016.207.50.040.079.21	355	400	375	186.1	160	265	320	300	190	25	347.9	50	0	79.3	-	51	60.8
2016.207.55.040.088.21	405	400	375	210.5	160	252.5	320	337.5	190	10	347.2	55	0	88.9	-	51	72.8
2016.207.60.040.102.21	405	400	375	224.7	160	262.8	320	347.8	190	10	356.0	60	0	102.0	-	51	88.3

* Values rounded

Mounting cam base:

Hexagon socket head cap screws DIN EN ISO 4762
Dowel pins DIN EN ISO 8735

4x M20 / Strength class min. 8.8
2x ø16

Mounting cam driver:

Hexagon socket head cap screws DIN EN ISO 4762
Dowel pins DIN EN ISO 8735

4x M20 / Strength class min. 8.8
2x ø20

AERIAL ECO LINE
2016.207.□□.040.
 EXPLODED VIEW

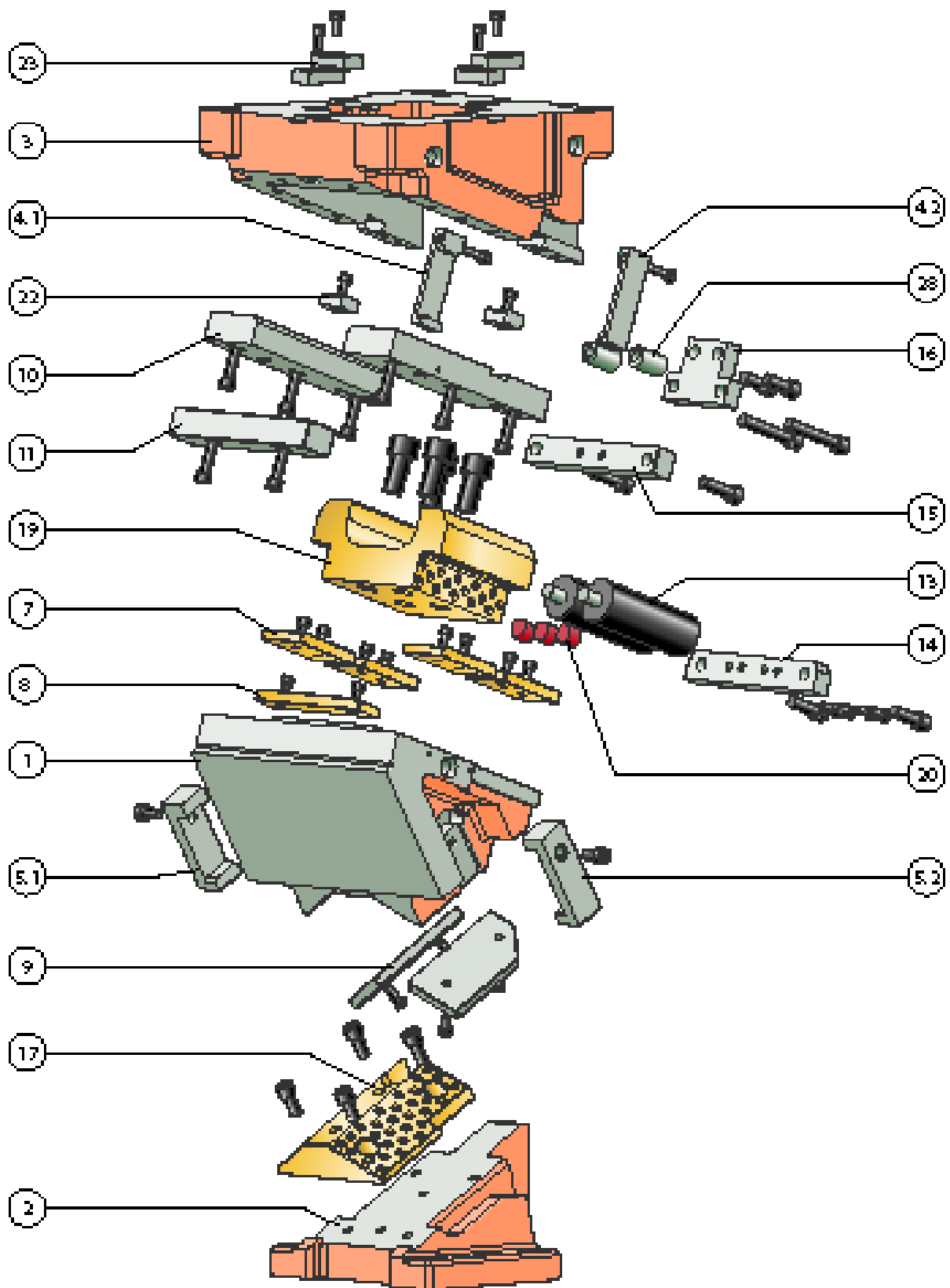

AERIAL ECO LINE

2016.207.□□.040.

PARTS LIST

Position	Piece	Designation	Material	spare part
1	1	Body		
2	1	Driver		
3	1	Base		
4.1	1	Clamp, left		x
4.2	1	Clamp, right		x
5.1	1	Positive return, left		x
5.2	1	Positive return, right		x
6				
7	4	Sliding plate	Bronze with solid lubricant	x
8	1	Sliding plate	Bronze with solid lubricant	x
9	2	Sliding plate	Steel	x
10	2	Sliding plate	Steel	x
11	1	Sliding plate	Steel	x
12				
13	2	Gas spring		x
14	1	Stop plate		x
15	1	Stop piece		x
16	1	Lockout system		x
17	1	Slide pad	Bronze with solid lubricant	x
18				
19	1	Centre guide	Bronze with solid lubricant	x
20	3	Damper		x
21				x
22	2	Feather key		x
23	4	Feather key		x
24				
25				
26				
27				
28	2	Spacer		x

For inquiries or when ordering spare parts (x), we require the following data:

- Cam unit order no.
- Cam unit serial no.
- Item number / Designation / Spare part

AERIAL ECO LINE

2016.207.□□.040.

SYSTEM AND SURROUNDING FORCES

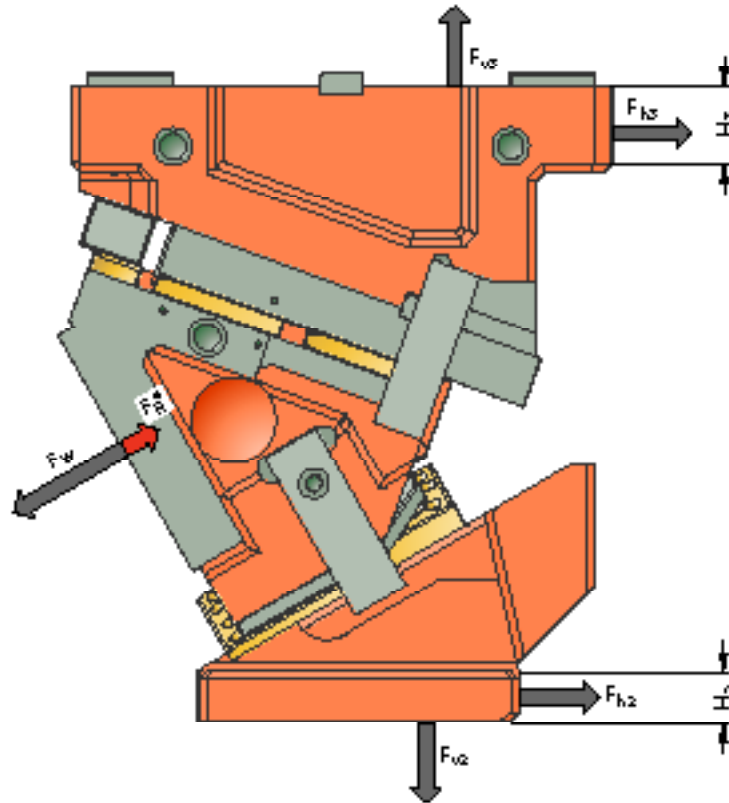

Order number	α [°]	F_W [kN]	F_{R^*} [kN]	F_{h2} [kN]	F_{v2} [kN]	F_{h3} [kN]	F_{v3} [kN]	H_2 [mm]	H_3 [mm]
2016.207.00.040.038.21	0	451	16.9	0	378	451	378	30	45
2016.207.05.040.042.21	5	451	17.0	33	377	416	416	35	45
2016.207.10.040.046.21	10	451	17.0	66	373	378	451	40	45
2016.207.15.040.050.21	15	451	17.1	98	366	338	482	55	45
2016.207.20.040.055.21	20	451	17.1	129	356	294	510	25	45
2016.207.25.040.060.21	25	451	17.1	160	343	249	534	25	45
2016.207.30.040.065.21	30	451	17.1	189	328	201	553	30	45
2016.207.35.040.070.21	35	451	17.1	217	310	152	569	30	45
2016.207.40.040.077.21	40	451	17.1	243	290	102	580	30	45
2016.207.45.040.084.21	45	451	17.1	268	268	51	586	30	45
2016.207.50.040.079.21	50	451	16.3	290	243	0	589	170	45
2016.207.55.040.088.21	55	451	17.9	259	181	0	551	170	45
2016.207.60.040.102.21	60	451	20.1	226	130	0	521	150	45

* Retraction force values correspond to the spring-generated retraction force at the working point

The forces F_{h2} , F_{v2} as well as F_{h3} , F_{v3} act on the tool environment at maximum working force F_W .

INTRODUCTION AND TABLE OF CONTENTS

ENGINEERING

2016.24. AERIAL FCC BAK

DAIMLER, VOLVO,
VOLKSWAGEN GROUP

2016.25. AERIAL FCC BAK

DAIMLER, VOLVO,
VOLKSWAGEN GROUP

2016.207. AERIAL ECO LINE

2016.208. AERIAL ECO LINE

CUSTOMER-SPECIFIC SERVICES

APPENDIX

EMERGENCY SITUATION / CONTACTS



**AERIAL
ECO LINE
2016.208.**

AERIAL ECO LINE 2016.208.

FIBRO ECO LINE cam units series 2016.208. extend the ECO LINE valve series up to a width of 1000 mm. When properly maintained, these cam units allow a high number of cycles with sufficient precision over the entire nominal lifetime.

The gas springs for the cam unit return stroke can be exchanged without dismounting the cam unit with sufficient free space in the tool.

FIBRO ECO LINE cam unit series 2016.208. are equipped with a roll pre-acceleration up to an angle of 40°.

The optional machining of the working surface per your specifications fulfil the requirements for typical toolmaking tolerances.

Design features:

- Double Prismatic guide against cam driver, flat guide against base.
- Sliding surfaces hardened steel / bronze with solid lubricant
- Gas springs

FIBRO ECO LINE cam units series 2016.208. are available in the widths from 500 to 1000 mm and in the angular variants 0° to 60° (gradation 5°).

Order number	Width [mm]	Performance class [kN]*	Page
2016.208.□□.050.□□□.21	500	300	263
2016.208.□□.060.□□□.21	600	300	269
2016.208.□□.070.□□□.21	700	475	275
2016.208.□□.080.□□□.21	800	475	281
2016.208.□□.090.□□□.21	900	625	287
2016.208.□□.100.□□□.21	1000	625	293

* For exact power values, please refer to the specifications of the respective cam unit type

Ordering example:

FIBRO ECO LINE cam unit, aerial, width 900 mm	=	2016.208.□□.090.□□□.21
Cam unit angle $\alpha = 20^\circ$	=	20.
Cam unit stroke according to flow diagram (no option)	=	055.
Order number	=	2016.208. 20. 090. 055. 21



**AERIAL
ECO LINE
2016.208.□□.050.**

Working width: 500 mm
Performance class: 300 kN

AERIAL ECO LINE
2016.208.□□.050.
 SIZE TABLE

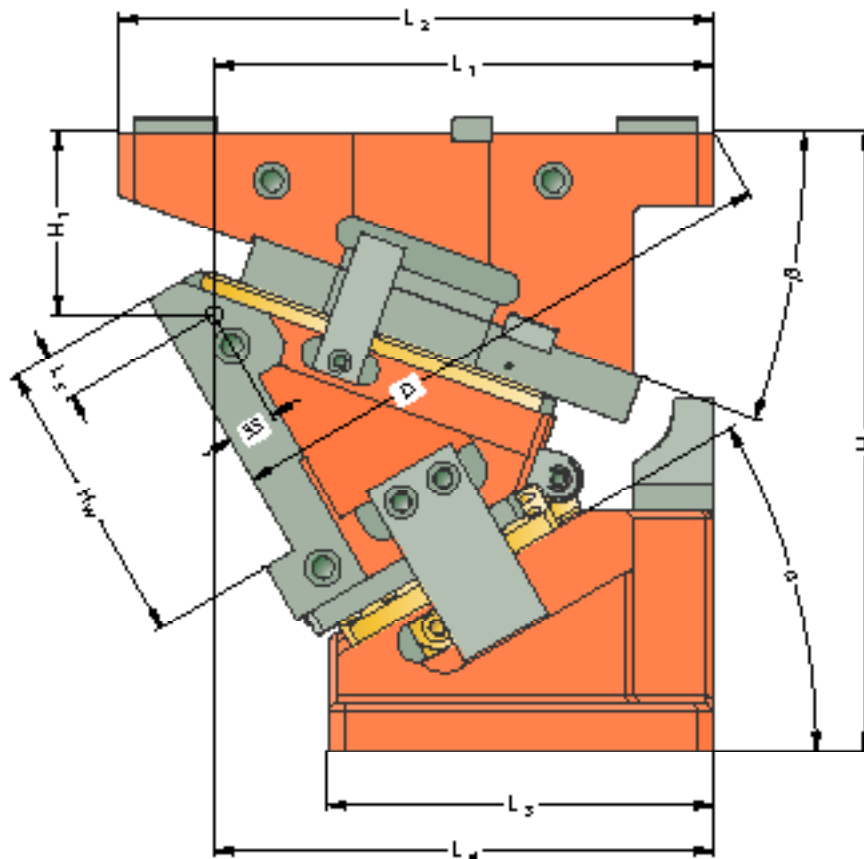
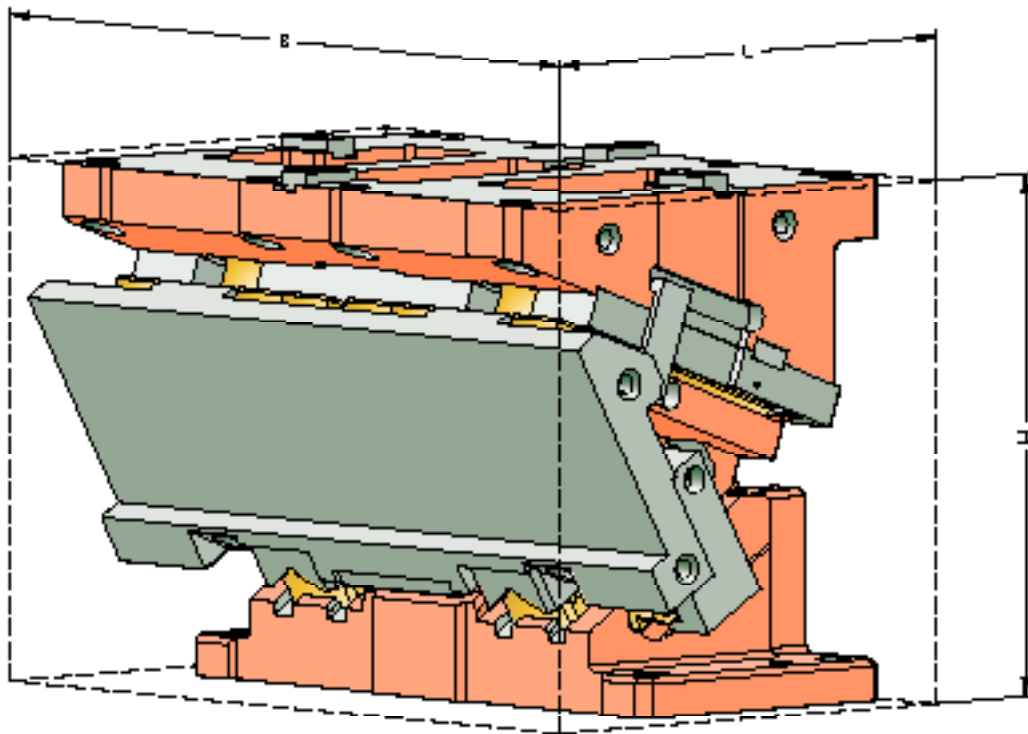

AERIAL ECO LINE

2016.208.□□.050.

SIZE TABLE

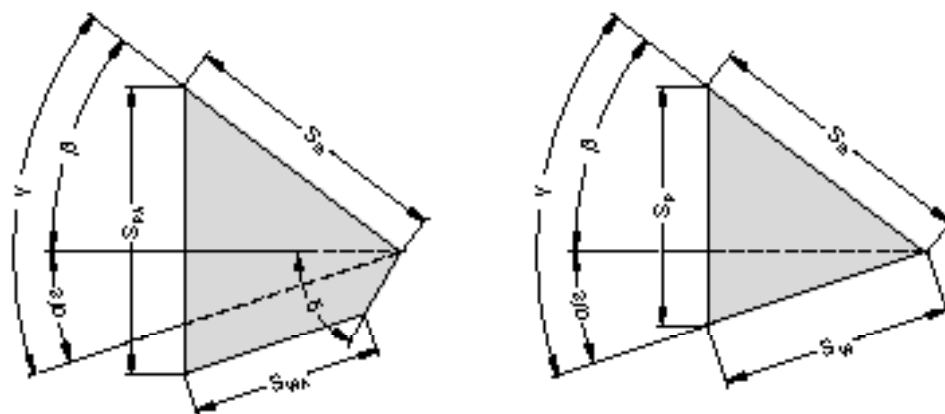

Order number	L	B	H	H ₁	H _w	L ₁	L ₂	L ₃	L ₄	L ₅	D	α	β	S _w *	S _{wA} *	S _s	S _p *	S _{pA} *
2016.208.	[mm]	[mm]	[mm]	[mm]	[mm]	[mm]	[mm]	[mm]	[mm]	[mm]	[mm]	[°]	[°]	[mm]	[mm]	[mm]	[mm]	[mm]
00.050.038.21	370	500	385	85	180	293	370	198	240	28	323	0	50	-	36.8	60	-	48.0
05.050.042.21	370	500	385	83.9	180	397.3	370	217.3	240	28	333.4	5	45	-	40.0	60	-	57.5
10.050.046.21	370	500	385	84.5	180	301.5	370	236.5	240	28	341.6	10	40	-	45.0	60	-	54.9
15.050.050.21	370	500	385	86.8	180	305.7	370	255.7	240	28	347.7	15	35	-	45.1	60	-	59.4
20.050.055.21	370	500	385	90.7	180	309.6	370	274.6	240	28	351.9	20	30	-	53.5	60	-	57.7
25.050.060.21	370	500	385	96.3	180	308	370	293	240	28	349.9	25	25	-	56.3	60	-	67.5
30.050.065.21	370	500	385	113.5	180	310.9	370	310.9	240	28	356	30	20	-	42.9	60	-	66.1
35.050.070.21	385	500	385	122.2	180	313.2	370	328.2	240	28	356.6	35	15	-	57.1	60	-	77.8
40.050.077.21	400	500	385	132.3	180	314.6	370	344.6	240	28	356	40	10	-	73.7	60	-	76.3
45.050.084.21	410	500	385	143.9	180	320	370	360	240	28	358	45	5	84.5	-	60	65.0	-
50.050.093.21	430	500	385	156.7	180	314.4	370	374.4	240	28	352.2	50	0	93.3	-	60	71.5	-
55.050.104.21	430	500	385	170.8	180	327.6	370	387.6	240	28	357.8	55	0	104.6	-	60	85.7	-
60.050.120.21	438.8	500	385	185.9	180	339.5	370	399.5	240	28	360.8	60	0	120.0	-	60	103.9	-

* Values rounded

Mounting cam base:

Hexagon socket head cap screws DIN EN ISO 4762
Dowel pins DIN EN ISO 8735

8x M20 / Strength class min. 8.8
2x ø16

Mounting cam driver:

Hexagon socket head cap screws DIN EN ISO 4762
Dowel pins DIN EN ISO 8735

4x M16 / Strength class min. 8.8
2x ø16

AERIAL ECO LINE
2016.208.□□.050.
 EXPLODED VIEW

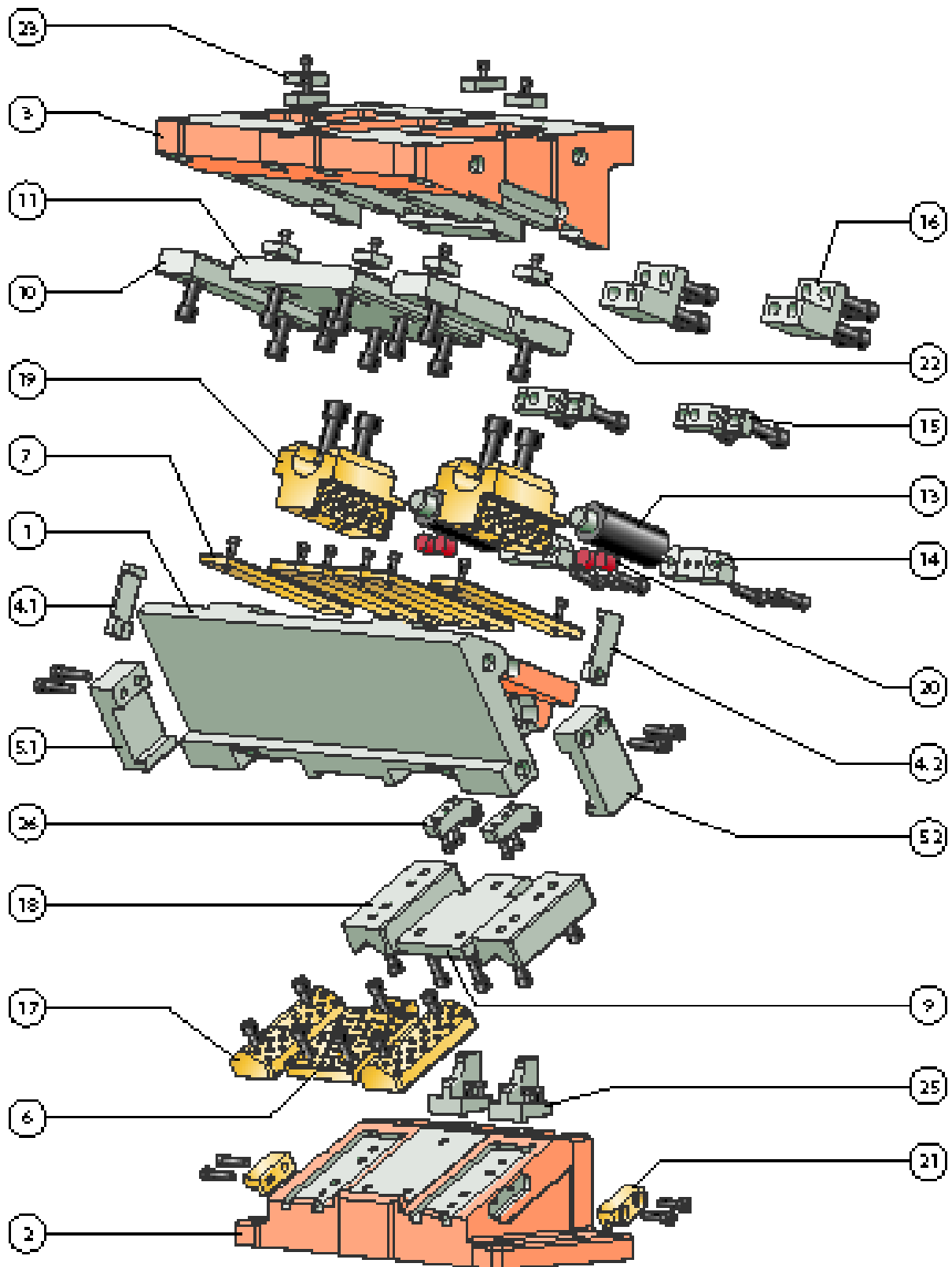

AERIAL ECO LINE

2016.208.□□.050.

PARTS LIST

Position	Piece	Designation	Material	spare part
1	1	Cam body		
2	1	Cam driver		
3	1	Cam base		
4.1	1	Clamp, left		x
4.2	1	Clamp, right		x
5.1	1	Positive return, left		x
5.2	1	Positive return, right		x
6	1	Sliding plate	Bronze with solid lubricant	x
7	6	Sliding plate	Bronze with solid lubricant	x
8				
9	1	Sliding plate	Steel	x
10	2	Sliding plate	Steel	x
11	1	Sliding plate	Steel	x
12				
13	2	Gas spring		x
14	2	Stop plate		x
15	2	Stop piece		x
16	2	Lockout system		x
17	2	Slide pad	Bronze with solid lubricant	x
18	2	Prismatic guide	Steel	x
19	2	Centre guide	Bronze with solid lubricant	x
20	4	Damper		x
21	2	Insert	Bronze with solid lubricant	x
22	4	Feather key		x
23	4	Feather key		x
24				
25*	2	Curve wedge		x
26*	2	Roller block		x
27				
28				

* up to and including 40° with pre-acceleration

For inquiries or when ordering spare parts (x), we require the following data:

- Cam unit order no.
- Cam unit serial number
- Item number / Designation / Spare part

AERIAL ECO LINE

2016.208.□□.050.

SYSTEM AND SURROUNDING FORCES

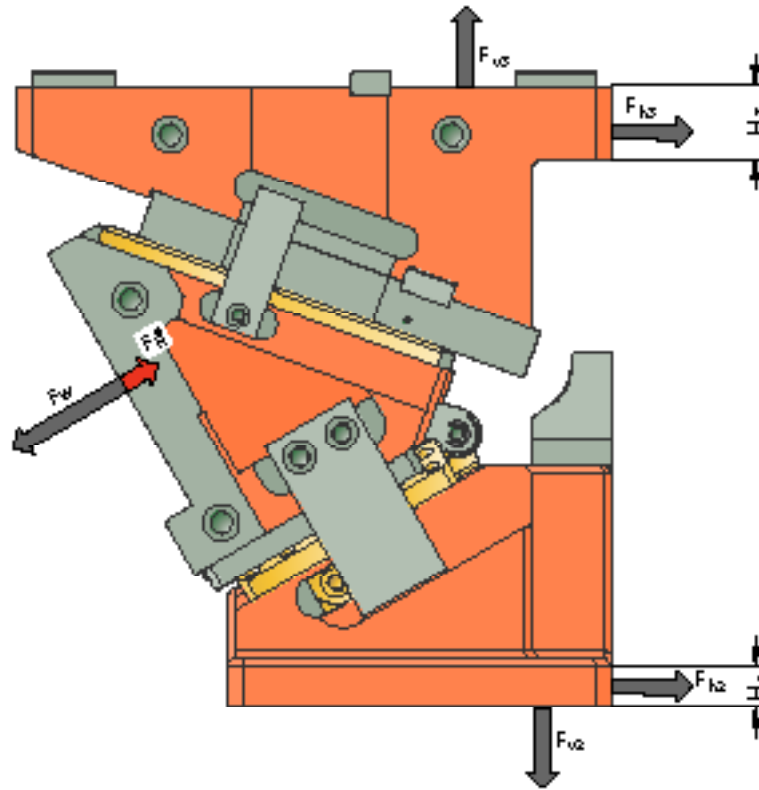

Order number	α [°]	F_W [kN]	F_R^* [kN]	F_{h2} [kN]	F_{v2} [kN]	F_{h3} [kN]	F_{v3} [kN]	H_2 [mm]	H_3 [mm]
2016.208.00.050.038.21	0	314	35.4	0	263	314	263	65	45
2016.208.05.050.042.21	5	314	35.5	23	262	290	290	75	45
2016.208.10.050.046.21	10	314	35.6	46	259	263	314	90	45
2016.208.15.050.050.21	15	314	35.7	68	254	235	336	110	45
2016.208.20.050.055.21	20	314	35.7	90	248	205	355	125	45
2016.208.25.050.060.21	25	314	35.7	111	239	173	371	140	45
2016.208.30.050.065.21	30	314	35.7	132	228	140	385	145	45
2016.208.35.050.070.21	35	314	35.7	151	216	106	396	150	45
2016.208.40.050.077.21	40	314	35.7	169	202	71	404	170	45
2016.208.45.050.084.21	45	314	35.7	186	186	36	408	175	45
2016.208.50.050.093.21	50	314	35.7	202	169	0	410	190	45
2016.208.55.050.104.21	55	314	39.3	180	126	0	383	205	45
2016.208.60.050.120.21	60	314	44.2	157	91	0	363	205	45

* Retraction force values correspond to the spring-generated retraction force at the working point

The forces F_{h2} , F_{v2} as well as F_{h3} , F_{v3} act on the tool environment at maximum working force F_W .



**AERIAL
ECO LINE
2016.208.□□.060.**

Working width: 600 mm
Performance class: 300 kN

AERIAL ECO LINE
2016.208.□□.060.
 SIZE TABLE

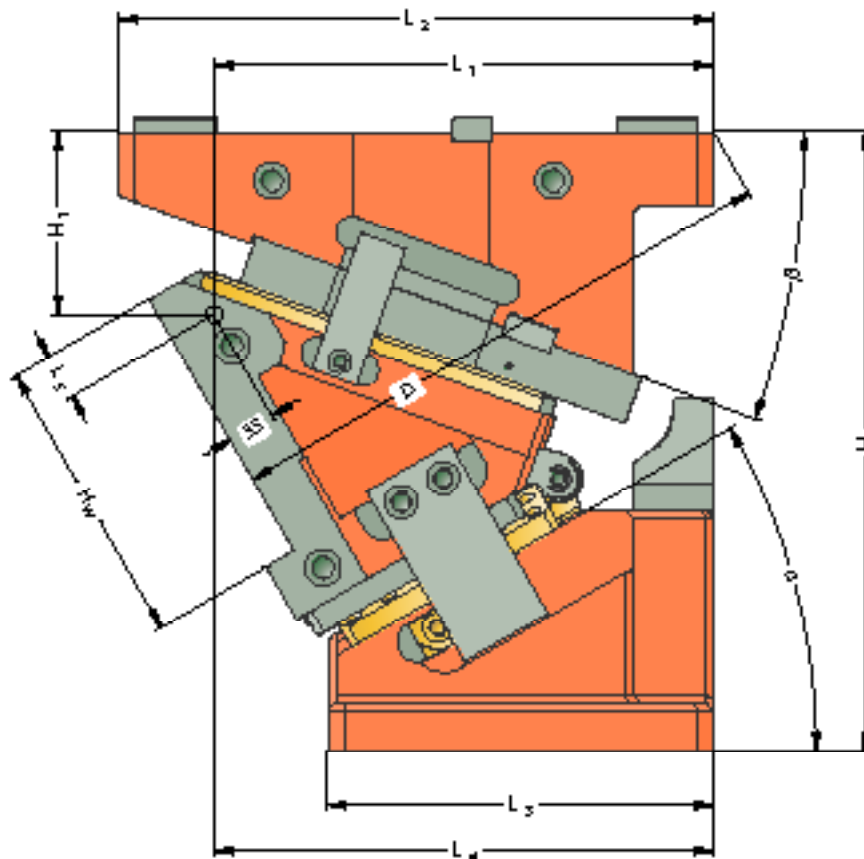
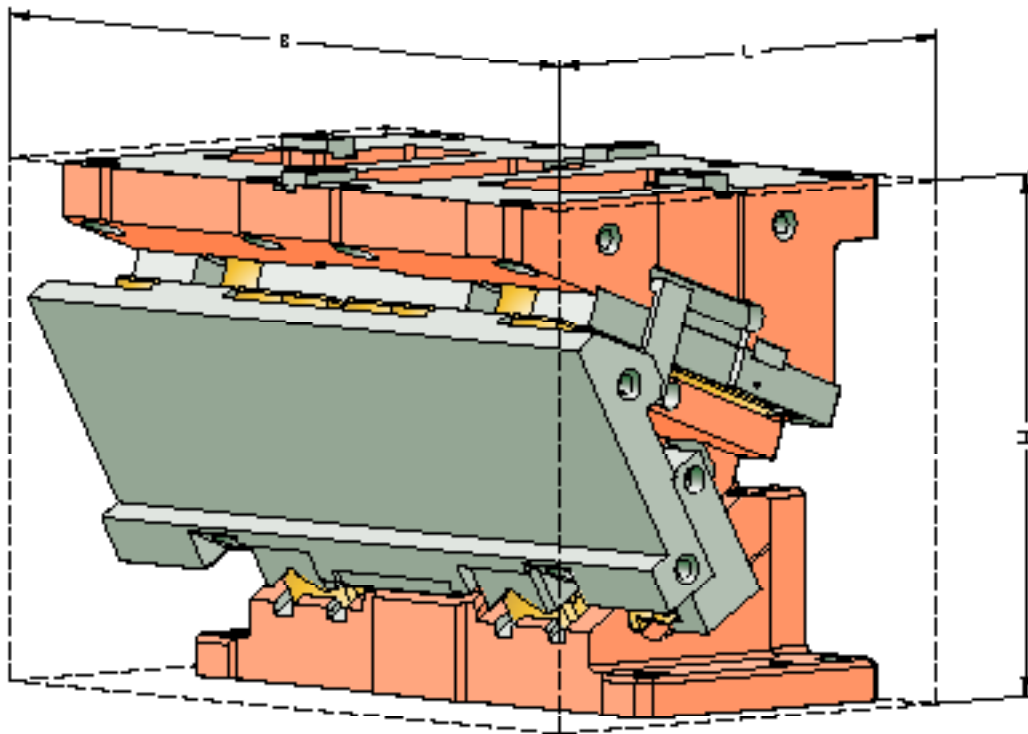

AERIAL ECO LINE

2016.208.□□.060.

SIZE TABLE

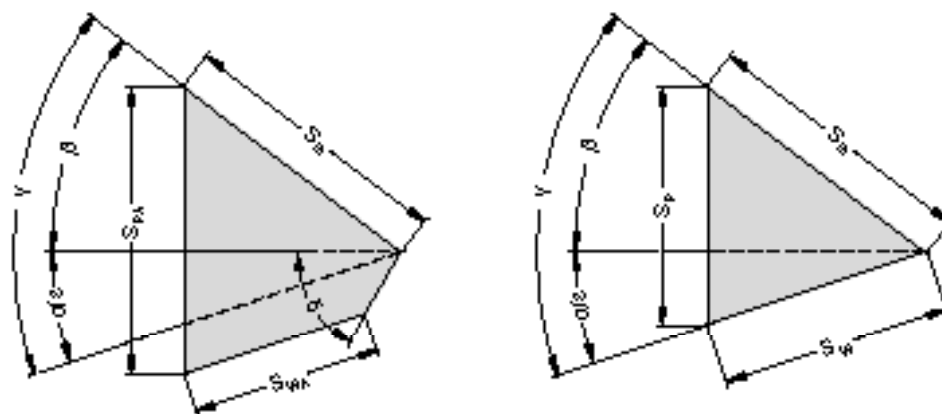

Order number	L	B	H	H ₁	H _W	L ₁	L ₂	L ₃	L ₄	L ₅	D	α	β	S _W *	S _{WA} *	S _S	S _P *	S _{PA} *
2016.208.	[mm]	[mm]	[mm]	[mm]	[mm]	[mm]	[mm]	[mm]	[mm]	[mm]	[mm]	[°]	[°]	[mm]	[mm]	[mm]	[mm]	[mm]
00.060.038.21	370	600	385	85	180	293	370	198	240	28	323	0	50	-	36.8	60	-	48.0
05.060.042.21	370	600	385	83.9	180	397.3	370	217.3	240	28	333.4	5	45	-	40.0	60	-	57.5
10.060.046.21	370	600	385	84.5	180	301.5	370	236.5	240	28	341.6	10	40	-	45.0	60	-	54.9
15.060.060.21	370	600	385	86.8	180	305.7	370	255.7	240	28	347.7	15	35	-	45.1	60	-	59.4
20.060.055.21	370	600	385	90.7	180	309.6	370	274.6	240	28	351.9	20	30	-	53.5	60	-	57.7
25.060.060.21	370	600	385	96.3	180	308	370	293	240	28	349.9	25	25	-	56.3	60	-	67.5
30.060.065.21	370	600	385	113.5	180	310.9	370	310.9	240	28	356	30	20	-	42.9	60	-	66.1
35.060.070.21	385	600	385	122.2	180	313.2	370	328.2	240	28	356.6	35	15	-	57.1	60	-	77.8
40.060.077.21	400	600	385	132.3	180	314.6	370	344.6	240	28	356	40	10	-	73.7	60	-	76.3
45.060.084.21	410	600	385	143.9	180	320	370	360	240	28	358	45	5	84.5	-	60	65.0	-
50.060.093.21	430	600	385	156.7	180	314.4	370	374.4	240	28	352.2	50	0	93.3	-	60	71.5	-
55.060.104.21	430	600	385	170.8	180	327.6	370	387.6	240	28	357.8	55	0	104.6	-	60	85.7	-
60.060.120.21	438.8	600	385	185.9	180	339.5	370	399.5	240	28	360.8	60	0	120.0	-	60	103.9	-

* Values rounded

Mounting cam base:

Hexagon socket head cap screws DIN EN ISO 4762
Dowel pins DIN EN ISO 8735

8x M20 / Strength class min. 8.8
2x ø16

Mounting cam driver:

Hexagon socket head cap screws DIN EN ISO 4762
Dowel pins DIN EN ISO 8735

4x M16 / Strength class min. 8.8
2x ø16

AERIAL ECO LINE
2016.208.□□.060.
 EXPLODED VIEW

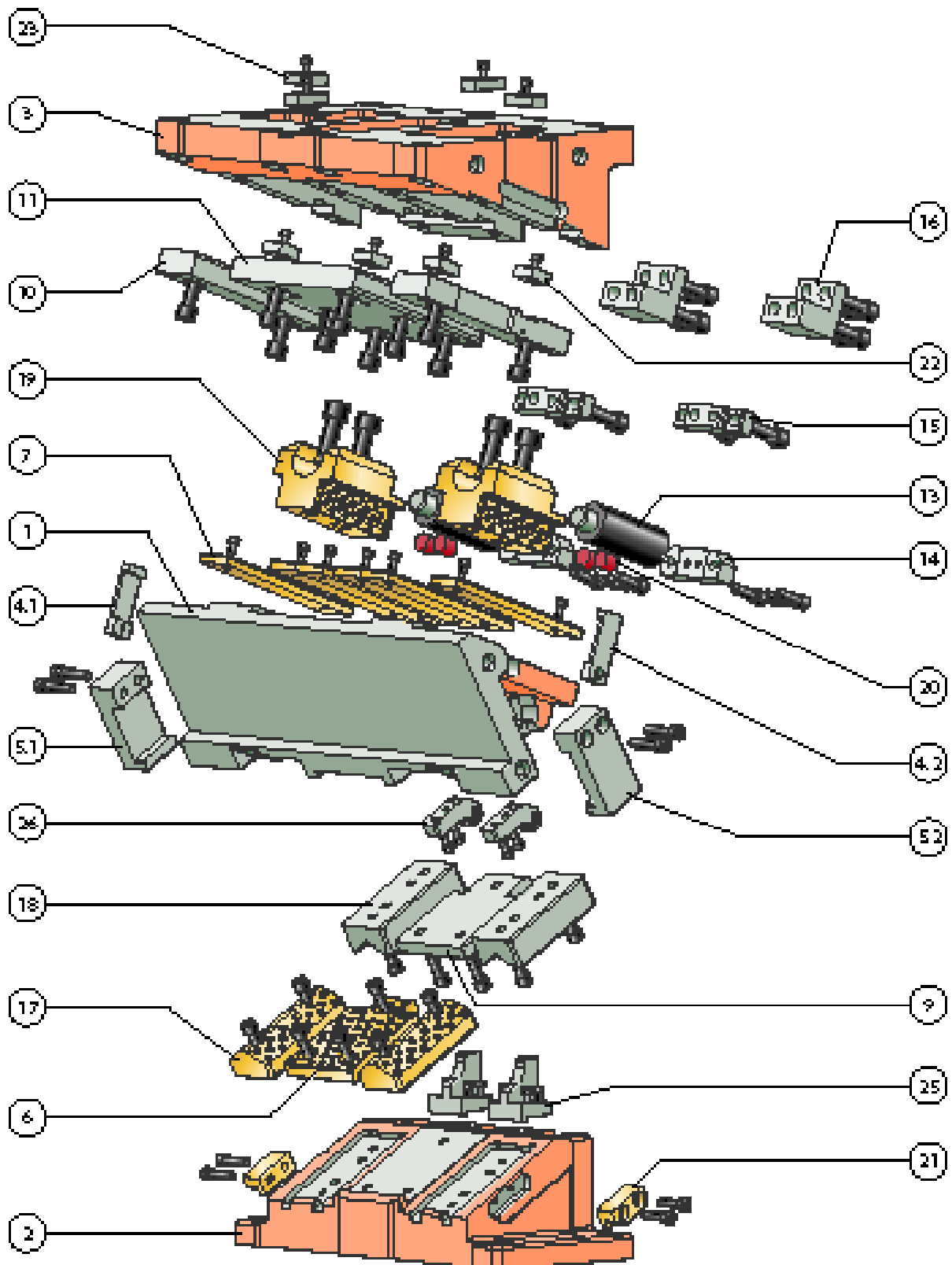

AERIAL ECO LINE

2016.208.□□.060.

PARTS LIST

Position	Piece	Designation	Material	spare part
1	1	Cam body		
2	1	Cam driver		
3	1	Cam base		
4.1	1	Clamp, left		x
4.2	1	Clamp, right		x
5.1	1	Positive return, left		x
5.2	1	Positive return, right		x
6	1	Sliding plate	Bronze with solid lubricant	x
7	6	Sliding plate	Bronze with solid lubricant	x
8				
9	1	Sliding plate	Steel	x
10	2	Sliding plate	Steel	x
11	1	Sliding plate	Steel	x
12				
13	2	Gas spring		x
14	2	Stop plate		x
15	2	Stop piece		x
16	2	Lockout system		x
17	2	Slide pad	Bronze with solid lubricant	x
18	2	Prismatic guide	Steel	x
19	2	Centre guide	Bronze with solid lubricant	x
20	4	Damper		x
21	2	Insert	Bronze with solid lubricant	x
22	4	Feather key		x
23	4	Feather key		x
24				
25*	2	Curve wedge		x
26*	2	Roller block		x
27				
28				

* up to and including 40° with pre-acceleration

For inquiries or when ordering spare parts (x), we require the following data:

- Cam unit order no.
- Cam unit serial number
- Item number / Designation / Spare part

AERIAL ECO LINE

2016.208.□□.060.

SYSTEM AND SURROUNDING FORCES

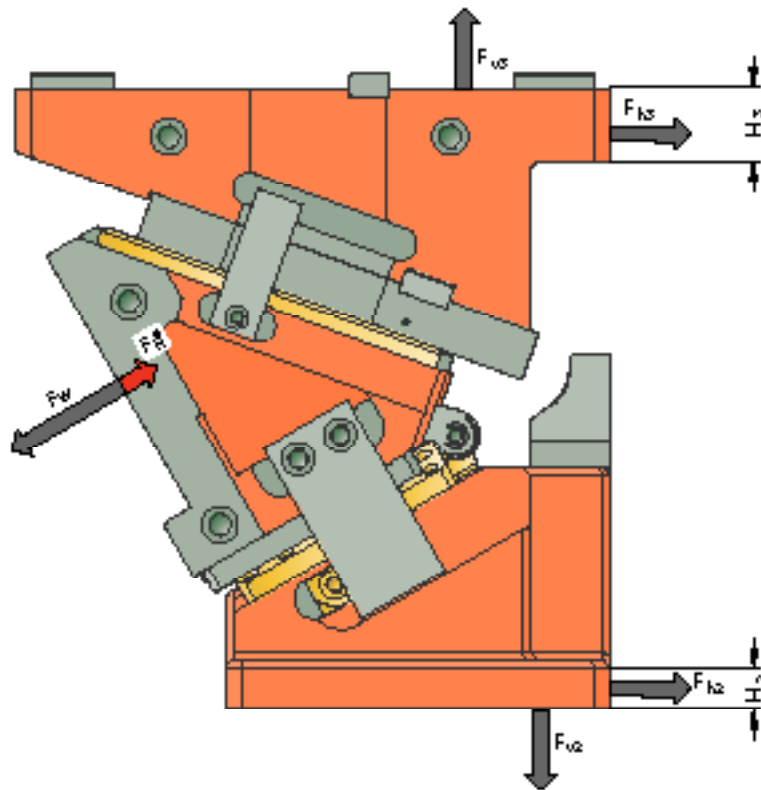

Order number	α [°]	F_W [kN]	F_R^* [kN]	F_{h2} [kN]	F_{v2} [kN]	F_{h3} [kN]	F_{v3} [kN]	H_2 [mm]	H_3 [mm]
2016.208.00.060.038.21	0	314	35.4	0	263	314	263	65	45
2016.208.05.060.042.21	5	314	35.5	23	262	290	290	75	45
2016.208.10.060.046.21	10	314	35.6	46	259	263	314	90	45
2016.208.15.060.060.21	15	314	35.7	68	254	235	336	110	45
2016.208.20.060.055.21	20	314	35.7	90	248	205	355	125	45
2016.208.25.060.060.21	25	314	35.7	111	239	173	371	140	45
2016.208.30.060.065.21	30	314	35.7	132	228	140	385	145	45
2016.208.35.060.070.21	35	314	35.7	151	216	106	396	150	45
2016.208.40.060.077.21	40	314	35.7	169	202	71	404	170	45
2016.208.45.060.084.21	45	314	35.7	186	186	36	408	175	45
2016.208.50.060.093.21	50	314	35.7	202	169	0	410	190	45
2016.208.55.060.104.21	55	314	39.3	180	126	0	383	205	45
2016.208.60.060.120.21	60	314	44.2	157	91	0	363	205	45

* Retraction force values correspond to the spring-generated retraction force at the working point

The forces F_{h2} , F_{v2} as well as F_{h3} , F_{v3} act on the tool environment at maximum working force F_W .



**AERIAL
ECO LINE
2016.208.□□.070.**

Working width: 700 mm
Performance class: 475 kN

AERIAL ECO LINE
2016.208.□□.070.
 SIZE TABLE

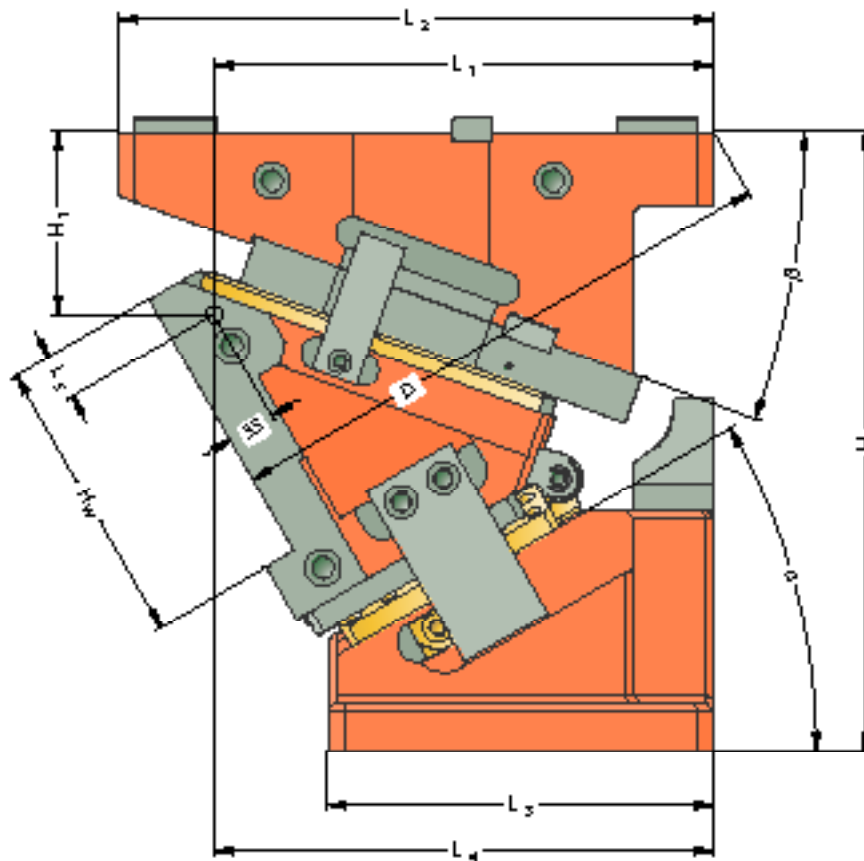
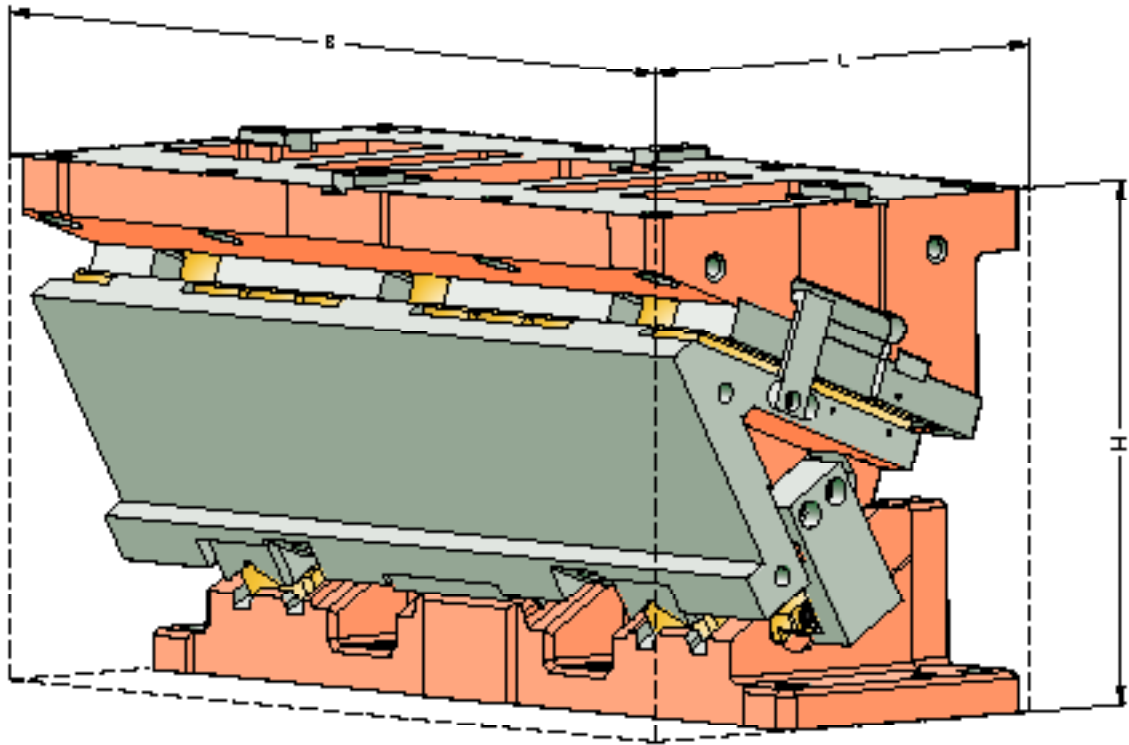

AERIAL ECO LINE

2016.208.□□.070.

SIZE TABLE

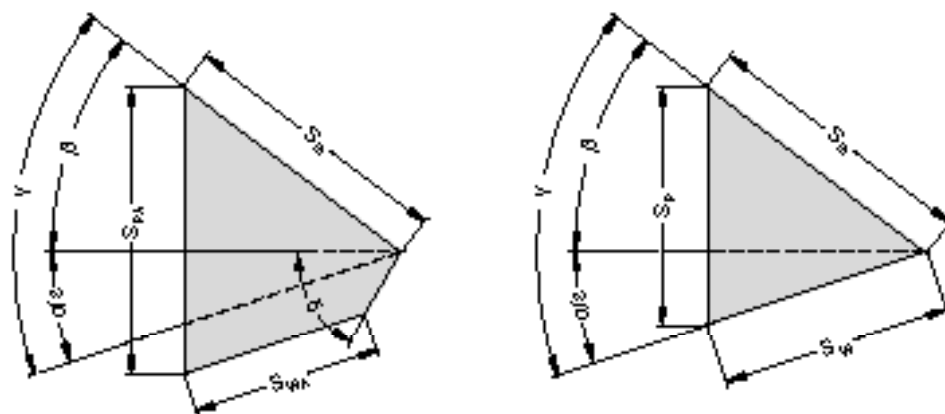

Order number	L	B	H	H ₁	H _w	L ₁	L ₂	L ₃	L ₄	L ₅	D	α	β	S _w *	S _{WA} *	S _s	S _p *	S _{PA} *
	[mm]	[mm]	[mm]	[mm]	[mm]	[mm]	[mm]	[mm]	[mm]	[mm]	[mm]	[°]	[°]	[mm]	[mm]	[mm]	[mm]	[mm]
2016.208.																		
00.070.038.21	370	700	385	85	180	293	370	198	240	28	323	0	50	-	36.8	60	-	48.0
05.070.042.21	370	700	385	83.9	180	397.3	370	217.3	240	28	333.4	5	45	-	40.0	60	-	57.5
10.070.046.21	370	700	385	84.5	180	301.5	370	236.5	240	28	341.6	10	40	-	45.0	60	-	54.9
15.070.070.21	370	700	385	86.8	180	305.7	370	255.7	240	28	347.7	15	35	-	45.1	60	-	59.4
20.070.055.21	370	700	385	90.7	180	309.6	370	274.6	240	28	351.9	20	30	-	53.5	60	-	57.7
25.070.060.21	370	700	385	96.3	180	308	370	293	240	28	349.9	25	25	-	56.3	60	-	67.5
30.070.065.21	370	700	385	113.5	180	310.9	370	310.9	240	28	356	30	20	-	42.9	60	-	66.1
35.070.070.21	385	700	385	122.2	180	313.2	370	328.2	240	28	356.6	35	15	-	57.1	60	-	77.8
40.070.077.21	400	700	385	132.3	180	314.6	370	344.6	240	28	356	40	10	-	73.7	60	-	76.3
45.070.084.21	410	700	385	143.9	180	320	370	360	240	28	358	45	5	84.5	-	60	65.0	-
50.070.093.21	430	700	385	156.7	180	314.4	370	374.4	240	28	352.2	50	0	93.3	-	60	71.5	-
55.070.104.21	430	700	385	170.8	180	327.6	370	387.6	240	28	357.8	55	0	104.6	-	60	85.7	-
60.070.120.21	438.8	700	385	185.9	180	339.5	370	399.5	240	28	360.8	60	0	120.0	-	60	103.9	-

* Values rounded

Mounting cam base:

Hexagon socket head cap screws DIN EN ISO 4762
Dowel pins DIN EN ISO 8735

8x M20 / Strength class min. 8.8
2x ø16

Mounting cam driver:

Hexagon socket head cap screws DIN EN ISO 4762
Dowel pins DIN EN ISO 8735

6x M16 / Strength class min. 8.8
2x ø16

AERIAL ECO LINE
2016.208.□□.070.
 EXPLODED VIEW

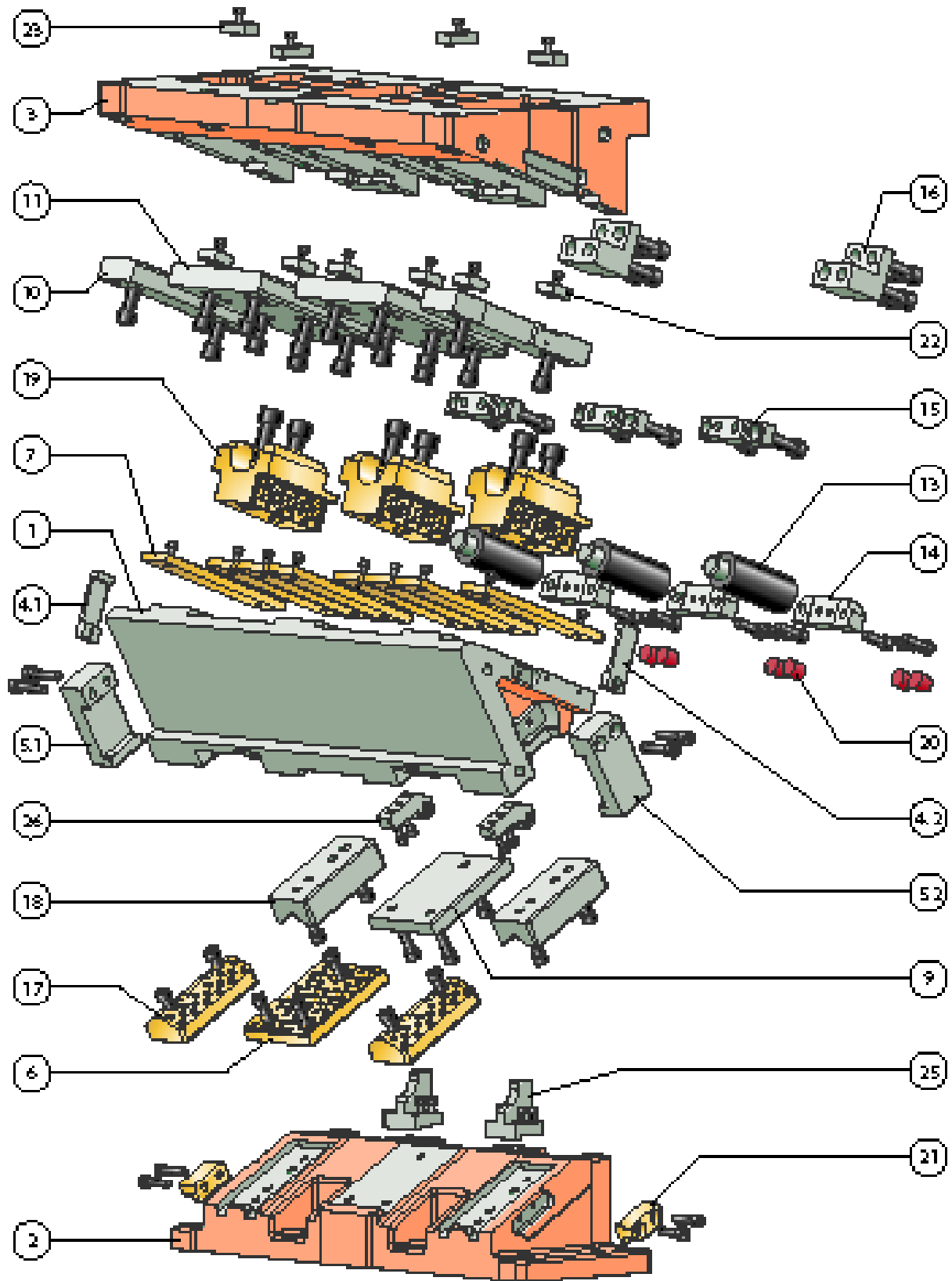

AERIAL ECO LINE

2016.208.□□.070.

PARTS LIST

Position	Piece	Designation	Material	spare part
1	1	Cam body		
2	1	Cam driver		
3	1	Cam base		
4.1	1	Clamp, left		x
4.2	1	Clamp, right		x
5.1	1	Positive return, left		x
5.2	1	Positive return, right		x
6	1	Sliding plate	Bronze with solid lubricant	x
7	8	Sliding plate	Bronze with solid lubricant	x
8				
9	1	Sliding plate	Steel	x
10	2	Sliding plate	Steel	x
11	2	Sliding plate	Steel	x
12				
13	3	Gas spring		x
14	3	Stop plate		x
15	3	Stop piece		x
16	2	Lockout system		x
17	2	Slide pad	Bronze with solid lubricant	x
18	2	Prismatic guide	Steel	x
19	3	Centre guide	Bronze with solid lubricant	x
20	6	Damper		x
21	2	Insert	Bronze with solid lubricant	x
22	6	Feather key		x
23	4	Feather key		x
24				
25*	2	Curve wedge		x
26*	2	Roller block		x
27				
28				

* up to and including 40° with pre-acceleration

For inquiries or when ordering spare parts (x), we require the following data:

- Cam unit order no.
- Cam unit serial number
- Item number / Designation / Spare part

AERIAL ECO LINE

2016.208.□□.070.

SYSTEM AND SURROUNDING FORCES

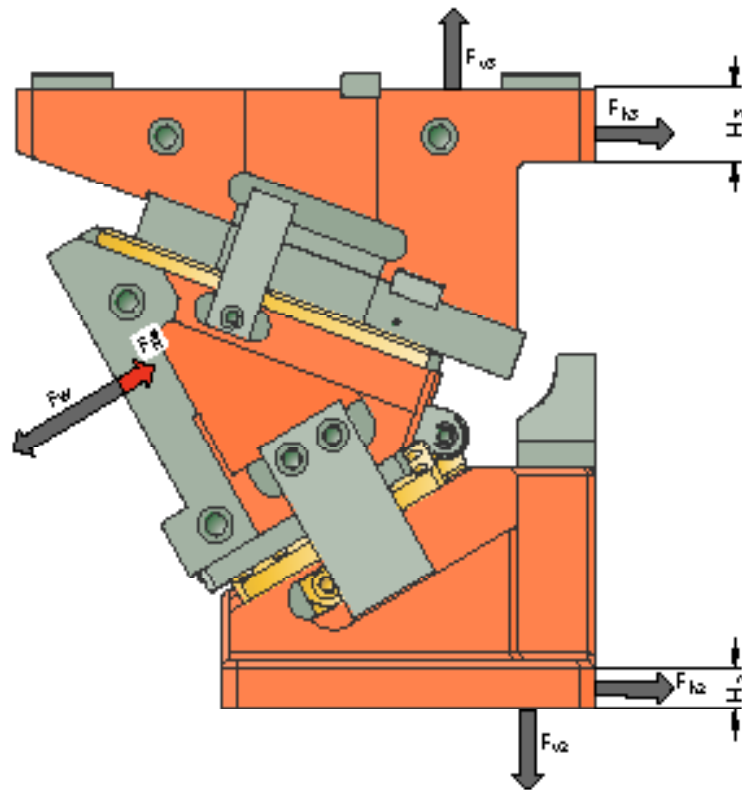

Order number	α [°]	F_W [kN]	F_R^* [kN]	F_{h2} [kN]	F_{v2} [kN]	F_{h3} [kN]	F_{v3} [kN]	H_2 [mm]	H_3 [mm]
2016.208.00.070.038.21	0	470	53.9	0	394	470	394	65	45
2016.208.05.070.042.21	5	470	54.2	34	393	434	434	75	45
2016.208.10.070.046.21	10	470	54.4	68	388	394	470	90	45
2016.208.15.070.070.21	15	470	54.5	102	381	352	503	110	45
2016.208.20.070.055.21	20	470	54.6	135	371	307	531	125	45
2016.208.25.070.060.21	25	470	54.6	167	357	259	556	140	45
2016.208.30.070.065.21	30	470	54.6	197	342	210	577	145	45
2016.208.35.070.070.21	35	470	54.6	226	323	159	593	150	45
2016.208.40.070.077.21	40	470	54.6	254	302	107	604	170	45
2016.208.45.070.084.21	45	470	54.6	279	279	53	611	175	45
2016.208.50.070.093.21	50	470	54.6	302	254	0	614	190	45
2016.208.55.070.104.21	55	470	60.3	270	189	0	574	205	45
2016.208.60.070.120.21	60	470	68.1	235	136	0	543	205	45

* Retraction force values correspond to the spring-generated retraction force at the working point

The forces F_{h2} , F_{v2} as well as F_{h3} , F_{v3} act on the tool environment at maximum working force F_W .



**AERIAL
ECO LINE
2016.208.□□.080.**

Working width: 800 mm
Performance class: 475 kN

AERIAL ECO LINE
2016.208.□□.080.
 SIZE TABLE

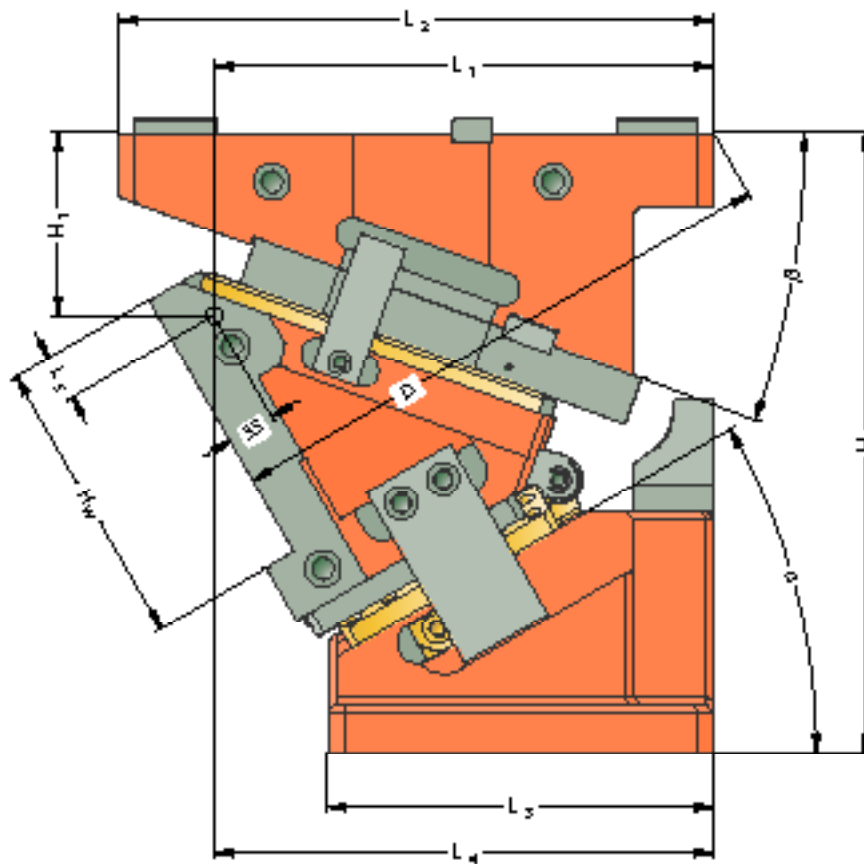
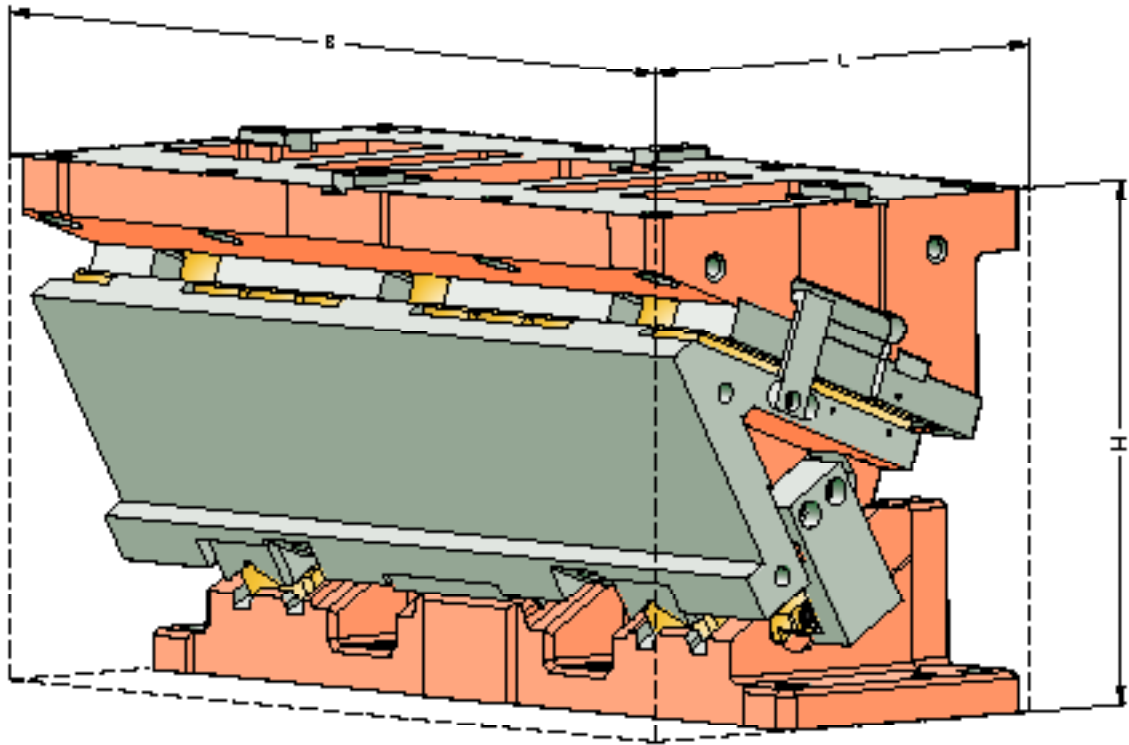

AERIAL ECO LINE

2016.208.□□.080.

SIZE TABLE

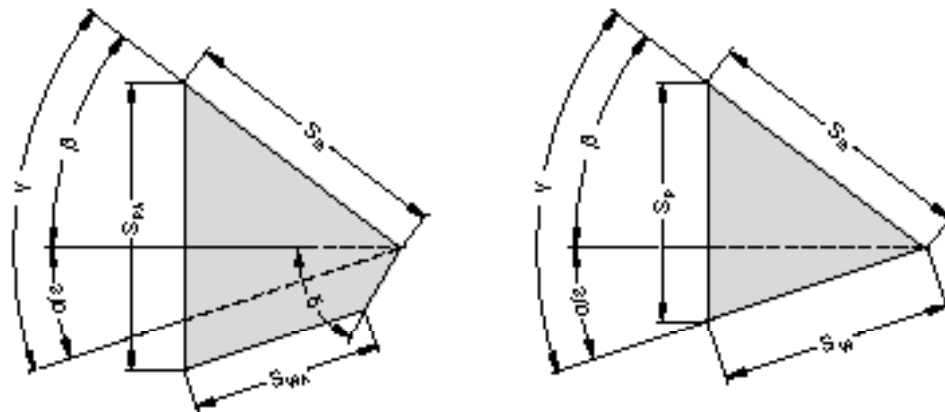

Order number	L	B	H	H ₁	H _W	L ₁	L ₂	L ₃	L ₄	L ₅	D	α	β	S _W *	S _{WA} *	S _S	S _P *	S _{PA} *
2016.208.	[mm]	[mm]	[mm]	[mm]	[mm]	[mm]	[mm]	[mm]	[mm]	[mm]	[mm]	[°]	[°]	[mm]	[mm]	[mm]	[mm]	[mm]
00.080.038.21	370	800	385	85	180	293	370	198	240	28	323	0	50	-	36.8	60	-	48.0
05.080.042.21	370	800	385	83.9	180	397.3	370	217.3	240	28	333.4	5	45	-	40.0	60	-	57.5
10.080.046.21	370	800	385	84.5	180	301.5	370	236.5	240	28	341.6	10	40	-	45.0	60	-	54.9
15.080.070.21	370	800	385	86.8	180	305.7	370	255.7	240	28	347.7	15	35	-	45.1	60	-	59.4
20.080.055.21	370	800	385	90.7	180	309.6	370	274.6	240	28	351.9	20	30	-	53.5	60	-	57.7
25.080.060.21	370	800	385	96.3	180	308	370	293	240	28	349.9	25	25	-	56.3	60	-	67.5
30.080.065.21	370	800	385	113.5	180	310.9	370	310.9	240	28	356	30	20	-	42.9	60	-	66.1
35.080.070.21	385	800	385	122.2	180	313.2	370	328.2	240	28	356.6	35	15	-	57.1	60	-	77.8
40.080.077.21	400	800	385	132.3	180	314.6	370	344.6	240	28	356	40	10	-	73.7	60	-	76.3
45.080.084.21	410	800	385	143.9	180	320	370	360	240	28	358	45	5	84.5	-	60	65.0	-
50.080.093.21	430	800	385	156.7	180	314.4	370	374.4	240	28	352.2	50	0	93.3	-	60	71.5	-
55.080.104.21	430	800	385	170.8	180	327.6	370	387.6	240	28	357.8	55	0	104.6	-	60	85.7	-
60.080.120.21	438.8	800	385	185.9	180	339.5	370	399.5	240	28	360.8	60	0	120.0	-	60	103.9	-

* Values rounded

Mounting cam base:

Hexagon socket head cap screws DIN EN ISO 4762
Dowel pins DIN EN ISO 8735

8x M20 / Strength class min. 8.8
2x ø16

Mounting cam driver:

Hexagon socket head cap screws DIN EN ISO 4762
Dowel pins DIN EN ISO 8735

6x M16 / Strength class min. 8.8
2x ø16

AERIAL ECO LINE
2016.208.□□.080.
 EXPLODED VIEW

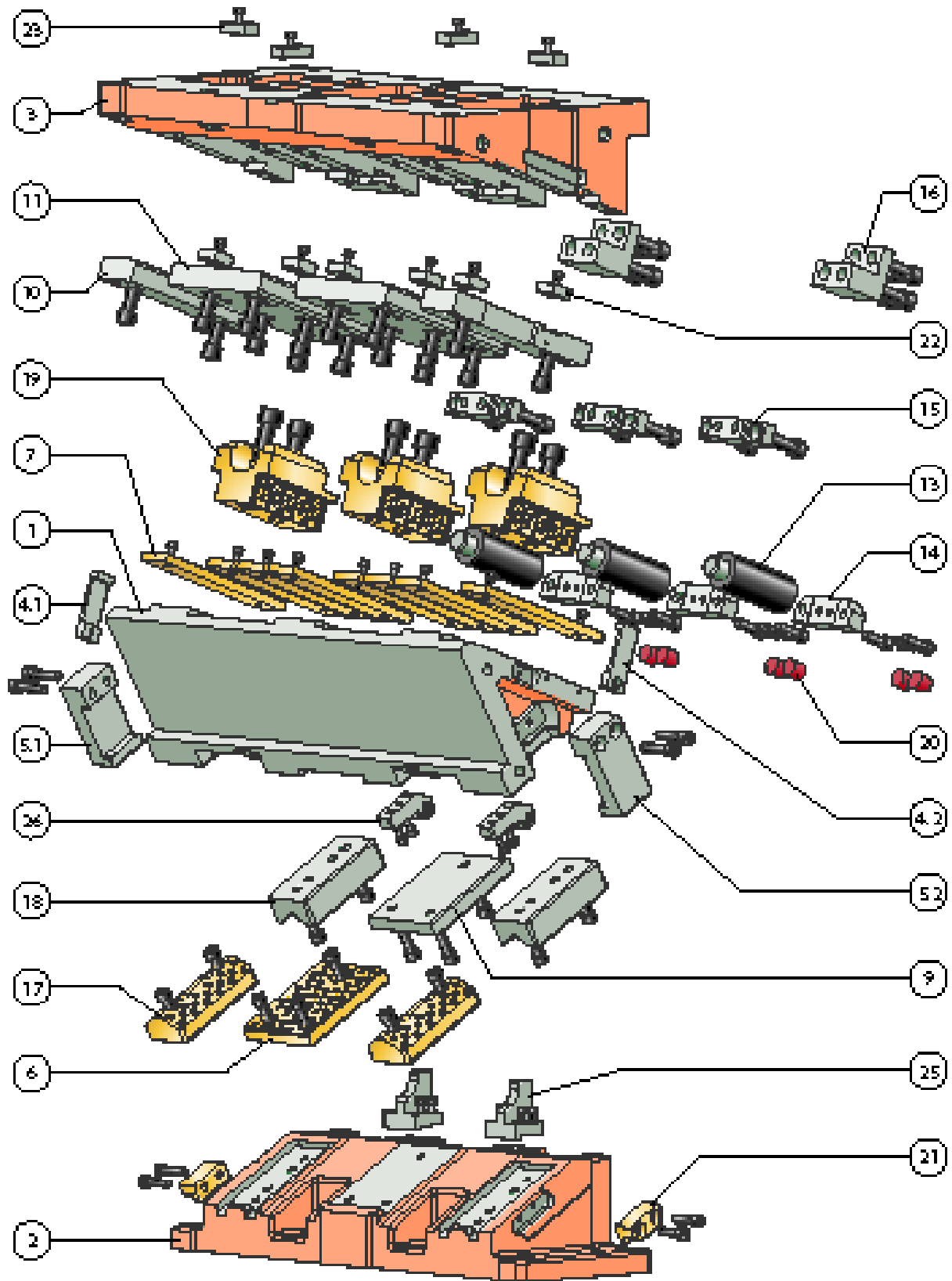

AERIAL ECO LINE

2016.208.□□.080.

PARTS LIST

Position	Piece	Designation	Material	spare part
1	1	Cam body		
2	1	Cam driver		
3	1	Cam base		
4.1	1	Clamp, left		x
4.2	1	Clamp, right		x
5.1	1	Positive return, left		x
5.2	1	Positive return, right		x
6	1	Sliding plate	Bronze with solid lubricant	x
7	8	Sliding plate	Bronze with solid lubricant	x
8				
9	1	Sliding plate	Steel	x
10	2	Sliding plate	Steel	x
11	2	Sliding plate	Steel	x
12				
13	3	Gas spring		x
14	3	Stop plate		x
15	3	Stop piece		x
16	2	Lockout system		x
17	2	Slide pad	Bronze with solid lubricant	x
18	2	Prismatic guide	Steel	x
19	3	Centre guide	Bronze with solid lubricant	x
20	6	Damper		x
21	2	Insert	Bronze with solid lubricant	x
22	6	Feather key		x
23	4	Feather key		x
24				
25*	2	Curve wedge		x
26*	2	Roller block		x
27				
28				

* up to and including 40° with pre-acceleration

For inquiries or when ordering spare parts (x), we require the following data:

- Cam unit order no.
- Cam unit serial number
- Item number / Designation / Spare part

AERIAL ECO LINE

2016.208.□□.080.

SYSTEM AND SURROUNDING FORCES

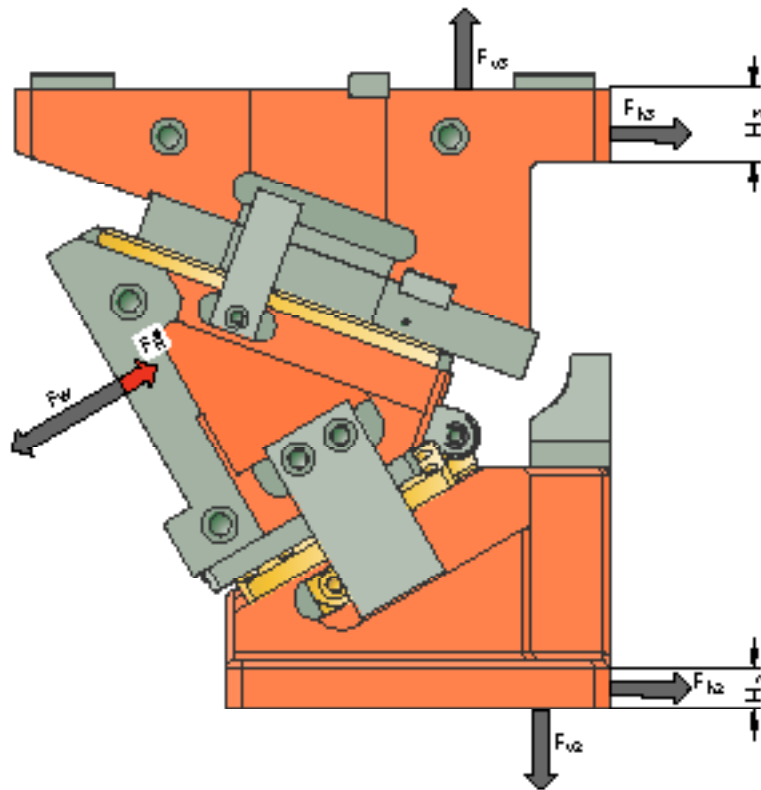

Order number	α [°]	F_W [kN]	F_R^* [kN]	F_{h2} [kN]	F_{v2} [kN]	F_{h3} [kN]	F_{v3} [kN]	H_2 [mm]	H_3 [mm]
2016.208.00.080.038.21	0	470	53.9	0	394	470	394	65	45
2016.208.05.080.042.21	5	470	54.2	34	393	434	434	75	45
2016.208.10.080.046.21	10	470	54.4	68	388	394	470	90	45
2016.208.15.080.080.21	15	470	54.5	102	381	352	503	110	45
2016.208.20.080.055.21	20	470	54.6	135	371	307	531	125	45
2016.208.25.080.060.21	25	470	54.6	167	357	259	556	140	45
2016.208.30.080.065.21	30	470	54.6	197	342	210	577	145	45
2016.208.35.080.070.21	35	470	54.6	226	323	159	593	150	45
2016.208.40.080.077.21	40	470	54.6	254	302	107	604	170	45
2016.208.45.080.084.21	45	470	54.6	279	279	53	611	175	45
2016.208.50.080.093.21	50	470	54.6	302	254	0	614	190	45
2016.208.55.080.104.21	55	470	60.3	270	189	0	574	205	45
2016.208.60.080.120.21	60	470	68.1	235	136	0	543	205	45

* Retraction force values correspond to the spring-generated retraction force at the working point

The forces F_{h2} , F_{v2} as well as F_{h3} , F_{v3} act on the tool environment at maximum working force F_W .



**AERIAL
ECO LINE
2016.208.□□.090.**

Working width: 900 mm
Performance class: 625 kN

AERIAL ECO LINE
2016.208.□□.090.
 SIZE TABLE

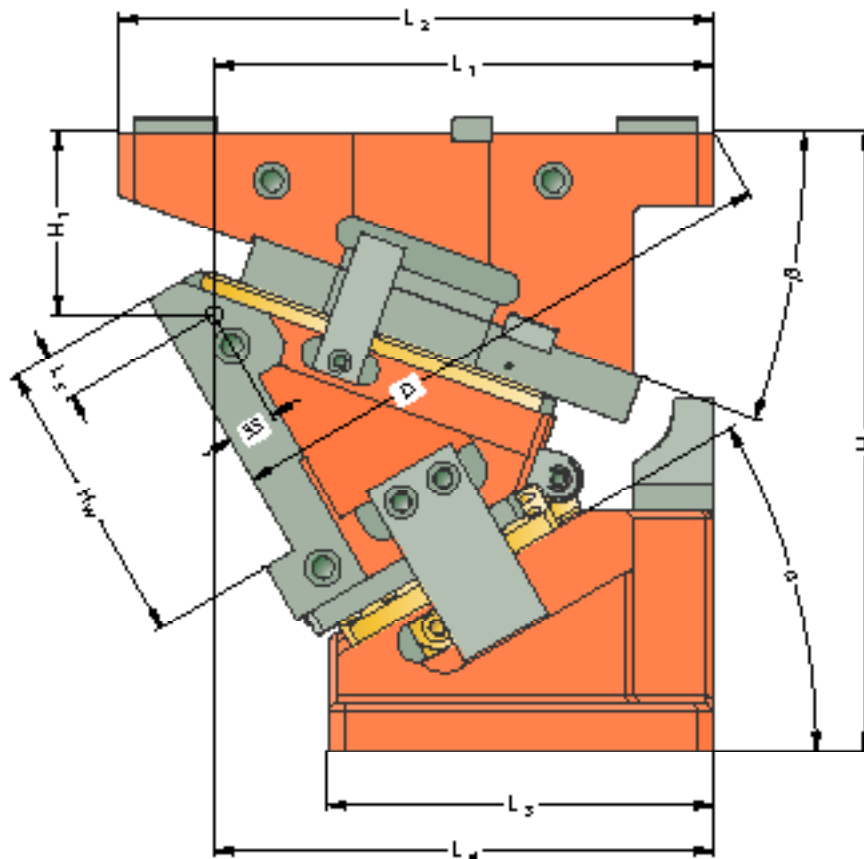
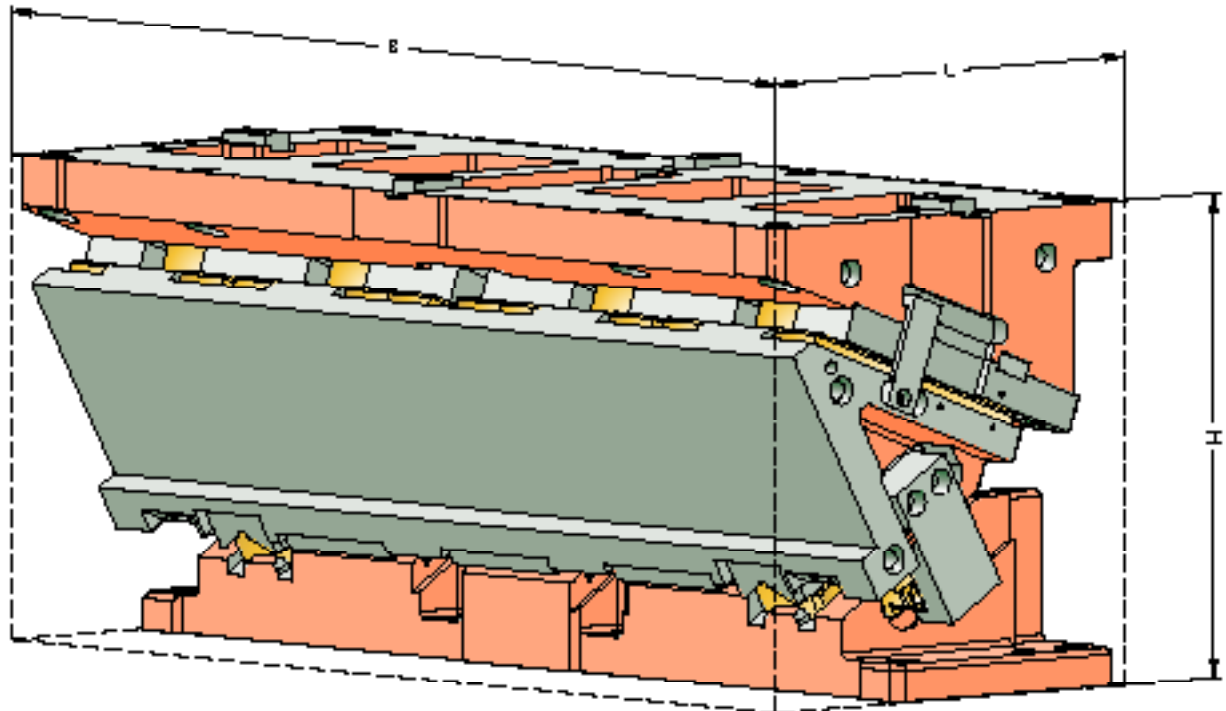

AERIAL ECO LINE

2016.208.□□.090.

SIZE TABLE

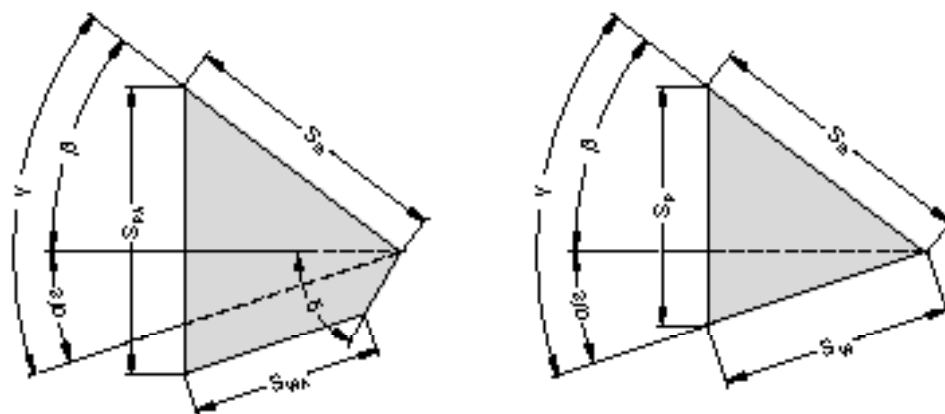

Order number	L	B	H	H ₁	H _W	L ₁	L ₂	L ₃	L ₄	L ₅	D	α	β	S _W *	S _{WA} *	S _S	S _P *	S _{PA} *
2016.208.	[mm]	[mm]	[mm]	[mm]	[mm]	[mm]	[mm]	[mm]	[mm]	[mm]	[mm]	[°]	[°]	[mm]	[mm]	[mm]	[mm]	[mm]
00.090.038.21	370	900	385	85	180	293	370	198	240	28	323	0	50	-	36.8	60	-	48.0
05.090.042.21	370	900	385	83.9	180	397.3	370	217.3	240	28	333.4	5	45	-	40.0	60	-	57.5
10.090.046.21	370	900	385	84.5	180	301.5	370	236.5	240	28	341.6	10	40	-	45.0	60	-	54.9
15.090.090.21	370	900	385	86.8	180	305.7	370	255.7	240	28	347.7	15	35	-	45.1	60	-	59.4
20.090.055.21	370	900	385	90.7	180	309.6	370	274.6	240	28	351.9	20	30	-	53.5	60	-	57.7
25.090.060.21	370	900	385	96.3	180	308	370	293	240	28	349.9	25	25	-	56.3	60	-	67.5
30.090.065.21	370	900	385	113.5	180	310.9	370	310.9	240	28	356	30	20	-	42.9	60	-	66.1
35.090.070.21	385	900	385	122.2	180	313.2	370	328.2	240	28	356.6	35	15	-	57.1	60	-	77.8
40.090.077.21	400	900	385	132.3	180	314.6	370	344.6	240	28	356	40	10	-	73.7	60	-	76.3
45.090.084.21	410	900	385	143.9	180	320	370	360	240	28	358	45	5	84.5	-	60	65.0	-
50.090.093.21	430	900	385	156.7	180	314.4	370	374.4	240	28	352.2	50	0	93.3	-	60	71.5	-
55.090.104.21	430	900	385	170.8	180	327.6	370	387.6	240	28	357.8	55	0	104.6	-	60	85.7	-
60.090.120.21	438.8	900	385	185.9	180	339.5	370	399.5	240	28	360.8	60	0	120.0	-	60	103.9	-

* Values rounded

Mounting cam base:

Hexagon socket head cap screws DIN EN ISO 4762
Dowel pins DIN EN ISO 8735

8x M20 / Strength class min. 8.8
2x ø16

Mounting cam driver:

Hexagon socket head cap screws DIN EN ISO 4762
Dowel pins DIN EN ISO 8735

7x M16 / Strength class min. 8.8
2x ø16

AERIAL ECO LINE
2016.208.□□.090.
 EXPLODED VIEW

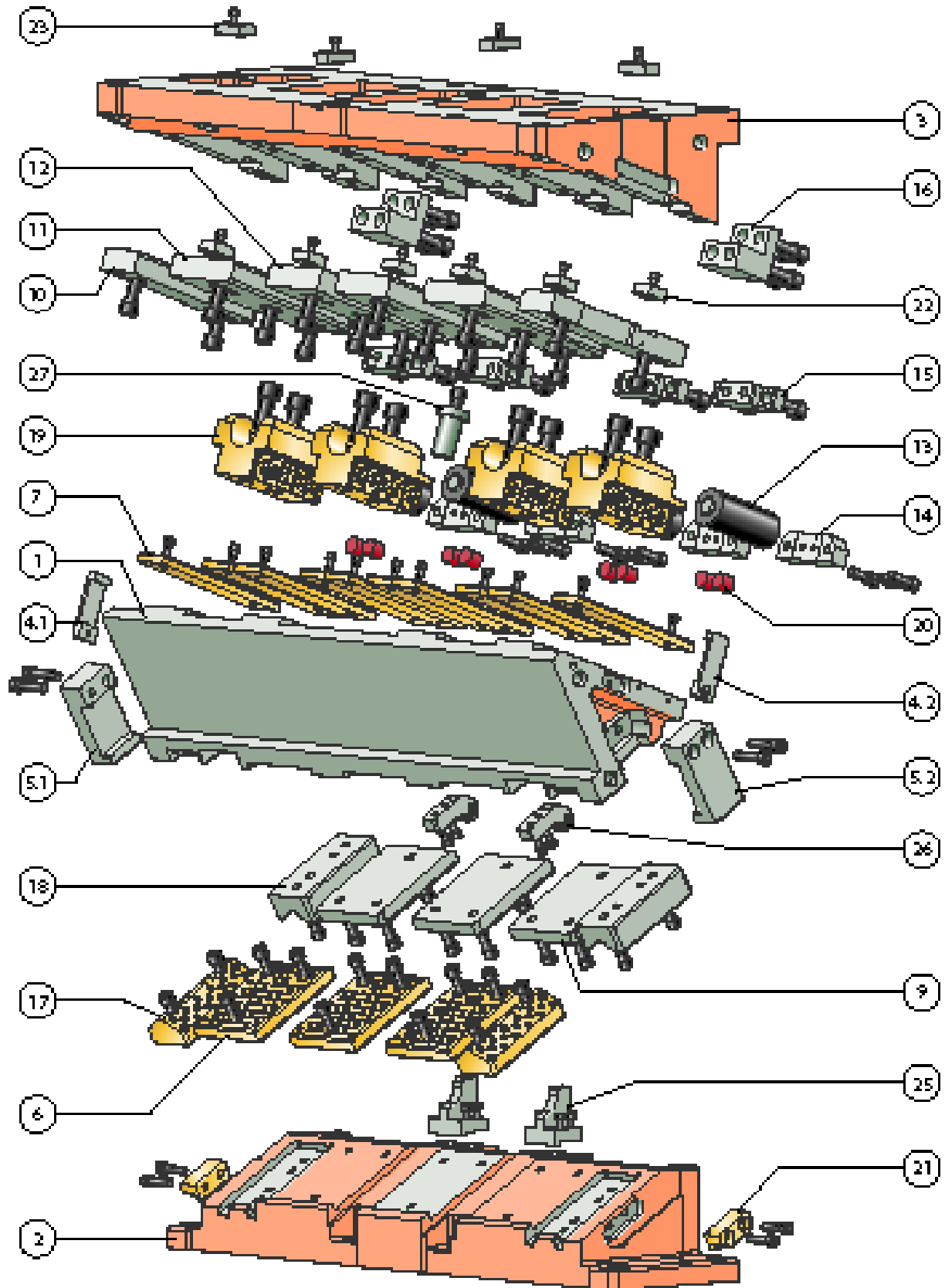

AERIAL ECO LINE

2016.208.□□.090.

PARTS LIST

Position	Piece	Designation	Material	spare part
1	1	Cam body		
2	1	Cam driver		
3	1	Cam base		
4.1	1	Clamp, left		x
4.2	1	Clamp, right		x
5.1	1	Positive return, left		x
5.2	1	Positive return, right		x
6	3	Sliding plate	Bronze with solid lubricant	x
7	10	Sliding plate	Bronze with solid lubricant	x
8				
9	3	Sliding plate	Steel	x
10	2	Sliding plate	Steel	x
11	2	Sliding plate	Steel	x
12	2	Sliding plate	Steel	x
13	4	Gas spring		x
14	4	Stop plate		x
15	4	Stop piece		x
16	2	Lockout system		x
17	2	Slide pad	Bronze with solid lubricant	x
18	2	Prismatic guide	Steel	x
19	4	Centre guide	Bronze with solid lubricant	x
20	8	Damper		x
21	2	Insert	Bronze with solid lubricant	x
22	6	Feather key		x
23	4	Feather key		x
24				
25*	2	Curve wedge		x
26*	2	Roller block		x
27	1	Safety bolt		x
28				

* up to and including 40° with pre-acceleration

For inquiries or when ordering spare parts (x), we require the following data:

- Cam unit order no.
- Cam unit serial number
- Item number / Designation / Spare part

AERIAL ECO LINE

2016.208.□□.090.

SYSTEM AND SURROUNDING FORCES

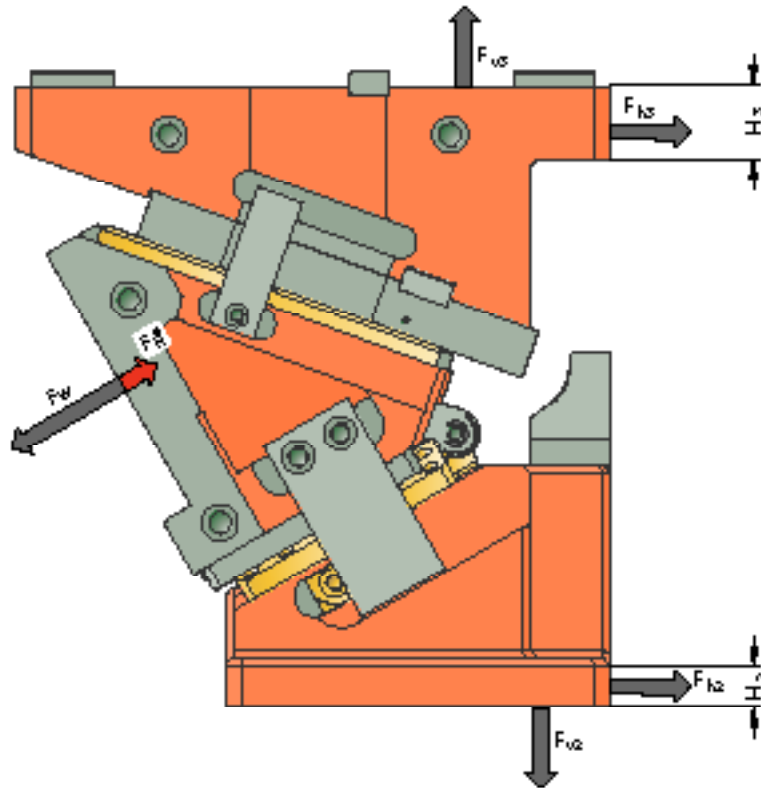

Order number	α [°]	F_W [kN]	F_R^* [kN]	F_{h2} [kN]	F_{v2} [kN]	F_{h3} [kN]	F_{v3} [kN]	H_2 [mm]	H_3 [mm]
2016.208.00.090.038.21	0	627	72.4	0	526	627	526	65	45
2016.208.05.090.042.21	5	627	72.8	46	524	579	579	75	45
2016.208.10.090.046.21	10	627	73.1	91	518	526	627	90	45
2016.208.15.090.090.21	15	627	73.2	136	508	469	670	110	45
2016.208.20.090.055.21	20	627	73.4	180	494	409	709	125	45
2016.208.25.090.060.21	25	627	73.4	222	477	346	742	140	45
2016.208.30.090.065.21	30	627	73.5	263	456	280	769	145	45
2016.208.35.090.070.21	35	627	73.5	302	431	212	791	150	45
2016.208.40.090.077.21	40	627	73.5	338	403	142	806	170	45
2016.208.45.090.084.21	45	627	73.6	372	372	71	815	175	45
2016.208.50.090.093.21	50	627	73.6	403	338	0	818	190	45
2016.208.55.090.104.21	55	627	81.3	360	252	0	765	205	45
2016.208.60.090.120.21	60	627	91.6	314	181	0	724	205	45

* Retraction force values correspond to the spring-generated retraction force at the working point

The forces F_{h2} , F_{v2} as well as F_{h3} , F_{v3} act on the tool environment at maximum working force F_W .



**AERIAL
ECO LINE
2016.208.□□.100.**

Working width: 1000 mm
Performance class: 625 kN

AERIAL ECO LINE
2016.208.□□.100.
 SIZE TABLE

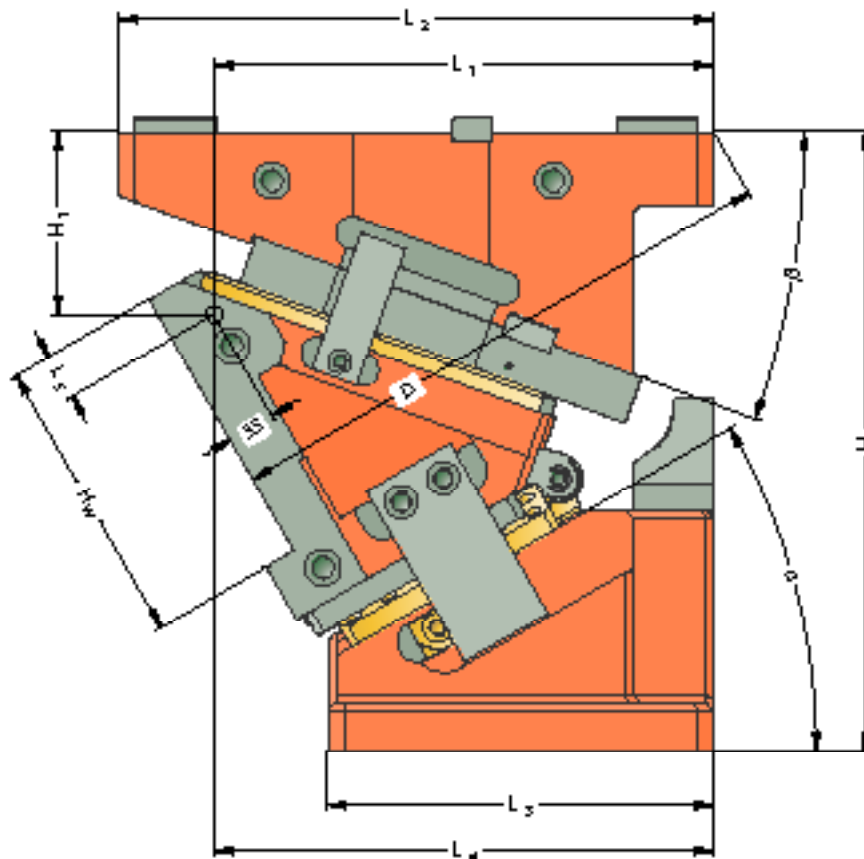
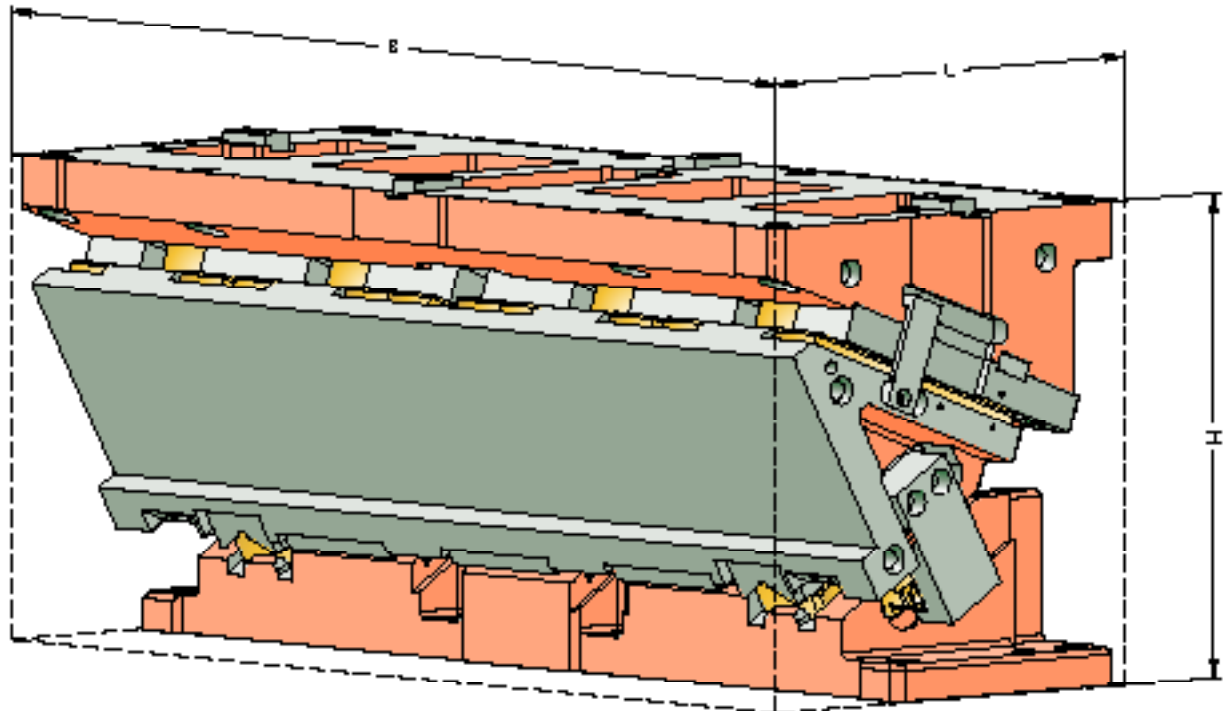

AERIAL ECO LINE

2016.208.□□.100.

SIZE TABLE

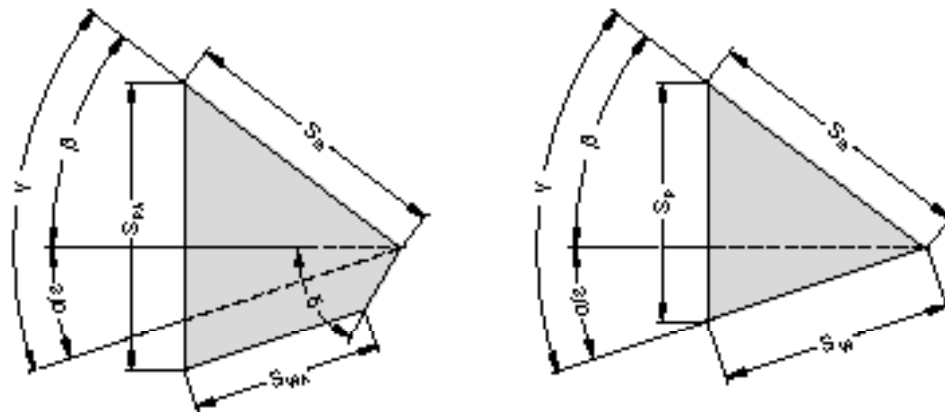

Order number	L	B	H	H ₁	H _W	L ₁	L ₂	L ₃	L ₄	L ₅	D	α	β	S _W *	S _{WA} *	S _S	S _P *	S _{PA} *
2016.208.	[mm]	[mm]	[mm]	[mm]	[mm]	[mm]	[mm]	[mm]	[mm]	[mm]	[mm]	[°]	[°]	[mm]	[mm]	[mm]	[mm]	[mm]
00.100.038.21	370	1000	385	85	180	293	370	198	240	28	323	0	50	-	36.8	60	-	48.0
05.100.042.21	370	1000	385	83.9	180	397.3	370	217.3	240	28	333.4	5	45	-	40.0	60	-	57.5
10.100.046.21	370	1000	385	84.5	180	301.5	370	236.5	240	28	341.6	10	40	-	45.0	60	-	54.9
15.100.100.21	370	1000	385	86.8	180	305.7	370	255.7	240	28	347.7	15	35	-	45.1	60	-	59.4
20.100.055.21	370	1000	385	90.7	180	309.6	370	274.6	240	28	351.9	20	30	-	53.5	60	-	57.7
25.100.060.21	370	1000	385	96.3	180	308	370	293	240	28	349.9	25	25	-	56.3	60	-	67.5
30.100.065.21	370	1000	385	113.5	180	310.9	370	310.9	240	28	356	30	20	-	42.9	60	-	66.1
35.100.070.21	385	1000	385	122.2	180	313.2	370	328.2	240	28	356.6	35	15	-	57.1	60	-	77.8
40.100.077.21	400	1000	385	132.3	180	314.6	370	344.6	240	28	356	40	10	-	73.7	60	-	76.3
45.100.084.21	410	1000	385	143.9	180	320	370	360	240	28	358	45	5	84.5	-	60	65.0	-
50.100.093.21	430	1000	385	156.7	180	314.4	370	374.4	240	28	352.2	50	0	93.3	-	60	71.5	-
55.100.104.21	430	1000	385	170.8	180	327.6	370	387.6	240	28	357.8	55	0	104.6	-	60	85.7	-
60.100.120.21	438.8	1000	385	185.9	180	339.5	370	399.5	240	28	360.8	60	0	120.0	-	60	103.9	-

* Values rounded

Mounting cam base:

Hexagon socket head cap screws DIN EN ISO 4762
Dowel pins DIN EN ISO 8735

8x M20 / Strength class min. 8.8
2x ø16

Mounting cam driver:

Hexagon socket head cap screws DIN EN ISO 4762
Dowel pins DIN EN ISO 8735

7x M16 / Strength class min. 8.8
2x ø16

AERIAL ECO LINE
2016.208.□□.100.
 EXPLODED VIEW

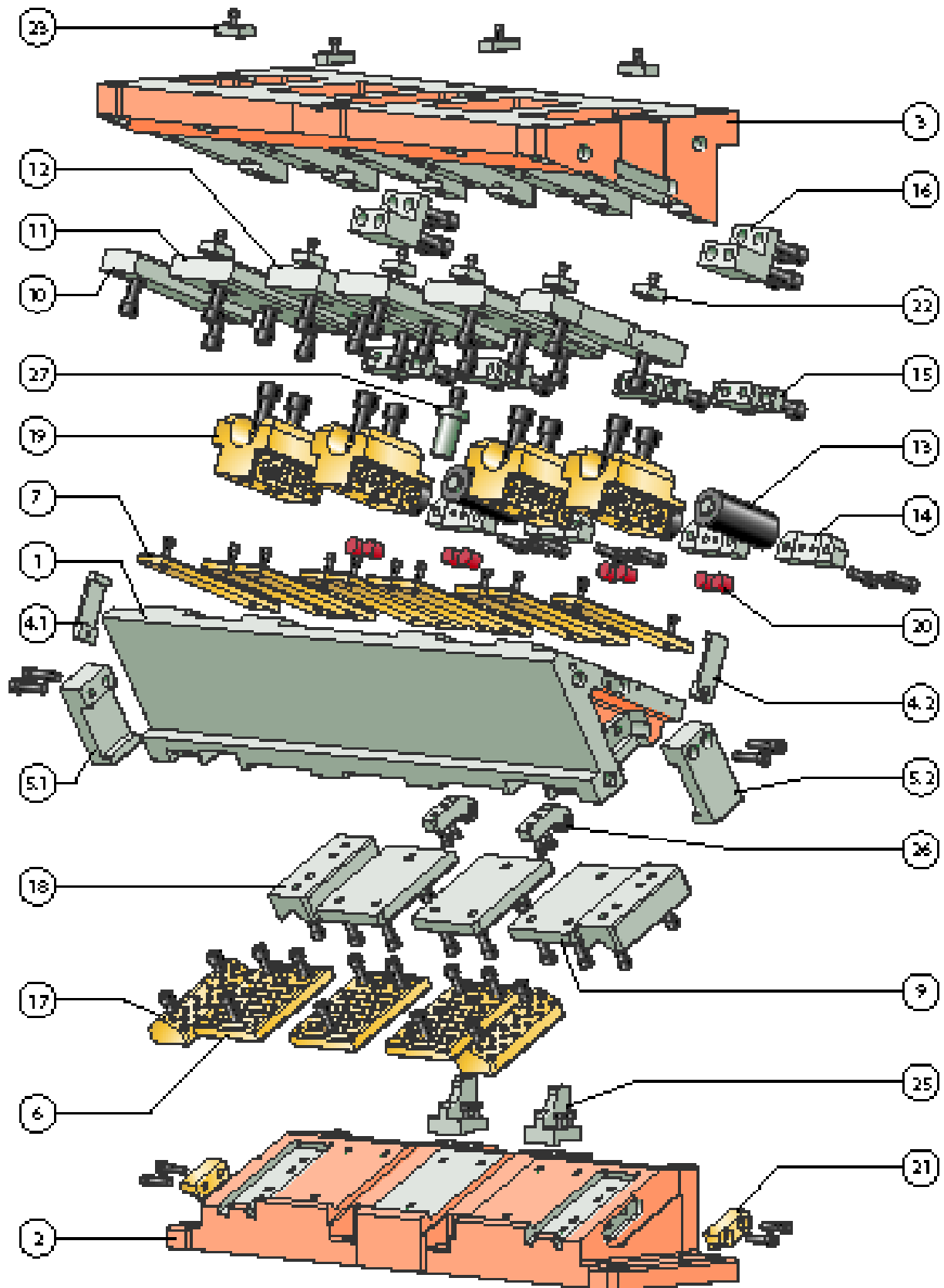

AERIAL ECO LINE

2016.208.□□.100.

PARTS LIST

Position	Piece	Designation	Material	spare part
1	1	Cam body		
2	1	Cam driver		
3	1	Cam base		
4.1	1	Clamp, left		x
4.2	1	Clamp, right		x
5.1	1	Positive return, left		x
5.2	1	Positive return, right		x
6	3	Sliding plate	Bronze with solid lubricant	x
7	10	Sliding plate	Bronze with solid lubricant	x
8				
9	3	Sliding plate	Steel	x
10	2	Sliding plate	Steel	x
11	2	Sliding plate	Steel	x
12	2	Sliding plate	Steel	x
13	4	Gas spring		x
14	4	Stop plate		x
15	4	Stop piece		x
16	2	Lockout system		x
17	2	Slide pad	Bronze with solid lubricant	x
18	2	Prismatic guide	Steel	x
19	4	Centre guide	Bronze with solid lubricant	x
20	8	Damper		x
21	2	Insert	Bronze with solid lubricant	x
22	6	Feather key		x
23	4	Feather key		x
24				
25*	2	Curve wedge		x
26*	2	Roller block		x
27	1	Safety bolt		x
28				

* up to and including 40° with pre-acceleration

For inquiries or when ordering spare parts (x), we require the following data:

- Cam unit order no.
- Cam unit serial number
- Item number / Designation / Spare part

AERIAL ECO LINE

2016.208.□□.100.

SYSTEM AND SURROUNDING FORCES

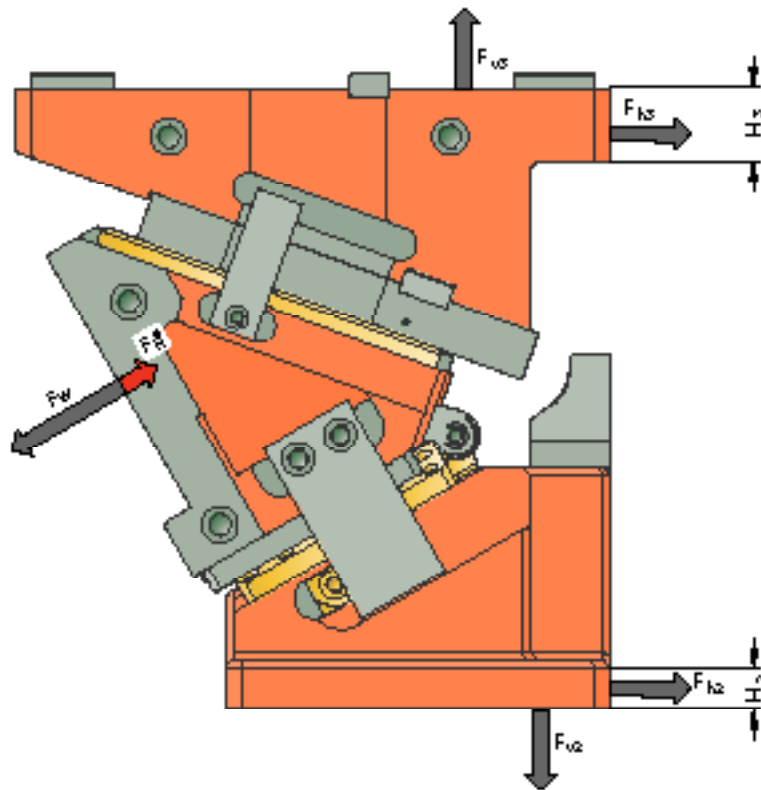

Order number	α [°]	F_W [kN]	F_R^* [kN]	F_{h2} [kN]	F_{v2} [kN]	F_{h3} [kN]	F_{v3} [kN]	H_2 [mm]	H_3 [mm]
2016.208.00.100.038.21	0	627	72.4	0	526	627	526	65	45
2016.208.05.100.042.21	5	627	72.8	46	524	579	579	75	45
2016.208.10.100.046.21	10	627	73.1	91	518	526	627	90	45
2016.208.15.100.100.21	15	627	73.2	136	508	469	670	110	45
2016.208.20.100.055.21	20	627	73.4	180	494	409	709	125	45
2016.208.25.100.060.21	25	627	73.4	222	477	346	742	140	45
2016.208.30.100.065.21	30	627	73.5	263	456	280	769	145	45
2016.208.35.100.070.21	35	627	73.5	302	431	212	791	150	45
2016.208.40.100.077.21	40	627	73.5	338	403	142	806	170	45
2016.208.45.100.084.21	45	627	73.6	372	372	71	815	175	45
2016.208.50.100.093.21	50	627	73.6	403	338	0	818	190	45
2016.208.55.100.104.21	55	627	81.3	360	252	0	765	205	45
2016.208.60.100.120.21	60	627	91.6	314	181	0	724	205	45

* Retraction force values correspond to the spring-generated retraction force at the working point

The forces F_{h2} , F_{v2} as well as F_{h3} , F_{v3} act on the tool environment at maximum working force F_W .

INTRODUCTION AND TABLE OF CONTENTS

ENGINEERING

2016.24. AERIAL FCC BAK

DAIMLER, VOLVO,
VOLKSWAGEN GROUP

2016.25. AERIAL FCC BAK

DAIMLER, VOLVO,
VOLKSWAGEN GROUP

2016.207. AERIAL ECO LINE

2016.208. AERIAL ECO LINE

**CUSTOMER-SPECIFIC
SERVICES**

APPENDIX

**EMERGENCY SITUATION /
CONTACTS**

CUSTOMER-SPECIFIC SERVICES

SPECIAL MACHINING

Catalogue cam units are equipped with a tool-specific machining for the tool in the mounting surface so that the required components can be fixed on the mounting surface. This machining is performed in the classical process of the toolmaking, often in a certain maturity of the tool itself as well. Process responsibility and risk lie with the executing tool shop.

As a service, FIBRO offers the complete machining of catalogue cam units according to customer specifications. The machining is closely matched to the customer requirements of their tooling process. In addition to conventional qualities, which serve the requirements of classical tooling processes, FIBRO also offers a high-precision finishing of cam units, which are equipped on cam units to be ready for operation (efp*). efp* equipped cam units allow the cam unit to be mounted in the tool with a subsequent initial test press stroke in the tool without further adjustment measures of the cam unit. As a result of processing at FIBRO as extended workbench, we assume the responsibility for the entire cam unit manufacturing process.

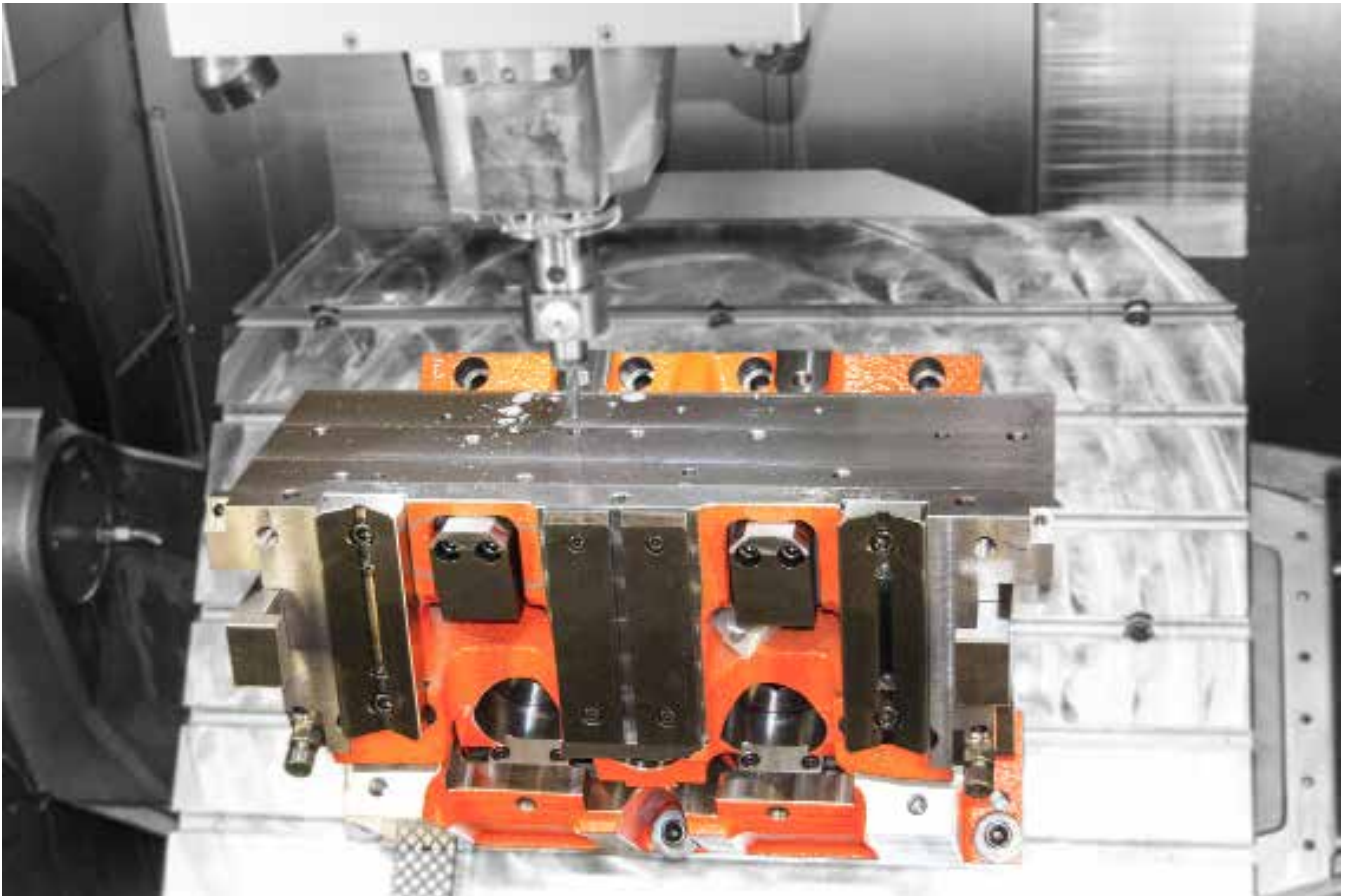

Figure 31: Special machining of cam units according to customer data

The tool-specific machining of cam units by FIBRO allows you to further rectify your processes in toolmaking. In addition to relieving logistical capacities, the machining, testing and cleaning of the cam units in your facility is also dispensed with. You keep limited capacities in your mechanical manufacturing and assembly free for other tasks, thus reducing the processing time of the tools and ultimately saving costs.

CUSTOMER-SPECIFIC SERVICES

SPECIAL MACHINING

If you want a tool-specific machining of the cam unit working surface, you can clarify your process-specific requirements, ideally at an early stage before the first order. The cam unit working surface is machined according to the data you provide. Our process is set up for the processing of 3D data in a variety of formats. We prefer to accept data in the format CATIA V5, but we can also process other native and data exchange formats such as step. In order to transfer important information for production, the data must be processed according to a clearly agreed methodology. As a well-established standard, the colour coding of the machined objects has been established according to the colour coding in accordance with the basic guideline for equipment constructions of the German automotive industry (see register APPENDIX "CAD colour coding ..."). Naturally, you can also take your own factory standards into account. The selected standard will be clearly agreed upon with us and clarified in advance.

In the course of an order, we will require the working stock number (tool number) as well as the item numbers of the cam units with special machining. For the respective cam units, the tool-specific machining of the working surface must be noted on the order as an additional text in the order (e.g. "Machining according to CAD data"). The order must be received in time so that the desired delivery date can be met. The regular delivery time for cam units with a specific machining of the mounting surface is 5 to 8 weeks. The actual delivery date depends on the availability of the approved production data. These should be received by us 15 working days before the desired delivery date in the agreed quality. A delayed receipt of the data may lead to a delay in delivery.

Please note that modified requirements to the machining can no longer be ensured after approved production data has already been provided, and this can result in the accepted delivery dates being postponed.

We will be glad to advise you on further questions and we will send you an appropriate offer if you wish.

*efp = equipped for press

CUSTOMER-SPECIFIC SERVICES

CUSTOMER-SPECIFIC CAM UNITS

In many toolmaking areas, purchased cam units are established as a cost-efficient option. Standard solutions can be used for a wide range of applications thanks to a diversified range of cam unit series.

Complex component geometries, overlaps with mechanisation devices or modified geometrical requirements on cam units do not permit the use of standard cam units in various cases. Tool-specifically configured cam units from FIBRO represent an alternative to the self-constructed and self-made cam units used here. This allows application-specific requirements to be combined with the advantages of standard purchase cam units.

Take advantage of our expertise

FIBRO develops tool-specific cam units according to the same technical standards as catalogue cam units. By inquiring at an early stage, we can closely accompany you in the development of dies, and you also have the possibility to design an optimal solution for your application. Our tool-specific cam units means there is no longer any additional logistical effort required in your procurement processes as well as in the parts supply in the workshop. The installation of the tool-specific configured cam unit corresponds to the process sequences of catalogue cam units, assembly and tuning measures within a self-made cam unit are no longer required. The analytical design of these cam units is the basic requirement for a smooth application over the intended life cycle of the cam unit. However, should undesirable wear occur during the tool lifetime, a rapid spare part supply is ensured by the use of a maximum number of standard parts in the cam unit. Through the entire tool development and assembly process, as well as the entire lifetime of the cam unit, FIBRO is thus your competent contact person for all your cam unit questions.

Features customised cam units

Tool-specific configured cam units from FIBRO generally have the same properties and qualities as our catalogue cam units. In general, we can realize working widths up to 1100 mm for you. The conversion possibilities of working widths greater than 1100 mm must be clarified in advance.

What is the process?

Tool-specific cam units are always used when a standard cam unit cannot meet the requirements of the tool. These can be very simple changes, such as a widened working surface, but also very complex scope of changes, such as complete offset cam unit components, multiple working surfaces, modified stiffnesses, etc.

The descriptions as exact as possible of your requirements for the cam unit are the basis for an target-oriented engineering of your tool-specific cam unit. In addition to the desired design principle (on which series your customer-specific cam unit will be based), we will also require a detailed description of the extent of change. Alternatively, you have the possibility to describe your problem to us in the tool and to provide us with design data from your tool (for example, part position, method plan, maximum possible space for the cam unit) as well as the tool environment (e.g. restrictions on mechanisation devices). In this case, FIBRO can handle the entire engineering of the customer-specific cam unit for you.

Of course, you also have the possibility to send us modified CAD data from our catalogue cam units, from which we can then extract the properties of your tool-specific cam unit. The plausibility and feasibility test as well as the manufacturing technology preparation with resultant possible technical modifications are made in our facility due to reasons of the warranty.

CUSTOMER-SPECIFIC SERVICES

CUSTOMER-SPECIFIC CAM UNITS

Normally, you will receive a CAD design draft of the tool-specific cam unit within 3 working days of your request. In the data format CATIA V5, or alternatively in the neutral exchange format STEP, as well as the article number associated with the cam unit. Via these, it is possible for us to clearly assign further arrangements during course of the project, and the cam unit can be procured from us in this way. In parallel to the design, our sales department will work out an offer for you for the tool-specific cam unit.

The manufacturing-technical detailing as well as the production of the tool-specific cam unit only occurs after you give a production go-ahead. After this production go-ahead, bigger changes, for example a change in the cam unit angle are still only conditionally possible according to the progress of the production, and at this point absolutely require an agreement with us. Changes after the production go-ahead may result in additional costs and delays in delivery.

Due to manufacturing reasons, you should give the production go-ahead of the tool-specific cam unit 8 weeks before your desired delivery time. A delayed production go-ahead can lead to a delay in delivery; shorter delivery periods must be agreed with us at an early stage.

If you have any additional questions, our technology and sales departments will be happy to assist you. Contact persons, see the “EMERGENCY SITUATION / CONTACTS” tab.

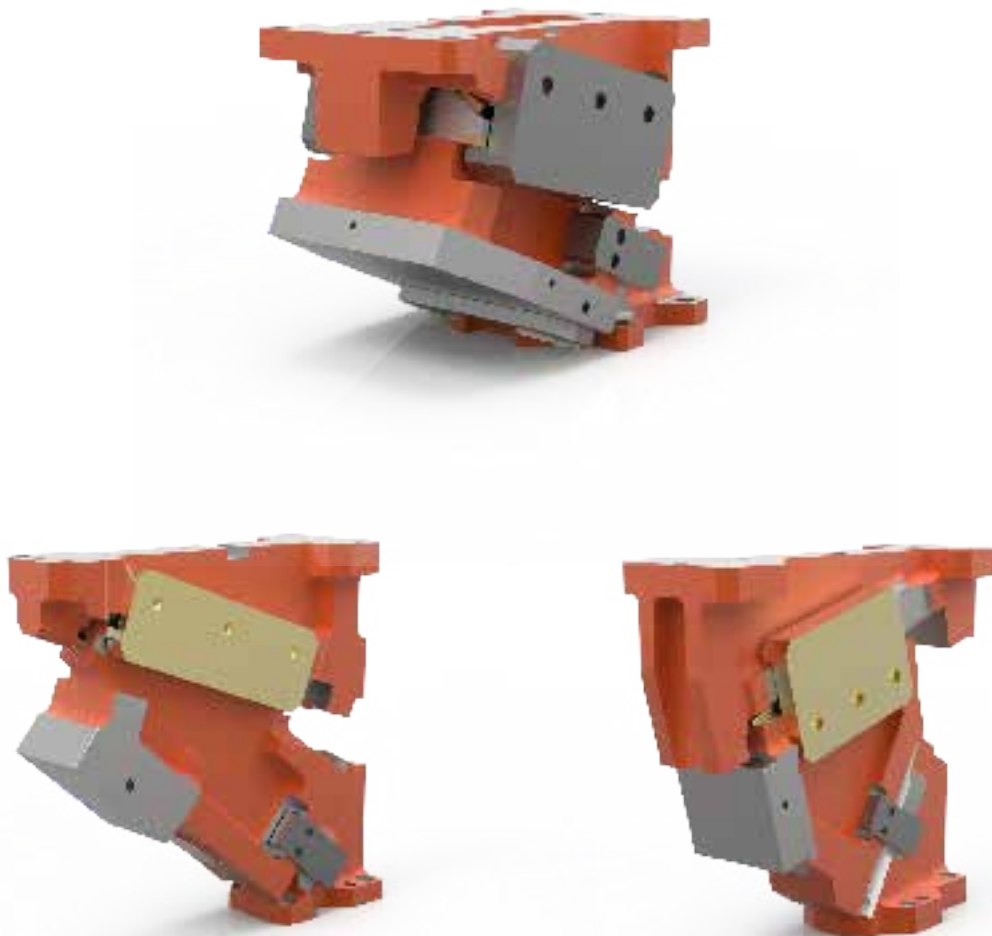

Figure 32: Selection of various customer-specific cam units

INTRODUCTION AND TABLE OF CONTENTS

ENGINEERING

2016.24. AERIAL FCC BAK

DAIMLER, VOLVO,
VOLKSWAGEN GROUP

2016.25. AERIAL FCC BAK

DAIMLER, VOLVO,
VOLKSWAGEN GROUP

2016.207. AERIAL ECO LINE

2016.208. AERIAL ECO LINE

CUSTOMER-SPECIFIC SERVICES

APPENDIX

EMERGENCY SITUATION / CONTACTS

APPENDIX

OVERVIEW

Table of contents, “Appendix” chapter

Overview	307
Lubrication instructions	308
CAD colour coding for machining according to OEM standard	309
Sheet metal materials in vehicle construction	310
Dictionary, English – German	314

APPENDIX

LUBRICATION INSTRUCTIONS

Always prevent the slider and driver surface from running dry, even during the breaking-in of the tools.
An initial lubrication is necessary.

Note: VDI 3378, Observe lubrication of large stamping dies

Recommended: Lithium saponified greases without MoS₂ and graphite additives, e.g.:

DEA:	PARAGON EP1
ESSO:	EXXON multi-purpose grease
MOBIL:	LicAl ÖL 8561
AVIA:	Multi-purpose grease
Fuchs:	Renolin ZAF 46 MB Öl

APPENDIX

CAD COLOUR CODING FOR MACHINING ACCORDING TO OEM STANDARD

Machining type	Comment	CATIA V5 RGB values			
		Colour	Red	Green	Blue
Areas dependent to method plan	All machining which is not performed according to solid model, but according to separate data record	Olive green	175	255	175
Smoothing/ finishing	Fine machining (for further details, see work instructions)	Pink	255	175	175
Roughing	Rough machining	Red-brown	095	000	000
Fitting bore H11	Also special milling processing	Blue	095	095	175
Fitting bore H8	Also special milling processing	Purple	095	000	095
Fitting bore H7	Also special milling processing	Blue	000	000	255
Fitting bore H6	Also special milling processing	Dark blue	000	095	175
Threads	Metric right thread according to DIN/ISO	yellow	255	255	000
Fine threads	Metric fine thread (right) according to DIN/ISO	Orange	255	175	000
Spiral lock / special thread	All other special threads	Orange	255	095	000
Special bore / stepped bore	Complex bores, combination of bores	Magenta	255	000	255
Free bore / simple bore	Through holes, etc., other countersinks	Cyan	000	175	175
Change areas	Sphere or Solid with transparency 192	Light blue	000	127	255
Assembly bores	Assembly features	White	255	255	255

APPENDIX

SHEET METAL MATERIALS IN VEHICLE CONSTRUCTION

Standard designation	Other Designations	Trade names	Standard	Rm [N/mm ²]
Deep drawing steels, cold-rolled				
DC01	St12 / FeP01		EN 10130	270..410
DC03	RRSt13		EN 10130	270..370
DC04	St14 / FeP04		EN 10130	270..350
DC05			EN 10130	270..330
DC06	IF18		EN 10130	270..330
DC07			EN 10130	250..310
DC01+ZE	St12 / FeP01		EN 10152	270..410
DC03+ZE	RRSt13		EN 10152	270..370
DC04+ZE	St14 / FeP04		EN 10152	270..350
DC05+ZE			EN 10152	270..330
DC06+ZE	IF18		EN 10152	270..350
DC07+ZE			EN 10152	250..310
DX51D+Z			EN 10346	270..500
DX52D+Z			EN 10346	270..420
DX53D+Z			EN 10346	270..380
DX54D+Z			EN 10346	260..350
DX56D+Z			EN 10346	260..350
Deep drawing steels, hot-rolled				
DD11		alform 200 N	EN 10111	max. 440
DD12		alform 200 N	EN 10111	max. 420
DD13		alform 180 N	EN 10111	max. 400
DD14		alform 180 N	EN 10111	max. 380
high-strength phosphor-alloyed steels, cold-rolled				
HC180P	EN 10268	280..360		
HC220P /+ZE	H220P /+ZE	Z StE 220P /+ZE	EN 10268	320..400
HC260P /+ZE	H260P /+ZE	Z StE 260P /+ZE	EN 10268	360..440
HC300P /+ZE	H300P /+ZE	Z StE 300P /+ZE	EN 10268	400..480
HC220PD+Z	H220PD+Z	Z StE 220P+Z	EN 10292	320..400
HC260PD+Z	H260PD+Z	Z StE 260P+Z	EN 10292	370..450
HC300PD+Z	H300PD+Z	Z StE 300P+Z	EN 10292	400..480
high-strength bake-hardening steels, cold-rolled				
HC180B /+ZE	H180B+ZE	Z StE 180 BH+ZE	EN 10268	300..360
HC220B /+ZE	H220B+ZE	Z StE 220 BH+ZE	EN 10268	320..400
HC260B /+ZE	H260B+ZE	Z StE 260 BH+ZE	EN 10268	360..440
HC300B /+ZE	H300B+ZE	Z StE 300 BH+ZE	EN 10268	400..480
HC180BD+Z	H180BD+Z	Z StE 180 BH+Z	EN 10292	300..360
HC220BD+Z	H220BD+Z	Z StE 220 BH+Z	EN 10292	340..400
HC260BD+Z	H260BD+Z	Z StE 260 BH+Z	EN 10292	360..440
HC300BD+Z	H300BD+Z	Z StE 300 BH+Z	EN 10292	400..480

Information provided without guarantee

APPENDIX

SHEET METAL MATERIALS IN VEHICLE CONSTRUCTION

Standard designation	Other Designations	Trade names	Standard	Rm [N/mm ²]
higher strength bake-hardening steels (rolling condition not specified)				
HX180BD+Z			EN 10268	290..360
HX220BD+Z			EN 10268	320..400
HX260BD+Z			EN 10268	360..440
HX300BD+Z			EN 10268	400..480
higher isotropic steels, cold-rolled				
HC220I /+ZE	Z StE 220 I /+ZE	HIZ 220 /ZE	EN 10268	300..380
HC260I /+ZE	Z StE 250 I /+ZE	HIZ 260 /ZE	EN 10268	320..400
HC280I /+ZE	Z StE 280 I /+ZE	HIZ 300 /ZE	EN 10268	340..440
HC300I			EN 10268	340..440
HC220ID+Z	Z StE 220 I+Z	HIZ 220+Z	EN 10268	300..380
HC260ID+Z	Z StE 250 I+Z	HIZ 260+Z	EN 10268	300..380
HC280ID+Z	Z StE 280 I+Z	HIZ 300+Z	EN 10268	340..440
higher-strength IF steels, cold-rolled				
HC160Y /+ZE			EN 10268	340..400
HC180Y /+ZE	H180Y /+ZE		EN 10268	340..400
HC220Y /+ZE	H220Y /+ZE		EN 10268	350..420
HC260Y /+ZE	H260Y /+ZE		EN 10268	380..440
HC160YD+Z	H160YD+Z		EN 10292	340..400
HC180YD+Z	H180YD+Z		EN 10292	340..400
HC220YD+Z	H220YD+Z		EN 10292	370..410
HC260YD+Z	H260YD+Z		EN 10292	380..440
higher strength IF steels (rolling condition not specified)				
HX160YD+Z			EN 10268	300..360
HX180YD+Z			EN 10268	330..390
HX220YD+Z			EN 10268	340..420
HX260YD+Z			EN 10268	380..440
HX300YD+Z			EN 10268	390..470
high-strength, micro-alloyed steels, cold-rolled				
HC260LA /+ZE	H260LA /+ZE	Z StE 260/+ZE	EN 10268	350..450
HC300LA /+ZE	H300LA /+ZE	Z StE 300/+ZE	EN 10268	380..480
HC340LA /+ZE	H340LA /+ZE	Z StE 340/+ZE	EN 10268	410..510
HC380LA /+ZE	H380LA /+ZE	Z StE 380/+ZE	EN 10268	440..560
HC420LA /+ZE	H420LA /+ZE	Z StE 420/+ZE	EN 10268	470..590
HC460LA /+ZE			EN 10268	500..640
HC500LA /+ZE			EN 10268	530..690

Information provided without guarantee

APPENDIX

SHEET METAL MATERIALS IN VEHICLE CONSTRUCTION

Standard designation	Other Designations	Trade names	Standard	Rm [N/mm ²]
higher-strength, micro-alloyed steels (rolling condition not specified)				
HX260LAD+Z			DIN EN 10346	350..430
HX300LAD+Z			DIN EN 10346	380..480
HX340LAD+Z			DIN EN 10346	410..510
HX380LAD+Z			DIN EN 10346	440..560
HX420LAD+Z			DIN EN 10346	470..590
HX460LAD+Z			DIN EN 10346	500..640
HX500LAD+Z			DIN EN 10346	530..690
higher-strength dual-phase steels, cold-rolled				
	H260X /+ZE /+Z	DP 450	prEN 10338	>450
	H270X /+ZE /+Z	DP-K 27/50	prEN 10338	>500
	H310X /+ZE /+Z	DP-K 31/60	prEN 10338	>600
	H380X /+ZE /+Z	DP-K 38/60	prEN 10338	>600
HCT450X+ZE			prEN 10338	>450
HCT500X /+ZE /+Z	H300X /+ZE /+Z	DP-K 30/50	prEN 10338	>500
HCT600X /+ZE /+Z	H340X /+ZE /+Z	DP-K 34/50	prEN 10338	>600
higher-strength dual-phase steels, cold-rolled				
HCT780X /+ZE /+Z			prEN 10338	>780
higher-strength dual-phase steels, hot-rolled				
HDT580X	DD33X /+ZE /+Z	DP600	prEN 10338	580..670
Complex phase steels, cold-rolled				
HCT600C			prEN 10338	>600
HCT780C+ZE /+Z			prEN 10338	>780
HCT980C+ZE /+Z			prEN 10338	>980
Complex phase steels, hot-rolled				
HDT780C	D680C /+ZE /+Z	CP800	prEN 10338	780
	D680C /+ZE /+Z	CP900	prEN 10338	>880
	D720C /+ZE /+Z		prEN 10338	950..1130
Ferrite-bainite phase steels, hot-rolled				
HDT450F			prEN 10338	450
HDT560F			prEN 10338	560

Information provided without guarantee

APPENDIX

SHEET METAL MATERIALS IN VEHICLE CONSTRUCTION

Standard designation	Other Designations	Trade names	Standard	Rm [N/mm ²]
TRIP steels (Transition Included Plasticity), cold-rolled				
H380T /+ZE /+Z	RA-K 38/60		WSDB 18	>600
H400T /+ZE /+Z	RA-K 40/70	TRIP 700	WSDB 18	>700
H420T /+ZE /+Z	RA-K 42/80	TRIP 800	WSDB 18	>800
HC600T /+ZE /+Z			prEN 10338	>600
HCT690T+ZE			prEN 10338	>690
HCT780T+ZE			prEN 10338	>780
Martensitic steels, hot-rolled				
	D750MS /+ZE		not standardised	1000..1200
HDT1200M	D900MS /+ZE	MS-W 1200	prEN 10338	1200..1400
	D1050MS /+ZE		not standardised	1350..1550
	D750MS /+Z		not standardised	1000..1200
	D900MS /+Z	MS1200	not standardised	1200..1400
high-strength micro-alloyed steels, hot-rolled				
S315MC /+ZE /+Z		alform 315 M	DIN EN 10149-2	390..510
S355MC /+ZE /+Z		alform 355 M	DIN EN 10149-2	430..550
S420MC /+ZE /+Z		alform 420 M	DIN EN 10149-2	480..620
S460MC /+ZE /+Z		alform 460 M	DIN EN 10149-2	520..670
S500MC /+ZE /+Z		alform 500 M	DIN EN 10149-2	550..700
S550MC /+ZE /+Z		alform 500 M	DIN EN 10149-2	600..760
S600MC /+ZE /+Z		alform 600 M	DIN EN 10149-2	650..820
S650MC /+ZE /+Z		alform 650 M	DIN EN 10149-2	700..880
S700MC /+ZE /+Z		alform 700 M	DIN EN 10149-2	750..930
Hardening and heat treatable/ tempering steels, cold-rolled, unalloyed				
15+LC		C15E	DIN EN 10084	<475
C35+LC		C35E	DIN EN 10084	<550
C45+LC		C45E	DIN EN 10084	<595
C60+LC		C60E	DIN EN 10084	<650

Information provided without guarantee

APPENDIX

DICTIONARY, ENGLISH – GERMAN

A

accuracy of measurement	Maßgenauigkeit
aerial cam	oben hängender Schieber
alloyed	legiert
attachment lug, clamp	Klammer

B

back-up	Schulter
back-up thrusted	Schulterung
beam / transport beam / side bar	Greiferbalken
bend (to ...)	biegen
blank	Platine
blank die	Platinenschneidwerkzeug
blank holder	Blechhalter
blank thickness	Blechdicke
blanking pressure	Presskraft
blanking pressure / trim force	Schneidkraft
border hardening	randhärten
brass	Messing
bronze with non-liquid lubricant	Bronze mit Festschmierstoff
buck	Aufsatz
burr	Schnittgrat
bush	Buchse
button	Schneidbuchse

C

cam base	Schieberbett
cam base angle	Schieberbettwinkel
cam diagram	Schieber-(ablauf-)diagramm
cam driver	Treiber
cam lock out	Schieberverriegelung
cam slide pad	Schieberniederhalter
cam slide return	Schieberrückholung
cam slide stop / cam buffer	Schieberanschlag
cam slide unit / wedge drive	Keilschieber
cam slider / slide	Schieberteile
cam stroke	Schieberhub
cam stroke plate	Überlaufkeil
cam width	Schieberbreite
cam, wedge drive	Schieber

APPENDIX

DICTIONARY, ENGLISH – GERMAN

carburize (to ...)	einsatzhärten
cast	Guss
center of force	Kraftschwerpunkt
center of gravity	Schwerpunkt
change index	Änderungsindex
clamping gripper	Klemmgreifer
clamping surface, lower	Aufspannfläche unten
clamping surface, upper	Aufspannfläche oben
clearance	Führungsspiel
clinch (to ...)	bördeln
coat (to ...)	beschichten
coil spring	Spiralfeder
common level	gemeinsame Ebene
core	Kern
crossbar	Saugerbalken
crossbar transfer press	Saugerbalkentransferpresse
cutting clearance	Schneidspalt

D

damper / damping element / shock absorber	Dämpfer
diagonal measurement	Diagonalmaß
die	Matrize
die acceptance	Werkzeugabnahme
die closed	Werkzeug geschlossen
die diagram	Werkzeugablaufdiagramm
die mount cam	unten laufender Schieber
die, tool	Werkzeug
dowel	Stift
dowel	Zylinderstift
dowel hole	Stiftloch
draw (to ...)	ziehen
draw die	Ziehwerkzeug
drill (to ...)	bohren
drill (to ...)	drehen
driver angle	Treiberwinkel

E

execution	Ausführung
-----------	------------

APPENDIX

DICTIONARY, ENGLISH – GERMAN

F

feather key	Passfeder
filler cam	Füllschieber
fit (to ...)	passen
flange up	hochstellen
flash, burr	Grat
floater	Luftboden
flowchart	Ablaufdiagramm
force	Kraft
force diagram	Lastdiagramm
form buck	Formaufsatz
form die	Formwerkzeug
full assembled	vollbestückt

G

gas spring	Gasdruckfeder
general information	Beschreibung
grey cast iron	Grauguss
grind (to ...)	schleifen
gripper	Greifer
guide bearing	Führungslager
guide block	Führungsaufnahme
guide bush	Führungsbuchse
guide pin	Führungssäule
guide plate / wear plate	Führungsplatte
guide roller	Führungsrolle
guide strip	Führungsleiste
guiding element / sliding element	Führungselement

H

harden (to ...)	härten
hardened	gehärtet
high alloyed	hochlegiert
high wear	hochbeansprucht
horizontal force	Horizontalkraft n

I

identification plate	Kennzeichenschild
impact plate	Anschlagplatte
included angle	eingeschlossener Winkel

APPENDIX

DICTIONARY, ENGLISH – GERMAN

included angle	Schieberteilwinkel
induction harden	induktionshärten
interference curve	Freigängigkeitskurve
item number	Position

K

key, wedge	Keil
keyway	Keilsitz

L

label	Schild
length	Länge
length of trim line	Beschnittlänge
light duty	leichte Ausführung
lock out	Lock out
lock out	Verriegelung
lock out plate	Lock out Platte
lock out tube	Lock out Hülse
lock out tube	Verriegelungshülse
lower die	Gussunterteil
lower die	Unterteil
lower die	Werkzeugunterteil
lubricant insert	Festschmierstoff
lubrication	Schmierung

M

machine (to ...)	bearbeiten
machining	Bearbeitung
maintenance	Instandhaltung
mill (to ...)	fräsen
mount (to ...)	montieren
mounting surface	Montagefläche
mounting surface, bottom	Aufspannplatte unten
mounting surface, top	Aufspannplatte oben

N

nodular graphite iron	Sphäroguss
normalize	glühen

APPENDIX

DICTIONARY, ENGLISH – GERMAN

O

order code / order no. Bestell-Nummer

P

pad	Niederhalter
pad travel	Niederhalterweg
pattern	Gießmodell
pattern release	Modellfreigabe
pierce (to ...)	lochen
pierce die	Lochwerkzeug
piercing bush, button	Lochbuchse
pillar, guide pin	Säule
pin, bolt	Bolzen
positiv locking	Formschluss
positive return	Zwangsrückholer, Zwangsrückzug
pre-acceleration	Vorbeschleunigung
pre-acceleration angle	Vorbeschleunigungswinkel
pre-acceleration stroke	Vorbeschleunigungshub
press fit	Presspassung
press stroke	Pressenhub
press tonnage	Pressen-Nennkraft
prism	Prisma
progressive die	Folge-(verbund-) werkzeug
protrusion	Überhang
punch	Lochstempel
punch	Schneidstempel
punch	Stempel
punch	Ziehstempel
punch retainer	Stempelhalteplatte
punch stripper	Stempelabstreifer
punching force	Kraft für Lochen
punching tool / trim die	Schneidwerkzeug

R

reference point	Bezugspunkt
release	Zeichnungsfreigabe
release (to ...)	freigeben
restrike (to ...)	nachschlagen
restrike steel	Nachschlagbacken
retraction force	Rückzugskraft

APPENDIX

DICTIONARY, ENGLISH – GERMAN

return	Rückstellung
return force	Rückstellkraft
rework, modify (to ...)	nacharbeiten
rubber spring	Gummifeder
S	
scrap	Schrott
scrap chute	Abfallrutsche
shaft screw	Passschraube
sharp edges removed	Kante gebrochen
shear strength	Scherfestigkeit
shock absorber / damping element	Stoßdämpfer
shut height	Bauhöhe
shut height	Einbauhöhe
sidebar transfer press	Greifertransferpresse
slide	Gleitfläche
slide direction	Gleitrichtung
slide fit	Gleitsitz
slide plane	Gleitebenen
sliding pad / wear plate	Gleitplatte
slug	Lochbutzen
spare part	Ersatzteil
spare part list	Ersatzteilliste
spark, wire cut (to ...)	erodieren
spot (to ...)	tuschieren
spotting press	Tuschierpresse
spring	Feder
spring force	Federkraft
spring stroke	Federhub
steel hardened	Stahl gehärtet
stick	klemmen
stock list	Stückliste
strip layout	Streifenbild
stripper	Abstreifer
stripper force	Abstreifkraft
stroke	Hub
suction cup	Sauger

APPENDIX

DICTIONARY, ENGLISH – GERMAN

T

take thrust out (to ...)	Schub abfangen
tapped hole	Gewindebohrung
tensile strenght	Zugfestigkeit
term	Bezeichnung
thrust	Schub
tight fit	Presssitz
time	Zeit
tool steel	Werkzeugstahl
torque	Drehmoment
towing hole	Transportgewinde
transfer press	Stufenpresse
trim (to ...)	beschneiden
trim buck	Schneidaufsatz
trim die	Beschneidewerkzeug
trim line	Beschneidekante
trim steel	Messer
trim steel	Schneidmesser
type	Bauart

U

upper die	Gussoberteil
upper die	Oberteil
upper die	Werkzeugoberteil
urethan spring	Kunststofffeder
urethan stripper	Kunststoffabstreifer

V

vertical force	Vertikalkraft
v-guide	Prismaführung

W

wear	Verschleiß
weld (to ...)	schweißen
working angle / cam	Schieber-(arbeits-)winkel
working area / mounting surface	Schieberarbeitsfläche
working force	Arbeitskraft
working force	Betriebslast
working stroke / cam stroke	Schieber-(arbeits-)hub

INTRODUCTION AND TABLE OF CONTENTS

ENGINEERING

2016.24. AERIAL FCC BAK

DAIMLER, VOLVO,
VOLKSWAGEN GROUP

2016.25. AERIAL FCC BAK

DAIMLER, VOLVO,
VOLKSWAGEN GROUP

2016.207. AERIAL ECO LINE

2016.208. AERIAL ECO LINE

CUSTOMER-SPECIFIC SERVICES

APPENDIX

**EMERGENCY SITUATION /
CONTACTS**



EMERGENCY SITUATION / CONTACTS

FIBRO cam units are marked with a unique, unmistakable serial number.

Since October 2017, these serial numbers, together with all other important names, are grouped together on a type plate (see fig.).

Until September 2017 the serial numbers were engraved directly on the cam units.

The type plate is located on the side of your cam unit.



Legend:

Art. No:	article number	(order number)
Std:	Standard	(standard)
W/A:	width/angle	(width/angle)
Serial:	serial number	(serial number)
Pos:	position	(Position)
GS:	gas spring	(gas spring)
GS:	gas spring	(gas spring)

In order to help you as quickly as possible, we require both the article number and the unique serial number when ordering individual spare parts as well as when replacing a complete cam unit in case of a crash.

In these cases, please always include the serial number for a quick handling of your needs.



If an acute emergency occurs, for example, in the form of a tool crash, we are there for you. In the event of a crash, you can reach us as follows:

via phone: +49 (6266) 73-112

via email: cam.crash@fibro.de

EMERGENCY SITUATION / CONTACTS



FIBRO offers you a comprehensive service in the field of cam units to help you with advice and action if necessary.

- Spare parts deliveries ex stock
- The fastest possible delivery of replacement cam units in the event of a crash
- Construction support

If you have any questions concerning our cam unit program, please contact:

Markus Meyer
Head of Cam Unit Applications
cam.engineering@fibro.de
+49 (6266) 73-210

Georg Schreck
Product Manager Cam Unit Applications
cam.engineering@fibro.de
+49 (6266) 73-210

Markus Steinhilber
Key Account Manager Cam Unit Applications
m.steinhilber@fibro.de
+49 (151) 64975857

EMERGENCY SITUATION / CONTACTS

For offers and price information, please contact your regional supply centre:

Germany	Postal code region 1... – 6...	ac1.normalien@fibro.de
	Postal code region 7... – 0...	ac2.normalien@fibro.de
International	Eastern Europe, Africa, Asia	ac3.normalien@fibro.de
	Western Europe, North and South America	ac4.normalien@fibro.de

For orders, date information and general service questions, please contact your local sales centre:

Germany	Postal code region 1... – 6...	vc1.normalien@fibro.de
	Postal code region 7... – 0...	vc2.normalien@fibro.de
International	Eastern Europe, Africa, Asia	vc3.normalien@fibro.de
	Western Europe, North and South America, Australia	vc4.normalien@fibro.de

... or contact your on-site partner, please see pages 4-7.



FIBRO GMBH

MEMBER OF THE L'APPLE GROUP

Business Area Standard Parts

August-Läpple-Weg

74855 Hassmersheim

T +49 6266 73-0

F +49 6266 73 237

info@fibro.de

Order No. 2.2914.01.0618.0100000